

SONY[®]

4-438-654-12(1)

Interchangeable Lens
Digital Camera

***α*99**

***α* Handbook**

A-mount

α

Table of contents

Introduction of functions	9
---------------------------------	---

Before use

Notes on using your camera	12
Checking the supplied items	15
Identifying parts	16
Front side	16
Rear side	17
Top side	19
Sides	21
Bottom	23
Shoe adaptor	24
List of icons on the screen	25
List of icons on the LCD screen	25
List of icons on the display panel	29

Functions list

Functions that can be operated with the buttons/dial	30
How to use the Quick Navi screen	31
How to use the silent multi-controller	32
Selecting a function with the Fn (Function) button	34
Functions that can be selected with the Fn (Function) button	35
The functions selected with the MENU button	37
Using the In-Camera Guide	48

Preparing the camera



Charging the battery pack	49
Inserting the battery pack/memory card (sold separately)	51
Compatible memory cards	54
Attaching a lens	55
Setting the date and time	57
Setting up the date/time again	58
Adjusting the angle of the LCD screen	59
Shooting a clear image without camera shake	60
Camera shake warning indicator	60

Using the SteadyShot function	60
Holding the camera properly	61
Removing the Eyepiece cup	62

Shooting and viewing images

Shooting still images	63
Recording movies	65
Playing back images	66
Switching between still images and movies	66
Deleting images	67

Selecting a shooting mode

Selecting a shooting mode	68
Selecting the desired mode by rotating the mode dial	69
AUTO Auto Mode	69
SCN Scene Selection	71
 Sweep Panorama	73
T  Tele-zoom Cont. Priority AE	76
P Program Auto	77
A Aperture Priority	78
S Shutter Priority	80
M Manual Exposure	82
M BULB	84
Functions available for each shooting mode	86

Switching the recording information display

Switching the recording information display (DISP)	87
Selecting the screen mode	87
Histogram	89
Monitoring the subject through the lens without effects displayed	89

Adjusting the focus



Adjusting the focus	91
Autofocus	91
Focus-lock	94
AF area	95
Object Tracking	95
Restricting the autofocus range (AF Range Control)	98

Adjusting the focus except for the shutter button (AF On)	100
AF illuminator	100
AF Micro Adj.	101
Manual focus	101
Enhancing the outline of in-focus ranges (Peaking)	102
Focus Magnifier	103
Direct manual focus (DMF)	104
AF/MF control	105

Adjusting the brightness of the image

Exposure compensation	106
AE Lock	108
Metering Mode	109

Using the drive mode

 /  Selecting the drive mode	110
Shooting single shot	110
Cont. Shooting	111
Self-timer	111
Bracket: Cont./Single Bracket	112
WB bracket	113
DRO Bracket	114
Remote Cdr.	114

Advanced shooting

Using the flash (sold separately)	115
Wireless flash	116
Slow Sync	117
Using a flash equipped with a flash sync terminal cord	118
Flash modes available	119
Flash Compensation	120
Flash control	121
FEL lock	122
Setting ISO	124
Multi frame noise reduction	124
Compensating for the brightness and contrast automatically (D-Range)	126

D-RangeOptimizer	126
Auto HDR	127
Setting the image processing	129
Picture Effect	129
Creative Style	130
Adjusting the color tones (White balance)	133
C.Temp./Filter	134
Custom white balance	135
Setting image size	137
Image Size	137
Panorama: Size	137
Setting the aspect ratio and image quality	139
Aspect Ratio	139
Quality	139
Detecting faces	141
Face Registration	142
Auto Port. Framing	143
Smile Shutter	145
Zooming	147
Zooming in in one step (Smart teleconverter)	147
Zooming in holding the current resolution of the image (Clear Image Zoom)	147
Reducing the noise in an image	150
Long Exposure NR	150
High ISO NR	150
Setting the color space	151

Movie recording setup

Movie recording setup	152
Changing the tracking sensitivity of autofocus during movie recording	153
Recording movies with the shutter speed and aperture adjusted	153
File Format	155
Record Setting	155
Audio Rec Level	157
Audio Level Display	157
Checking the audio using headphones	158
Audio Output Timing	158

Audio Recording	159
-----------------------	-----

Advanced playback

Using the playback functions	160
Selecting the memory card used to be played back	160
Switching between still images and movies (View Mode)	160
Enlarging images	160
Switching to the display of the image list	161
Rotating an image	162
Slide Show	163
Playback Display	164
The screen displayed for playback mode	165
Switching the screen during playback	165
List of icons on the histogram display	165
Protecting images (Protect)	167
Specifying printing	168
Specifying DPOF	168
Date Imprint	168
Copying images	169
Deleting images (Delete)	170
Delete (Multiple Img.)	170
Deleting all images or movies visible in the current view mode.....	171
Viewing images on a TV screen	172
HDMI Info. Display	173
Using “BRAVIA” Sync	174

Setup of the camera

Setting the other functions of the camera	175
Release w/o Lens	175
Grid Line	175
Auto Review	175
Func. of AEL button	176
ISO Button, AF/MF button, Preview Button	176
Custom button	177
Electronic Front Curtain Shutter	177
LCD Brightness	177
Viewfinder Bright.	178

Power Save	178
FINDER/LCD Setting	179
APS-C Size Capture	179
PAL/NTSC Selector (only for the 1080 50i-compatible device)	180
Lens compensation	181
Lens Comp.: Peripheral Shading	181
Lens Comp.: Chromatic Aberration	181
Lens Comp.: Distortion	181
Setting the method for recording on a memory card	182
Recording Mode	182
Format	183
File Number	183
Folder Name	183
Select REC Folder	184
New Folder	184
Recover Image DB	185
Upload Settings	185
Recording location information using the GPS feature	
(SLT-A99V only)	187
GPS Assist Data	188
GPS Auto Time Cor.	188
Registering your own settings	190
Resetting to the default	191
Confirming the software version	198

Viewing images on a computer

Using the software	199
Using “Image Data Converter”	199
Using “PlayMemories Home”	199
Using “Remote Camera Control”	200
Recommended computer environment (Windows)	
.....	201
Recommended computer environment (Mac)	201
Installing the software (Windows)	202
Installing the software (Mac)	203
Connecting the camera to the computer	204
Setting the USB connection	204

Setting the LUN (Logical Unit Number) (USB LUN Setting)	204
Connecting to the computer	205
Importing images to the computer (Windows)	205
Importing images to the computer (Mac)	206
Disconnecting the camera from the computer	207
Creating a movie disc	208
Selecting the method for creating a disc of movies	208
Creating a high definition image quality (HD) disc (AVCHD recording disc)	209
Creating a standard definition image quality (STD) disc	210
Discs you can use with “PlayMemories Home”	211
Creating a disc with a device other than a computer	211

Troubleshooting/Others

Troubleshooting	212
Warning messages	221
Cleaning the camera and a lens	223
Cleaning the image sensor	224
Precautions	227
To use your camera abroad — Power sources	230
AVCHD format	231
GPS (SLT-A99V only)	232
Memory card	234
Battery pack/Battery charger	236
The License	238

Index	239
--------------------	------------

Introduction of functions

This section introduces some frequently-used shooting functions and characteristic functions.

See the pages in parentheses for details.

Shooting functions used frequently

Exposure compensation (106)

You can compensate the exposure to adjust the brightness of the entire screen.

Even when the exposure mode is set to M, the exposure can be compensated if the ISO sensitivity is set to [AUTO].

ISO sensitivity (124)/Multi frame noise reduction (124)

You can set the sensitivity to light.

The ISO sensitivity can be adjusted between ISO 50 and ISO 25600.

When you select $\frac{ISO}{AUTO}$ (Multi Frame Noise Reduct.), you can select larger ISO numbers than the maximum ISO sensitivity.

White balance (133)

You can adjust the color tones.

You can select an option to suit a light source, or perform a fine adjustment by combining the color temperature with the color filter.

Drive mode (110)

You can use an appropriate drive mode to suit your purposes, such as single-shot advanced, continuous advanced, bracket, or shooting with a Wireless Remote Commander.

Original characteristic functions

AF Range Control (98)

You can restrict the autofocus range to prevent unintended subjects from being focused on.

DRO/Auto HDR (126)

D-Range Optimizer: By dividing the image into small areas, the camera analyses the contrast of light and shadow between the subject and the background, producing the image with the optimal brightness and gradation.

Auto HDR: Shoots 3 images with different exposures, and then overlays these images to create an image with rich gradation.

Creative Style (130)

You can select the desired style from among 13 styles.

You can also adjust certain factors of the images, such as the exposure, by using the selected style as the base.

Hand-held Twilight (72)

You can shoot night scenes with less noise and blur without using a tripod.

Movie recording with manual adjustments (153)

You can adjust the exposure in P, A, S, M mode during movie recording.

How to operate or customize the camera

Screen information (87)

When you look into the viewfinder, the viewfinder mode is activated, and when you take your face away from the viewfinder, the viewing mode returns to the LCD screen mode. You can change the screen mode by pressing the DISP button.

Quick Navi (31)

In viewfinder mode, you can quickly switch the LCD screen to the Quick Navi screen by pressing the Fn button. You can set the items with an intuitive operation.

Silent multi-controller (32)

Using the silent multi-controller that is designed to reduce the sound of dial rotation, you can set certain items silently, such as focus mode, or recording level.

Customization (42, 177)

The camera is equipped with a custom button that can be assigned a desired function. You can also assign functions to other buttons, such as the AEL button, or the ISO button.

Notes on using your camera

Screen language

You can select the language displayed on the screen using the menu (page 47).

Shooting procedure

This camera has 2 modes for monitoring subjects: the LCD screen mode using the LCD screen, and the viewfinder mode using the viewfinder.

Notes on the functions available with the camera

- To check whether it is a 1080 60i-compatible device or 1080 50i-compatible device, check for the following marks on the bottom of the camera.
1080 60i-compatible device:60i
1080 50i-compatible device:50i
- This camera is compatible with 1080 60p or 50p-format movies. Unlike standard recording modes up to now, which record in an interlacing method, this camera records using a progressive method. This increases the resolution, and provides a smoother, more realistic image.

Shooting with a DT lens

This camera is equipped with a 35 mm, full-frame CMOS sensor, however, the image size is automatically set to that of the APS-C size setting, and the image size is smaller when a DT lens ("DT" is attached to the product name) is used (page 137).

No compensation for contents of the recording

The contents of the recording cannot be compensated for if recording or playback is not possible due to a malfunction of your camera or a memory card, etc.

Back up recommendation

To avoid the potential risk of data loss, always copy (back up) data to other medium.

Notes on the LCD screen, electronic viewfinder, lens, and image sensor

- The LCD screen and electronic viewfinder are manufactured using extremely high-precision technology so over 99.99% of the pixels are operational for effective use. However, there may be some tiny black points and/or bright points (white, red, blue or green in color) that constantly appear on the LCD screen and electronic viewfinder. These points are normal in the manufacturing process and do not affect the images in any way.
- Do not hold the camera by the LCD screen.
- Do not expose the camera to sunlight or shoot sunward for a long time. The internal mechanism may be damaged. If sunlight is focused on a nearby object, it may cause a fire.
- There is a magnet on the back and around the rotating shaft of the hinge part of the LCD screen. Do not bring anything that is easily affected by a magnet, such as floppy disks or credit cards, near the LCD screen.
- Images may trail across on the screen in a cold location. This is not a malfunction. When turning on the camera in a cold location, the screen may become temporarily dark. When the camera warms up, the screen will function normally.
- The recorded image may be different from the image you monitored before recording.

Notes on long-time recording

- When you continue to shoot for a long time, the temperature of the camera rises. If the temperature reaches above a certain level, the [] icon appears on the screen and the camera turns itself off automatically. If the power is turned off, leave the camera for 10 minutes or longer to allow the temperature inside the camera to decrease to a safe level.
- Under high ambient temperatures, the temperature of the camera rises quickly.

- When the temperature of the camera rises, the image quality may deteriorate. It is recommended that you wait until the temperature of the camera drops before continuing to shoot.
- The surface of the camera may get warm. This is not a malfunction.

Notes on importing AVCHD movies to a computer

When importing AVCHD movies to a computer, for Windows computers, use the “PlayMemories Home” software on the CD-ROM (supplied).

Notes when playing movies on other devices

- This camera uses MPEG-4 AVC/H.264 High Profile for AVCHD format recording. Movies recorded in AVCHD format with this camera cannot be played with the following devices.
 - Other devices compatible with AVCHD format that does not support High Profile
 - Devices incompatible with the AVCHD format

This camera also uses MPEG-4 AVC/H.264 Main Profile for MP4 format recording. For this reason, movies recorded in MP4 format with this camera cannot be played on devices other than those that support MPEG-4 AVC/H.264.

- Discs recorded with HD image quality (high definition) can be played back only on AVCHD format-compatible devices. DVD-based players or recorders cannot play back HD image quality discs, as they are incompatible with the AVCHD format. Also, DVD-based players or recorders may fail to eject HD image quality discs.
- 1080 60p/50p movies can be played back on compatible devices only.

On GPS-compatible devices (SLT-A99V only)

- To determine whether your camera supports GPS function, check the model name of your camera.
GPS-compatible: SLT-A99V
GPS-incompatible: SLT-A99
- Use GPS in accordance with regulations of countries and regions where you use it.
- If you do not record the location information, set [GPS On/Off] to [Off] (page 187).
- In an airplane, make sure to turn off the camera following cabin announcements.

Warning on copyright

Television programs, films, videotapes, and other materials may be copyrighted. Unauthorized recording of such materials may be contrary to the provisions of the copyright laws.

The pictures used in this manual

The photographs used as examples of pictures in this manual are reproduced images, and are not actual images shot using this camera.

On the data specifications described in this manual

The data on performance and specifications is defined under the following conditions, except as described in this manual: at an ordinary ambient temperature of 25°C (77°F), and using a battery pack that has been fully charged for about 1 hour after the CHARGE lamp has turned off.

Notes on shooting with the viewfinder

This camera is equipped with an XGA Organic Electro-Luminescence viewfinder with high resolution and high contrast. This viewfinder achieves a wide viewing angle and a long eye relief. This camera is designed to provide an easily viewable viewfinder by appropriately balancing various elements.

- The image may be slightly distorted near the corners of the viewfinder. This is not a malfunction. When you want to check

every detail of the entire composition, you can also use the LCD screen.

- If you pan the camera while looking into the viewfinder or move your eyes around, the image in the viewfinder may be distorted or the color of the image may change. This is a characteristic of the lens or display device and is not a malfunction. When you shoot an image, we recommend that you look at the center area of the viewfinder.

Checking the supplied items

Consult your Sony dealer or local authorized Sony service facility if all the accessories are not supplied.

The number in parentheses indicates the number of pieces.

- Camera (1)
- BC-VM10A Battery charger (1)

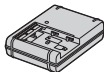

- Power cord (mains lead) (1)* (not supplied in the U.S.A. and Canada)



* Multiple power cords may be supplied with your camera. Use the appropriate one that matches your country/region.

- Rechargeable battery pack NP-FM500H (1)



- Shoe adaptor (1)/Connector protect cap (1) (Attached on the Shoe adaptor)



- USB cable (1)



- Shoulder strap (1)

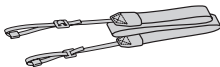

- Body cap (1) (Attached on the camera)



- Shoe Cap (1) (Attached on the camera)
- Eyepiece cup (1) (Attached on the camera)
- CD-ROM (1)
 - Application Software for α camera
 - α Handbook (This manual)
- Instruction Manual (1)

Identifying parts

See the pages in parentheses for details of operation.

Front side

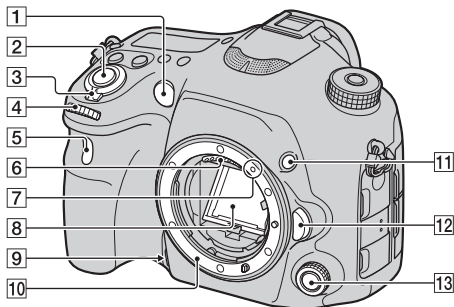

1 AF illuminator (100)/Self-timer lamp (111)

2 Shutter button (63)

3 Power switch (57)

4 Front control dial

5 Remote sensor (114)

6 Lens contacts*

7 Mounting index (55)

8 Mirror*

9 Preview button (42, 80, 176)

10 Mount

11 Custom button (42, 122, 177)





12 Lens release button (56)

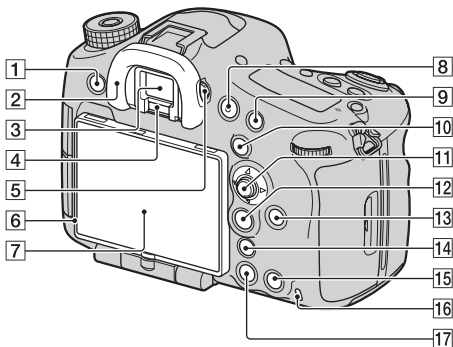

13 Silent multi-controller (32)

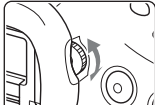
* **Do not directly touch these parts.**

Rear side







- 1** MENU button (37)
- 2** Eyepiece cup (62)
- 3** Viewfinder*
- When you look into the viewfinder, the viewfinder mode is activated, and when you take your face away from the viewfinder, the viewing mode returns to the LCD screen mode.
- 4** Eyepiece sensors (62)
- 5** Diopter-adjustment dial
- Adjust the diopter-adjustment dial to your eyesight until the display appears clearly in the viewfinder.
- 
- 6** Light sensor (177)
- 7** LCD screen (25, 59, 87, 165)
- 8** MOVIE button (42, 65)
- 9** For shooting: AF/MF (Auto focus/manual focus) button (42, 105, 176)
For viewing:  (Enlarge) button (160)
- 10** For shooting: AEL (AE lock) button (41, 83, 108, 176)/ SLOW SYNC button (117)
For viewing:  (Image index) button (161)
- 11** Multi-selector
- 12** For shooting: Fn (Function) button (34, 35)
For viewing:  (Image rotation) button (162)

- 13** DISP (Display) button (87, 165)
- 14**  (Smart teleconverter) button (42, 147)/Zoom button (147)/Focus Magnifier button (103)
- 15** For shooting: AF RANGE button (98)
For viewing:  (Delete) button (67)
When the Fn screen or menu screen is displayed: In-Camera Guide button (48)
- 16** Access lamp (53)
- 17**  (Playback) button (66)

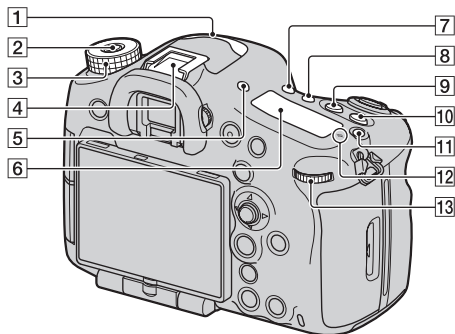
* **Do not directly touch this part.**

Top side



- 1 Microphone* (159)
- 2 Mode dial lock release button (68)
- 3 Mode dial (68)
- 4 Multi interface shoe** (24, 115)
- Some of the accessories may not be inserted fully and protrude backward from the Multi interface shoe. However, the accessory reaches the front end of the shoe, the connection is completed.
- 5 FINDER/LCD button (179)
- 6 Display panel (29)
- 7  /  (Drive) button (110)
- 8 WB (White balance) button (133)
- 9  (Exposure) button (106)
- 10 ISO button (41, 124, 176)
- 11 Display panel illumination button (29)
- 12  Image sensor position mark (94)
- 13 Rear control dial
- * **Do not cover this part during movie recording. Doing so may cause noise or lower the volume.**
- ** **For details on compatible accessories of the Multi interface shoe, visit the Sony web site in your area, or consult your Sony dealer or local authorized Sony service facility.**

**Accessories for the
Accessory Shoe can also
be used.**

**Operations with other
manufactures'
accessories are not
guaranteed.**

ni Multi
Interface Shoe

Accessory Shoe

Sides

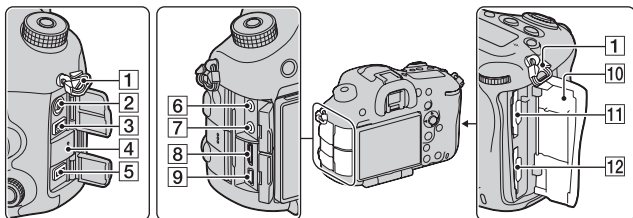

Before use

1 Hooks for shoulder strap

- Attach both ends of the strap onto the camera.

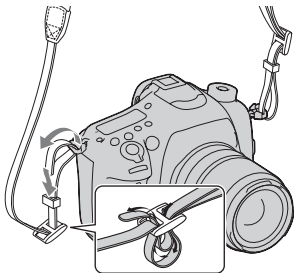
**2** ⚡ (Flash sync) terminal (118)**3** REMOTE terminal

- When connecting the RM-L1AM Remote Commander (sold separately) to the camera, insert the plug of the Remote Commander into the REMOTE terminal, aligning the guide of the plug with the guide of the REMOTE terminal. Make sure

that the cord of the Remote Commander faces forward.

4 Speaker**5** DC IN terminal

- When connecting the AC-PW10AM AC Adaptor (sold separately) to the camera, turn the camera off, then plug the connector of the AC Adaptor to the DC IN terminal on the camera.

6 (Microphone) jack

- When an external microphone is connected, the microphone is turned on automatically. If the external microphone is a plug-in-power type, the power of the microphone is supplied by the camera.

7 (Headphones) jack (158)**8** HDMI terminal (172)**9** (USB) terminal (205)**10** Memory card cover (51)

11 SLOT1 (Memory card slot 1)

(51)

- Available to either SD cards or “Memory Stick PRO Duo” media

12 SLOT2 (Memory card slot 2)

(51)

- Available to SD cards only

Bottom

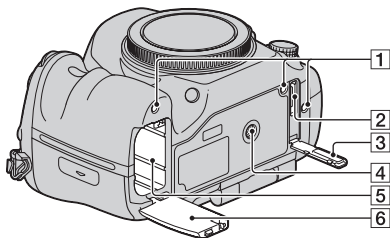

Before use

- 1 Guide holes for the Vertical Grip
 - These holes are used when you connect the Vertical Grip (sold separately) to the camera. Be sure to keep dust or debris from getting inside the holes.
- 2 Connector for the Vertical Grip
- 3 Connector cover for the Vertical Grip
- 4 Tripod receptacle
 - Use a tripod with a screw length of less than 5.5 mm (7/32 inch). You will be unable to firmly secure the camera to tripods with a screw length of 5.5 mm (7/32 inch) or longer, and attempting to do so may damage the camera.
- 5 Battery insertion slot (51)
- 6 Battery cover (51)

Shoe adaptor

Remove the Shoe Cap attached to the camera and attach the Shoe adaptor to the camera so that you can attach accessories compatible with a conventional Accessory Shoe (Auto-lock Accessory shoe).

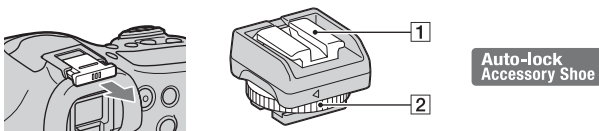

① Auto-lock Accessory shoe

② Lock knob

③ Tighten the Lock knob.

How to attach the Lock knob

① Remove the Connector protect cap from the shoe.

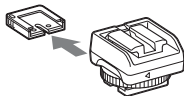

② Loosen the Lock knob and insert the Shoe adaptor into the shoe.

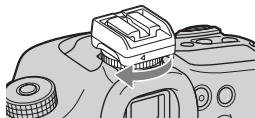
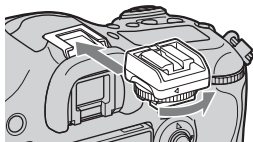

- Do not force the knob to turn after it locks.
- When you attach the Shoe adaptor to the camera, insert the Shoe adaptor all the way in.
- After you remove the Shoe adaptor from the camera, attach the Connector protect cap to the Shoe adaptor for storing the cap.

List of icons on the screen

List of icons on the LCD screen

The status of the LCD screen is set to “for the viewfinder mode (using the viewfinder for monitoring)” in the default settings.

Pressing the DISP button changes the screen status to “for the LCD screen mode.” You can also display the digital level gauge or histogram (page 87).

For the viewfinder mode

In Auto Mode or Scene Selection mode

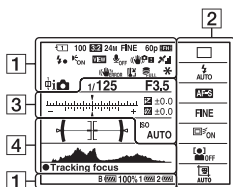

In Tele-zoom Cont. Priority AE/P/A/S/M/ Sweep Panorama mode

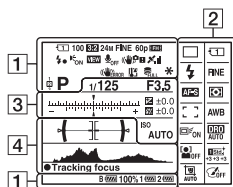

For the LCD screen mode

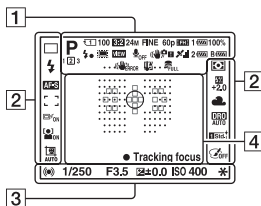

For playback (Basic information display)

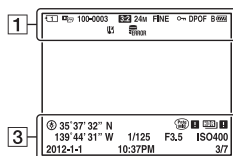

Display	Indication
	Remaining battery warning (53)

2

Display	Indication
	Drive mode (110)
	Flash mode (115)/Red-eye reduction (40)
	Focus mode (91)
	AF area (95)
	Object tracking (95)
	Face Detection (141)/Smile Shutter (145)
	Metering mode (109)
	White balance (Auto, Preset, Custom, Color filter) (133)
	D-Range Optimizer (126)/Auto HDR (127)
	Creative Style (130)/Contrast, Saturation, Sharpness











Display	Indication
	Picture Effect (129)
	Auto Portrait Framing (143)

3

Display	Indication
	EV scale (83, 106, 113)
	Exposure compensation (106)/Metered Manual (83)
	Flash compensation (120)
	Recording time of the movie (m:s)
	Focus (63, 93)
	Shutter speed (80)
	Aperture (78)
	ISO sensitivity (124)
	AE lock (108)/FEL lock (122)
	GPS information (SLT-A99V only)
	Latitude and longitude display (SLT-A99V only)
	Auto HDR image warning (127)
	Picture Effect error (130)
	Histogram (89)
	Date of recording

Display	Indication
3/7	File number/Number of images in the view mode

4

Display	Indication
	Spot metering area (109)
	AF area (95)
	Assist area (92)
	Digital level gauge (88)
	Histogram (89)
	Smart teleconverter (147)
	Smart Zoom/Clear Image Zoom/Digital Zoom
	Shutter speed indicator (88)
	Aperture indicator (88)
	AF Range Control (98)
● Tracking focus	Tracking focus (95)
	Audio level (157)

List of icons on the display panel

You can adjust the shutter speed, aperture, exposure compensation, flash compensation, ISO sensitivity, white balance, drive mode and image quality by checking the display panel on the top of the camera.



Shutter speed (80)/ Aperture (78)		Exposure (106)/Flash compensation (120)	
ISO sensitivity (124)		White balance (133)	
Drive mode (110)		Image quality (139)	
Remaining battery (53)		Remaining number of recordable images*	

* Even when the remaining number of recordable images is more than 9,999, “9999” is displayed on the display panel.

To turn on the backlight of the display panel









Press the display panel illumination button on the top. Pressing again turns off the backlight.

Display panel illumination button



Functions that can be operated with the buttons/dial

You can set up or operate various functions with these buttons/dial.
For the location of the buttons/dial, see “Identifying parts” (page 16).

 button (110)	Selects the drive mode.
WB button (133)	Adjusts the white balance.
 button (106)	Compensates the exposure.
ISO button (124)	Adjusts the ISO sensitivity.
Mode dial (68)	Switches the exposure mode. Rotate the dial while pressing the mode dial lock release button.
FINDER/LCD button (179)	Switches the display between the LCD screen and the viewfinder.
Display panel illumination button (29)	Turns on the backlight of the display panel.
MENU button (37)	Displays the menu screen for setting up the menu item.
MOVIE button (42, 65)	Records movies.
AEL button (108)/SLOW SYNC button (117)/ button (161)	Fixes the exposure of the entire screen./Shoots with the flash with a slower shutter speed./Displays multiple images on the screen simultaneously.
AF/MF button (105)/ button (160)	Switches the autofocus and manual focus temporarily./ Scales an image up when viewing images.
Fn button (31, 34, 35)/ button (162)	Displays the setup screen of the function that is set using the Fn button. In viewfinder mode, switches to the Quick Navi screen./Rotates images.
DISP button (87, 165)	Switches the recording information display of the viewfinder or the LCD screen.
 button (147)/Zoom button (147)/Focus Magnifier button (103)	Zooms in to the center of an image./Zooms in holding the current resolution of the image./Allows you to check the focus by enlarging the image before shooting.
 button (66)	Plays back images.
AF RANGE button (98)/In-Camera Guide button (48)/ button (67)	Limits the available operating range of autofocus./ Displays a In-Camera Guide./Deletes images.
Preview button (80)	Checks blurring of the background.
Custom button (42, 122, 177)	Assigns a frequently-used function to the button. The FEL lock function is assigned in the default settings.

**Silent multi-controller
(32)**

Adjusts the setting silently.

How to use the Quick Navi screen

Using the Quick Navi screen, you can change settings directly on the recording information display when the screen mode is set to [For viewfinder] (Quick Navi).

1 Press the DISP button to set the screen mode to [For viewfinder] (page 87).

2 Press the Fn button to switch to the Quick Navi screen.

In Auto Mode or Scene Selection mode

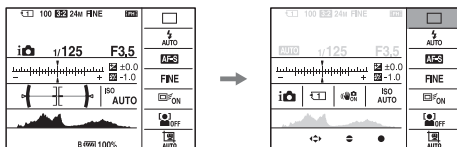

In Tele-zoom Cont. Priority AE/P/A/S/M/Sweep Panorama mode

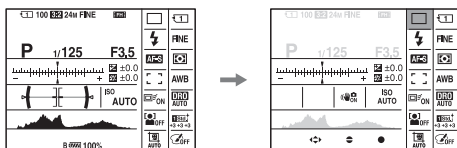

3 Select the desired item with ▲/▼/◀/▶ on the multi-selector.

4 Set the item with the front or rear control dial.

- Select an option with the front control dial and adjust it with the rear control dial.
- Pressing the center of the multi-selector turns on the designated screen used to set up the selected item.
- Pressing the Fn button again turns off the Quick Navi screen and the screen goes back to the original one.

Functions available on the Quick Navi screen

Auto Mode/Scene Selection/Tele-zoom Cont. Priority AE/Select Recording Media/Quality/SteadyShot (for still images)/Drive Mode/Flash Mode/Focus Mode/AF area/Object Tracking/Smile/Face Detect./Metering Mode/White Balance/DRO/Auto HDR/Creative Style/Picture Effect/Auto Port. Framing/Exposure Comp./Flash Comp./ISO

Notes

- Gray items on the Quick Navi screen are not available.
- When using Creative Style (page 130), some of the setup tasks can be accomplished only on a designated screen.

How to use the silent multi-controller

You can set an item without changing the screen using the silent multi-controller. Since the dial is designed to reduce the sound of the dialing operation, you can reduce the sound of the dialing operation during movie recording.

You can assign separate functions to the dial for still image shooting and movie recording (page 33).

1 Press the button so that the setup screen appears.

- [Focus Mode] is assigned to the button for still image shooting, and [Audio Rec Level] is assigned to the same button for movie recording in the default settings.

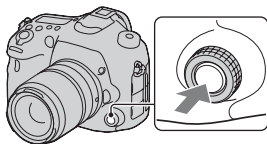

2 Rotate the dial to select the desired setting.

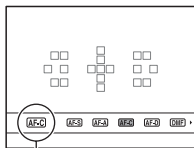
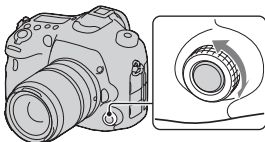

Current setting

Functions list

3 Press the button to execute.

To assign other functions to the Silent Multi-Controller

Pressing and holding the button opens the screen used for assigning functions to the Silent Multi-Controller.

Rotate the dial to select a function. You can also select a function from: MENU button → 3 → [Silent Controller] or MENU button → 1 → [Silent Controller].

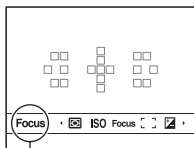

Current function

Functions available

Still image: Focus Mode/AF area/Select AF area/Exposure Comp./Metering Mode/ISO

Movie: Audio Rec Level/Focus Mode/AF area/Select AF area/Exposure Comp./Metering Mode/ISO/Shutter speed/Aperture

Selecting a function with the Fn (Function) button

This button is used for setting up or executing functions used frequently in shooting, except for functions from the Quick Navi screen.

1 Press the DISP button to set the screen mode to other than [For viewfinder] (page 87).

2 Press the Fn button.

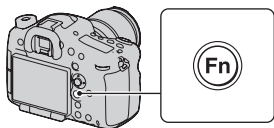

3 Select the desired item with ▲/▼/◀/▶ on the multi-selector, then press the center ● to execute.

The setup screen appears.

4 Following the operation guide, select and execute the desired function.

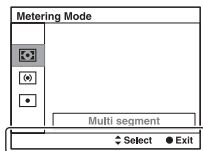

Operation guide

To set up the camera directly from the recording information screen

Turn the front control dial without pressing the center ● in step 3. You can set up the camera directly from the recording information screen.

Additionally, some functions can be fine-tuned using the rear control dial.

Functions that can be selected with the Fn (Function) button

The functions that can be selected with the Fn button are as follows:

Auto Mode (69)	Selects the automatic shooting mode. (Intelligent Auto/Superior Auto)
Scene Selection (71)	Selects an appropriate mode from among the Scene Selection preset settings to suit shooting conditions. (Portrait/Sports Action/Macro/Landscape/Sunset/Night Scene/Hand-held Twilight/Night Portrait)
Movie (153)	Selects the exposure mode for movie recording to suit your subject or your effect. (P/A/S/M)
Tele-zoom Cont. Priority AE (76)	Sets the speed for continuous shooting. (T10/T8)
Drive Mode (110)	Sets the drive mode such as continuous shooting. (Single Shooting/Cont. Shooting/Self-timer/Bracket: Cont./Single Bracket/WB bracket/DRO Bracket/Remote Cdr.)
Flash Mode (115)	Sets the flash mode of a flash (sold separately). (Flash Off/Autoflash/Fill-flash/Rear Sync./Wireless)
Focus Mode (91)	Selects the focus mode. (Single-shot AF/Automatic AF/Continuous AF/Depth Map Assist Continuous AF/DMF/Manual Focus)
AF area (95)	Selects the area of focus. (Wide/Zone/Spot/Local)
Object Tracking (95)	Keeps the focus on a subject while tracking it. (Off/On/On(Tracking focus w/ shutter))
Smile/Face Detect. (141, 145)	Automatically captures people's face(s) with the optimal focus and exposure./Shoots when a smile is detected. (Face Detection Off/Face Detection On (Regist. Faces)/Face Detection On/Smile Shutter)
Auto Port. Framing (143)	Analyzes the scene when capturing a face and saves another image with a more impressive composition. (Auto/Off)
ISO (124)	Sets the sensitivity to light. The larger the number, the faster the shutter speed. (Multi Frame Noise Reduct./ISO AUTO/ISO 50 to 25600)
Metering Mode (109)	Selects the method for measuring brightness. (Multi segment/Center weighted/Spot)

Flash Comp. (120)	Adjusts the amount of flash light. (+3.0EV to -3.0EV)
White Balance (133)	Adjusts the color tone of images. (Auto WB/Daylight/Shade/Cloudy/Incandescent/Fluor.: Warm White/Fluor.: Cool White/Fluor.: Day White/Fluor.: Daylight/Flash/C.Temp./Filter/Custom 1-3)
DRO/Auto HDR (126)	Compensates for the brightness and contrast automatically. (Off/D-Range Opt./Auto HDR)
Creative Style (130)	Selects your desired image processing. (Standard/Vivid/Neutral/Clear/Deep/Light/Portrait/ Landscape/Sunset/Night Scene/Autumn leaves/Black & White/Sepia/Style Box1-6)
Picture Effect (129)	Shoots with the desired effect filter to achieve more impressive expression. (Off/Toy Camera/Pop Color/Posterization/Retro Photo/Soft High-key/Partial Color/High Contrast Mono./Soft Focus/ HDR Painting/Rich-tone Mono./Miniature)

The functions selected with the MENU button

You can set up the basic settings for the camera as a whole or execute functions such as shooting, playback, or other operations.

Press the MENU button, then set up the desired item with ▲/▼/◀/▶ on the multi-selector, then press the center of the multi-selector.

Select a page of the menu

Select an item on the menu



Still shooting menu



Image Size (137)	Selects the size of still images. (L/M/S)
Aspect Ratio (139)	Selects the aspect ratio for still images. (3:2/16:9)
Quality (139)	Sets the image quality for still images. (RAW/RAW & JPEG/Extra fine/Fine/Standard)
Panorama: Size (137)	Selects the size of panoramic images. (Standard/Wide)
Panorama: Direction (75)	Sets the shooting direction for panoramic images. (Right/Left/Up/Down)



Clear Image Zoom (149)	Zooms an image with higher quality than Digital Zoom. (On/Off)
Digital Zoom (149)	Zooms an image with higher magnification than Clear Image Zoom. (On/Off)
Long Exposure NR (150)	Sets noise reduction processing for shots in which shutter speed will be 1 second or longer. (On/Off)

High ISO NR (150)	Sets noise reduction processing for high-sensitivity shooting. (Normal/Low/Off)
Flash control (121)	Sets the method for determining the intensity of flash output. (ADI flash/Pre-flash TTL)
AF Illuminator (100)	Sets the AF illuminator, which sheds light on a dark scene to aid focusing. (Auto/Off)



SteadyShot (60)	Sets SteadyShot for still image shooting. (On/Off)
AF drive speed	Selects the focusing speed in autofocus mode. When [Slow] is selected in macro shooting, focusing is easier achieved. (Fast/Slow)
Color Space (151)	Changes the range of reproducible colors. (sRGB/AdobeRGB)
Silent Controller (33)	Assigns the desired function to the silent multi-controller for still image shooting. (Focus Mode/AF area/Select AF area/Exposure Comp./ISO/Metering Mode)



Exposure step	Selects the size of the increment step for shutter speed, aperture, and exposure. (0.5 EV/0.3 EV)
Priority setup	Sets whether or not to release the shutter even when the focus is not confirmed in autofocus mode. (AF/Release)
AF w/ shutter	Sets whether or not to activate the autofocus by pressing the shutter button halfway down. This is convenient when you want to adjust the focus and exposure separately. (On/Off)
AEL w/ shutter	Sets whether or not to adjust the exposure by pressing the shutter button halfway down. This is convenient when you want to adjust the focus and exposure separately. (On/Off)
Memory (190)	Registers combinations of frequently used modes and settings and allows easy recall of those combinations with the mode dial. (1/2/3)

Movie shooting menu

















File Format (155)	Selects the movie file format. (AVCHD/MP4)
Record Setting (155)	Selects the quality and size of the recorded movie frame. (60i 24M(FX)/50i 24M(FX)/60i 17M(FH)/50i 17M(FH)/60p 28M(PS)/50p 28M(PS)/24p 24M(FX)/25p 24M(FX)/24p 17M(FH)/25p 17M(FH)/1440×1080 12M/VGA 3M)
SteadyShot (60)	Sets SteadyShot for movie recording. (On/Off)
AF Tracking Duration (153)	Sets the tracking sensitivity of the autofocus feature for movie recording. (High/Mid/Low)
Auto Slow Shutter (154)	Sets whether or not to automatically adjust the shutter speed to a slower setting during movie recording, when the subject is in a dark situation. (On/Off)
Silent Controller (32, 33)	Assigns the desired function to the silent multi-controller for movie recording. (Audio Rec Level/Focus Mode/AF area/Select AF area/Exposure Comp./ISO/Metering Mode/Shutter Speed/Aperture)





















Audio Recording (159)	Sets whether or not to record audio when shooting a movie. (On/Off)
Wind Noise Reduct. (159)	Reduces wind noise during movie recording. (On/Off)
Audio Rec Level (157)	Adjusts the audio recording level. (0 to 31)
Audio Level Display (157)	Sets whether or not to display the audio level. (On/Off)
Audio Output Timing (158)	Provides measures to reduce echo for movie recording. (Live/Lip Sync)







Custom menu

   1 2 3 4 5 6    	
Eye-Start AF	Sets whether or not to use auto focus when you look through the viewfinder. (On/Off)
FINDER/LCD Setting (179)	Sets the method for switching between the viewfinder and LCD screen. (Auto/Manual)
Red Eye Reduction	Reduces the red-eye phenomenon during flash use. (On/Off)
Release w/o Lens (175)	Sets whether shutter can open when lens is not attached. (Enable/Disable)
S. Auto Cont. Shooting (70)	Sets whether or not to shoot continuously in Superior Auto mode. (Auto/Off)
S. Auto Image Extract. (70)	Sets whether or not to save all the images that were shot continuously in Superior Auto mode. (Auto/Off)





   1 2 3 4 5 6    	
Grid Line (175)	Sets a grid line display to enable alignment to a structural outline. (Rule of 3rds Grid/Square Grid/Diag. + Square Grid/Off)
Auto Review (175)	Displays the captured image after shooting it automatically. You can set the duration of time the image is to be displayed. (10 Sec/5 Sec/2 Sec/Off)
DISP Button(Monitor) (87)	Allows you to select the available screen display modes of the LCD screen that can be selected by pressing the DISP button. (Graphic Display/Display All Info./No Disp. Info./Level/Histogram/For viewfinder)
DISP Button(Finder) (87)	Allows you to select the available screen display modes of the viewfinder that can be selected by pressing the DISP button. (Graphic Display/Display All Info./No Disp. Info./Level/Histogram)



   1 2 3 4 5 6    	
AF RANGE Button (98)	Selects the function to be used with the AF RANGE button. (AF Range Control/In-Camera Guide)
AF Range Control Assist	Sets whether or not to show the status that the subject is located within the focus range on the screen using the assist area when the AF Range Control function is activated (available only when an AF-D compatible lens is attached). (On/Off)
Peaking Level (102)	Enhances the outline of in-focus ranges with a specific color. (High/Mid/Low/Off)
Peaking Color (103)	Sets the color used for the peaking function. (Red/Yellow/White)
Live View Display (89)	Sets whether or not to display the effect of a function on the screen, such as the effect of the exposure compensation value. (Setting Effect ON/Setting Effect OFF)

   1 2 3 4 5 6    	
Func. of AEL button (176)	Assigns the desired function to the AEL button. (Exposure Comp./Drive Mode/Flash Mode/Focus Mode/AF area/Smile/Face Detect./Auto Port. Framing/ISO/Metering Mode/Flash Comp./White Balance/DRO/Auto HDR/Creative Style/Picture Effect/Image Size/Quality/AEL hold/AEL toggle/  AEL hold/  AEL toggle/FEL Lock hold/FEL Lock toggle/Object Tracking/AF/MF Control Hold/AF/MF Control Toggle/AF lock/AF On/Aperture Preview/Shot. Result Preview/Focus Magnifier/Memory)
ISO Button (176)	Assigns the desired function to the ISO button. (Exposure Comp./Drive Mode/Flash Mode/Focus Mode/AF area/Smile/Face Detect./Auto Port. Framing/ISO/Metering Mode/Flash Comp./White Balance/DRO/Auto HDR/Creative Style/Picture Effect/Image Size/Quality/AEL hold/AEL toggle/  AEL hold/  AEL toggle/FEL Lock hold/FEL Lock toggle/Object Tracking/AF/MF Control Hold/AF/MF Control Toggle/AF lock/AF On/Aperture Preview/Shot. Result Preview/Focus Magnifier/Memory)

AF/MF button (176)	Assigns the desired function to the AF/MF button. (Exposure Comp./Drive Mode/Flash Mode/Focus Mode/AF area/Smile/Face Detect./Auto Port. Framing/ISO/Metering Mode/Flash Comp./White Balance/DRO/Auto HDR/Creative Style/Picture Effect/Image Size/Quality/AEL hold/AEL toggle/  AEL hold/  AEL toggle/FEL Lock hold/FEL Lock toggle/Object Tracking/AF/MF Control Hold/AF/MF Control Toggle/AF lock/AF On/Aperture Preview/Shot. Result Preview/Focus Magnifier/Memory)
Custom button (177)	Assigns the desired function to the custom button. (Exposure Comp./Drive Mode/Flash Mode/Focus Mode/AF area/Smile/Face Detect./Auto Port. Framing/ISO/Metering Mode/Flash Comp./White Balance/DRO/Auto HDR/Creative Style/Picture Effect/Image Size/Quality/AEL hold/AEL toggle/  AEL hold/  AEL toggle/FEL Lock hold/FEL Lock toggle/Object Tracking/AF/MF Control Hold/AF/MF Control Toggle/AF lock/AF On/Aperture Preview/Shot. Result Preview/Focus Magnifier/Memory)
Preview Button (176)	Assigns the desired function to the preview button. (Exposure Comp./Drive Mode/Flash Mode/Focus Mode/AF area/Smile/Face Detect./Auto Port. Framing/ISO/Metering Mode/Flash Comp./White Balance/DRO/Auto HDR/Creative Style/Picture Effect/Image Size/Quality/AEL hold/AEL toggle/  AEL hold/  AEL toggle/FEL Lock hold/FEL Lock toggle/Object Tracking/AF/MF Control Hold/AF/MF Control Toggle/AF lock/AF On/Aperture Preview/Shot. Result Preview/Focus Magnifier/Memory)
Smart Telecon. Button (103, 147)	Selects the function to be used with the  button. (Smart Telecon./Focus Magnifier/Zoom)
Focus Hold Button	Sets the function of the focus hold button of the lens. When you select [Preview Button], the function selected with [Preview Button] is assigned. (Focus Hold/Preview Button)



MOVIE Button	Selects the appropriate mode for the MOVIE button. (Always/Movie Mode Only)
Ctrl dial setup	Sets the functions of the front and rear control dials when the exposure mode is set to M. Dials can be used for adjusting shutter speed and aperture. ( SS  F/no. /  F/no.  SS)

Dial exp.comp (107)	Compensates the exposure with the front or rear control dial. (Off/  Front dial/  Rear dial)
Exp.comp.set	Sets whether or not to compensate the exposure within the flash light range. (Ambient&flash/Ambient only)
Bracket order	Selects the order in exposure bracket and white balance bracket shooting. (0 → - → +/- → 0 → +)

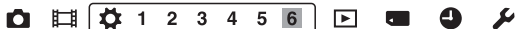

Lens Comp.: Shading (181)	Compensates for the shaded corners of the screen caused by the lens attached. (Auto/Off)
Lens Comp.: Chro. Aber. (181)	Reduces the color deviation at the corners of the screen caused by the lens attached. (Auto/Off)
Lens Comp.: Distortion (181)	Compensates for distortion on the screen caused by the lens attached. (Auto/Off)
Front Curtain Shutter (177)	Sets whether or not to use the electronic front curtain shutter function. (On/Off)
Face Priority Tracking (97)	Sets whether to preferentially-track a certain face or not when the camera detects that face during object tracking. (On/Off)
Face Registration (142)	Registers or changes the person to be given priority in the focus. (New Registration/Order Exchanging/Delete/Delete All)

Playback menu



Still/Movie Select (160)	Allows you to determine how to group the playback images (View mode). (Folder View(Still)/Folder View(MP4)/AVCHD View)
Delete (170)	Deletes images. (Multiple Img./All in Folder/All AVCHD view files)
Slide Show (163)	Shows a slide show. (Repeat/Interval/Image Type)

Image Index (161)	Sets the number of images displayed on one page of the image index screen. (4 Images/9 Images)
Protect (167)	Protects or cancels protection for an image. (Multiple Img./Cancel All Images/Cancel All Movies(MP4)/Cancel All AVCHD view files)
Specify Printing (168)	Specifies or unspecifies the images for DPOF. (DPOF Setup/Date Imprint)

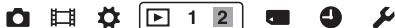

Select Playback Media (160)	Selects the memory card slot to be used for playback. (Slot 1/Slot 2)
Copy (169)	Duplicates images in a memory card.
Volume Settings	Sets the volume for movie playback. (0 to 7)
Playback Display (164)	Sets how to play back an image recorded in portrait. (Auto Rotate/Manual Rotate)

Memory Card Tool menu



Select Recording Media (52)	Selects the memory card slot to be used for recording. (Slot 1/Slot 2)
Recording Mode (182)	Selects the recording method to record on memory cards. (Standard/Simult. Rec (Still)/Simult. Rec (Movie)/Sim. Rec (Still/Movie)/Sort(JPEG/RAW)/Sort(Still/Movie))
Format (183)	Formats the memory card.
File Number (183)	Sets the method used to assign file numbers to still images and MP4 movies. (Series/Reset)
Folder Name (183)	Sets the folder format for still images. (Standard Form/Date Form)
Select REC Folder (184)	Changes the selected folder for storing still images and MP4 movies.
New Folder (184)	Creates a new folder for storing still images and MP4 movies.



Recover Image DB (185)	Recovers the image database file and enables recording and playback.
Display Card Space	Displays the remaining recording time of movies and the recordable number of still images on the memory card.

Clock setup menu



Date/Time Setup (58)	Sets date and time, and daylight savings.
Area Setting (58)	Sets the location of where the camera is used.

Setup menu



Menu start	Sets the default position of the cursor on the menu to the top item or the last-selected item. (Top/Previous)
Delete confirm.	Sets [Delete] or [Cancel] as the default setting for the delete confirmation screen. ("Delete" first/"Cancel" first)
Mode Dial Guide	Displays an explanation of each shooting mode and also allows you to select another shooting mode. (On/Off)
LCD Brightness (177)	Sets the brightness of the LCD screen. (Auto/Manual/Sunny Weather)
Viewfinder Bright. (178)	Sets the brightness of the viewfinder. (Auto/Manual)
Viewfinder Color Temp.	Sets the color temperature of the screen in the viewfinder. Setting it toward + makes the color cooler, and toward - makes the color warmer. (+2 to 0 to -2)



GPS Settings (187) (SLT-A99V only)	Sets the GPS functions.
Power Save (178)	Sets the response level to be used to activate the power save mode. (Max/Standard)

Power Saving Start Time (179)	Sets the interval after which power save mode engages. (30 Min/5 Min/1 Min/20 Sec/10 Sec)
HDMI Resolution (172)	Sets the resolution when the camera is connected to an HDMI TV. (Auto/1080p/1080i)
CTRL FOR HDMI (174)	Operates the camera from a TV that supports "BRAVIA" Sync. (On/Off)
HDMI Info. Display (173)	Displays images on the screen of an HDMI TV connected without displaying recording information. (On/Off)



Upload Settings* (185)	Sets whether to use the upload function of the camera with an Eye-Fi card. (On/Off)
USB Connection (204)	Sets the USB connection method, appropriate to the computer or USB device. (Auto/Mass Storage/MTP/PC Remote)
USB LUN Setting (204)	Allows the computer to recognize both the memory cards during a USB connection. (Multi/Single)
Audio signals	Sets whether or not to use the beep sound when the focus is achieved or the self-timer is working. (On/Off)
PAL/NTSC Selector (Only for 1080 50i-compatible models) (180)	Plays back movies recorded with the camera on an NTSC system TV. (PAL/NTSC)
APS-C Size Capture (179)	Sets whether or not to record with an APS-C size-equivalent area. (On/Auto)
AF Micro Adj. (101)	Allows you to make fine adjustments to the position of the focus. (AF Adjustment Setting/amount/Clear)

* Appears when an Eye-Fi card is inserted in the memory card SLOT1 in the camera.



Version (198)	Displays the camera software version.
Language	Selects the language.
Cleaning Mode (224)	Starts the cleaning mode to clean the image sensor.
Demo Mode	Sets the demonstration playback of a movie to on or off. (On/Off)
Initialize (191)	Restores the settings to their defaults. (Reset Default/Rec mode reset/Custom reset)

Using the In-Camera Guide

The AF RANGE button is equipped with both an In-Camera Guide feature and a delete feature.

When you press the AF RANGE button on the Fn screen or menu screen, a help guide explaining the currently selected function or setting appears automatically.

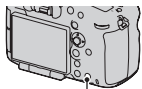

AF RANGE button

MENU button →  **3** → **[AF RANGE Button]** → **[In-Camera Guide]**

Charging the battery pack

When using the camera for the first time, be sure to charge the NP-FM500H “InfoLITHIUM” battery pack (supplied).

The “InfoLITHIUM” battery pack can be charged even when it has not been fully depleted.

It can also be used when it has not been fully charged.

The battery pack is discharged little by little without using it. To avoid missing the opportunity to shoot, charge it before use.

1 Insert the battery pack onto the battery charger.

Push the battery pack until it clicks.

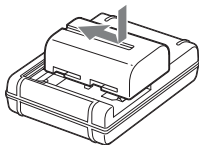

2 Connect the battery charger to the wall outlet (wall socket). For the U.S.A and Canada

Light on: Charging

Light off: Charge completed

Charging time	About 175 minutes
---------------	-------------------

- When charging a fully depleted battery pack at a temperature of 25°C (77°F).
- The CHARGE lamp turns off when charging is completed.

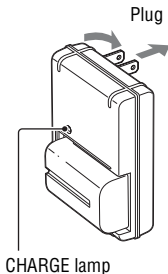

For countries/regions other than the U.S.A. and Canada

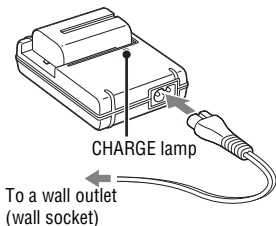

Notes

- The charging time differs depending on the remaining capacity of the battery pack or charging conditions.
- We recommend charging the battery pack in an ambient temperature of between 10°C to 30°C (50°F to 86°F). You may not be able to efficiently charge the battery pack outside of this temperature range.
- Connect the battery charger to the nearest wall outlet (wall socket).

Inserting the battery pack/memory card (sold separately)

This camera is equipped with 2 memory card slots; SLOT1 can be used with “Memory Stick PRO Duo” media or SD cards, but SLOT2 can be used only with SD cards.

- 1** While sliding the battery cover open lever, open the cover.

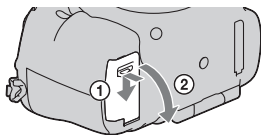

- 2** Firmly insert the battery pack all the way while pressing the lock lever with the tip of the battery.

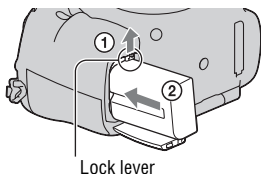

- 3** Close the cover.

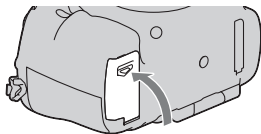

- 4** While sliding the memory card cover, open the cover.

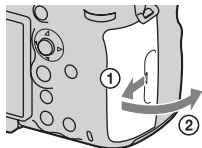

5 Insert a memory card.

- With the notched corner facing as illustrated, insert the memory card until it clicks into place.

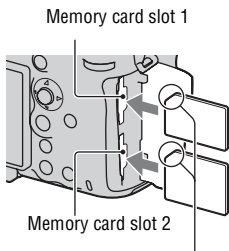

Ensure the notched corner faces correctly.

6 Close the cover.

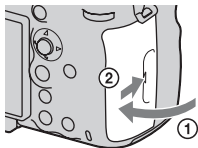

To select the memory card to be used for recording

[Slot 1] is selected in the default settings. Use slot 1 when you do not want to change the setting and intend to use only a single memory card.

MENU button → **1** → **[Select Recording Media]** → **Select the desired slot**

- You can also set [Select Recording Media] from the Quick Navi screen (page 31).

To record an image on both memory cards at the same time

You can record the same images on both memory cards at the same time or sort images onto the different memory cards by the type of image (page 182).

MENU button → **1** → **[Recording Mode]** → **Select the desired setting**

To remove the memory card

Check that the access lamp (page 18) is not lit, then open the memory card cover, and push the memory card once.

To check the remaining battery level

The supplied battery pack is a lithium-ion battery pack that has functions for exchanging information related to operating conditions with your camera. The remaining battery time in percent figures is displayed according to the operating conditions of your camera.

Battery level						"Battery exhausted."
	High Low					You cannot shoot any more pictures.

You can use 2 battery packs installed in the Vertical Grip (sold separately) by attaching it to the camera. Including the battery pack installed in the camera, this provides a total of 3 battery packs that are switched automatically.

You can check the status of these battery packs on the screen.

B The remaining battery level of the battery pack inserted in the camera

1 **2** The remaining battery level of the battery packs inserted in the Vertical Grip

For details on the Vertical Grip, refer to the operating instructions supplied with the Vertical Grip.

To remove the battery pack from the camera

Turn off the camera. Slide the lock lever in the direction of the arrow after confirming that the vibration of the camera has stopped and both the LCD screen and access lamp are turned off, then remove the battery pack. Be careful not to drop the battery pack.

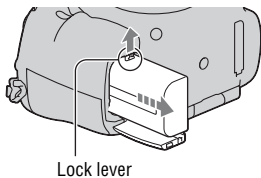

Lock lever

Compatible memory cards

The following memory cards are compatible with this camera. However, all memory cards are not guaranteed to work with this camera.

Types of memory card	Still images	Movies	Movies (Simult. Rec)	In this manual
Memory Stick PRO Duo	✓	✓* ¹	–	Memory Stick PRO Duo
Memory Stick PRO-HG Duo	✓	✓	✓	
SD memory card	✓	✓* ²	✓* ³	SD card
SDHC memory card	✓	✓* ²	✓* ³	
SDXC memory card	✓	✓* ²	✓* ³	

- MultiMediaCard cannot be used.

*1 “Memory Stick PRO Duo” media that match the Mark2

*2 SD cards that match the Class 4 or faster

*3 SD cards that match the Class 10 or faster, or the UHS-I (UHS Speed Class1) interface

Notes

- “Memory Stick PRO Duo” media cannot be used with slot 2.
- Images recorded on an SDXC memory card cannot be imported to or played on computers or AV devices that are not compatible with exFAT. Make sure that the device is compatible with exFAT before connecting it to the camera. If you connect your camera to an incompatible device, you may be prompted to format the card. Never format the card in response to this prompt, as doing so will erase all data on the card. (exFAT is the file system used on SDXC memory cards.)

Attaching a lens

1 Remove the body cap from the camera and the rear lens cap from the rear of the lens.

- When changing the lens, quickly change the lens away from dusty locations so as to keep dust or debris from getting inside the camera.
- When shooting, remove the front lens cap from the front of the lens.

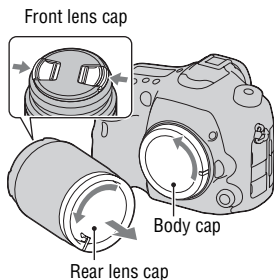

2 Mount the lens by aligning the orange index marks (mounting indexes) on the lens and camera.

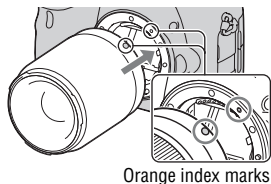

3 Turn the lens clockwise until it clicks into the locked position.

Be sure to put the lens on straight.

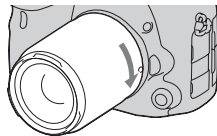

Notes

- When attaching a lens, do not press the lens release button.
- Do not use force when attaching a lens.
- E-mount lenses are not compatible with this camera.
- When a DT lens is attached or [APS-C Size Capture] is set to [On] in the  Setup menu, a live view image is displayed in full screen view on the LCD screen with the angle of view of the APS-C size. The live view image in the viewfinder is also displayed entirely and you can check the composition or effect using the whole screen.

- When you want to shoot full-frame images, use a lens designed for a full-frame camera.
- When you use a lens for which a tripod socket is provided, attach the lens onto the tripod using the tripod socket provided to help balance the weight of the lens.
- When carrying the camera with a lens attached, hold both the camera and the lens firmly.
- Do not hold the part of the lens that is extended for the zoom or focus adjustment.

To remove the lens

- 1 Press the lens release button all the way in and turn the lens counterclockwise until it stops.**

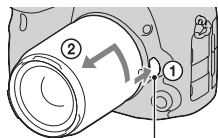

Lens release button

- 2 Attach the caps to the front and rear of the lens and the body cap to the camera.**

- Before you attach them, remove dust from them.

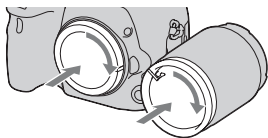

Note on changing the lens

When changing the lens, if dust or debris gets inside the camera and adheres to the surface of the image sensor (the part that converts the light to an electric signal), it may appear as dark spots on the image, depending on the shooting environment.

The camera is equipped with an anti-dust function to prevent dust from landing on the image sensor. However, quickly change the lens away from dusty locations when attaching/removing a lens.

Setting the date and time

When you turn the camera on for the first time or after you initialize the functions, the date/time setup screen appears.

1 Set the power switch to ON to turn the camera on.

The screen used for setting date and time appears.

- To turn the camera off, set it to OFF.

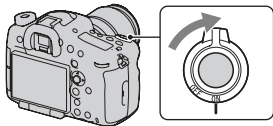

2 Verify that [Enter] is selected on the LCD screen, then press the center of the multi-selector.

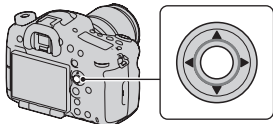

3 Select your area with ◀/▶ on the multi-selector, then press the center of the multi-selector.

4 Select each item with ◀/▶ and set the numeric value with ▲/▼.

[Daylight Svg.]: Turns on or off the daylight saving time setting.

[Date Format:]: Selects the format to display date.

- Midnight is indicated as 12:00 AM, and noon as 12:00 PM.

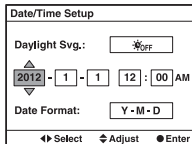
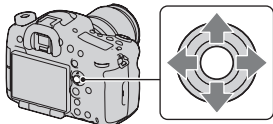

5 Repeat step 4 to set other items, then press the center of the multi-selector.

6 Verify that [Enter] is selected, then press the center of the multi-selector.

To cancel the date/time setting operation

Press the MENU button.

Setting up the date/time again

When you turn the camera on for the first time, the date/time setup screen appears automatically. The next time, set up the date and time from the menu.

MENU button →  **1** → [Date/Time Setup] or [Area Setting] (page 45)

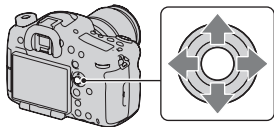

Maintaining the date and time setting

This camera has an internal rechargeable battery for maintaining the date and time and other settings regardless of whether the power is on or off, or the battery is installed or not (page 227).

Adjusting the angle of the LCD screen

Adjust the LCD screen to an easily viewable angle.

- Put your finger on the upper-left part of the LCD screen and draw it toward you.
- The LCD screen tilts 140 degrees upward and 180 degrees downward.
- The LCD screen rotates 180 degrees clockwise and 90 degrees counterclockwise.
- When the LCD screen is not used, it is recommended that you close it with the screen side facing to the camera.

Note

- When the LCD screen is open, the eyepiece sensors may not be able to function in situations involving low-position shooting. If you look into the viewfinder and the viewing mode does not switch from the monitor to the viewfinder automatically, press the FINDER/LCD button.

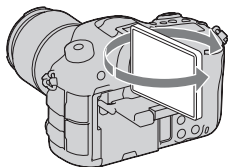
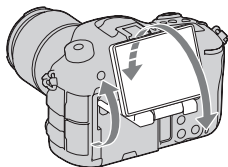
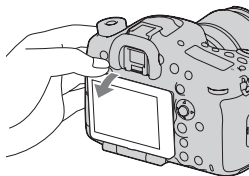



Shooting a clear image without camera shake

“Camera shake” refers to unwanted movement of the camera that occurs after the shutter button has been pressed, resulting in a blurred image. To reduce camera shake follow the instructions below.

Camera shake warning indicator

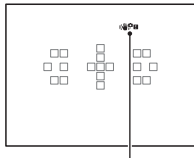
In situations where the camera may be subject to camera-shake, the  (Camera shake warning) indicator flashes. In this case, use a tripod or the flash.



 (Camera shake warning) indicator



Note

- The camera shake warning indicator does not appear in the following situations:
 - The exposure mode is set to M/S, or during movie recording.
 - When the viewing mode is set to [No Disp. Info.], [Level], or [Histogram] (page 87).

Using the SteadyShot function

The SteadyShot function is available with this camera to reduce camera shake. The SteadyShot function can be set separately for still image shooting and for movie recording.

The SteadyShot function is set to [On] for still image shooting and [Off] for movie recording in the default settings.

MENU button →  **3** or  **1** → [SteadyShot] → **Select the desired setting**

- You can also set the SteadyShot function used for still image shooting from the Quick Navi screen (page 31).

Notes

- The SteadyShot function may not work optimally when the power has just been turned on, right after you point the camera towards a subject, or when the shutter button has been pressed all the way down without stopping halfway.
- When using a tripod, deactivate the SteadyShot function because there is a potential for malfunction of the SteadyShot function.

Holding the camera properly

Stabilize your upper body and take a position that keeps the camera from moving.

In viewfinder mode

In viewfinder mode
(vertical position)

In LCD screen mode

**Point ①**

One hand holds the grip of the camera, and the other hand supports the lens.

Point ②

Take a secure stance with your feet shoulder-width apart.

Point ③

Lightly tuck your elbows against your body.

When shooting in a kneeling position, steady your upper body by placing your elbow on your knee.

Removing the Eyepiece cup

When attaching the FDA-A1AM Angle Finder (sold separately) to the camera, remove the Eyepiece cup.

Carefully slide the Eyepiece cup off by pushing on each side of the Eyepiece cup.

- Put your fingers under the Eyepiece cup, and slide it upward.

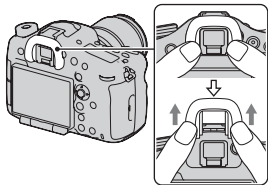

Note

- When an FDA-A1AM Angle Finder (sold separately) is attached to the camera, switch the display between the viewfinder and the LCD screen by setting [FINDER/LCD Setting] in the ⚙ Custom menu to [Manual] and pressing the FINDER/LCD button. Setting [Eye-Start AF] to [Off] is recommended because the eyepiece sensors located below the viewfinder may be activated.

Shooting still images

The “Auto Mode” allows you to easily shoot any subject under any conditions because the camera makes appropriate judgments on the situation to adjust the settings.

1 Set the mode dial to **AUTO** (Auto Mode).

- Rotate the mode dial while pressing the mode dial lock button on the center of the mode dial.

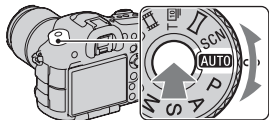

2 Hold the camera, monitoring your shot with the viewfinder.

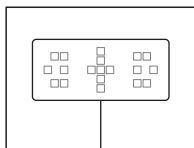

AF area

3 When using a zoom lens, turn the zoom ring, then decide on your shot.

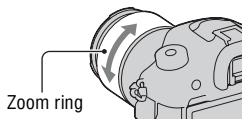

4 Press the shutter button halfway down to focus.

- When the focus is confirmed, ● or (●) (Focus indicator) lights up (page 93).

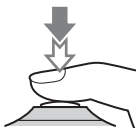

5 Press the shutter button fully down to shoot.

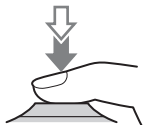

Recording movies

1 Press the MOVIE button to start recording.

- Movie recording can be started from any exposure mode.
- The camera continues to adjust the focus using [Continuous AF] when it is in autofocus mode (page 91).
- The shutter speed and aperture are adjusted automatically. If you want to set them to particular values, set them after the mode dial is set to  (Movie) (page 153).

MOVIE button



2 Press the MOVIE button again to stop recording.

Notes

- The sound of the camera and the lens in operation may be recorded while recording a movie. Using the silent multi-controller, you can reduce the sound of the dialing operation for adjustments you need to make (page 33). You can disable sound recording by setting [Audio Recording] to [Off] (page 159).
- The continuous recording time of a movie may be shorter, depending on the ambient temperature or the status of the camera. See “Notes on continuous movie recording.”
- When the  icon appears, the temperature of the camera is too high. Turn the camera off and wait until the temperature of the camera drops.

Playing back images

1 Press the  button.

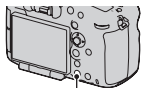

 button

2 Select an image with /▶ on the multi-selector.

- To play back movies, press the center of the multi-selector.

During movie playback	Multi-selector/Rear control dial operation/DISP button
To pause/resume	●
To fast-forward	▶
To fast-rewind	◀
To slow-forward	Rotate the rear control dial to the right during pause.
To slow-reverse	Rotate the rear control dial to the left during pause. <ul style="list-style-type: none">• The movie is played back frame-by-frame.
To adjust sound volume	▼ → ▲/▼
To display the information	DISP (Display) button

Note

- Movies recorded with other devices may not be played back on this camera.

Switching between still images and movies

To play back still images, set [Still/Movie Select] to [Folder View(Still)], and to play back movies, set [Still/Movie Select] to [Folder View(MP4)] or [AVCHD View] according to the file format.

MENU button →  1 → **[Still/Movie Select]** → **Select the desired mode**

Deleting images

Prior to deleting the image, be sure to make a copy or decide whether you no longer wish to keep the image or not. Make a copy of any images you may want to keep before deleting them from the camera

1 Display the image you want to delete and press the  button.

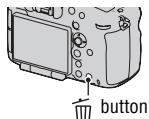

2 Select [Delete] with **▲** on the multi-selector, then press the center of the multi-selector.

Note

- Protected images cannot be deleted.

Selecting a shooting mode

Rotate the mode dial while pressing the mode dial lock button on the center of the mode dial.

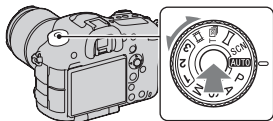

The following shooting modes are provided with the camera:

AUTO (Auto Mode) (69)	Allows you to easily shoot any subject under any conditions because the camera makes appropriate judgements on the situation to adjust the settings.
P (Program Auto) (77)	Allows you to shoot with the exposure adjusted automatically (both the shutter speed and the aperture value). The other settings can be adjusted manually.
A (Aperture Priority) (78)	Allows you to shoot after adjusting the aperture value manually using the front or rear control dial.
S (Shutter Priority) (80)	Allows you to shoot after adjusting the shutter speed manually using the front or rear control dial.
M (Manual Exposure) (82)	Allows you to shoot after adjusting the exposure manually (both the shutter speed and the aperture value) using the front or rear control dial.
1/2/3 (190)	Calls up setting pre-registered in [Memory] in the Still shooting menu.
SCN (Scene Selection) (71)	Allows you to easily shoot any subject under any conditions as the camera makes appropriate settings automatically.
(Sweep Panorama) (73)	Allows you to shoot panoramic images by combining multiple images.
T [00] (Tele-zoom Cont. Priority AE) (76)	Allows continuous shooting while the shutter button is fully depressed. The camera records the images continuously at a maximum of about 10 or 8 images per second.
(Movie) (65, 152)	Allows you to shoot movies with the exposure adjusted manually (both the shutter speed and the aperture value).

- Press the Fn button when you want to change the function of the selected mode (pages 31, 34).

Selecting the desired mode by rotating the mode dial

When you rotate the mode dial, you can display an explanation of the shooting mode and change the function of the selected mode.

1 MENU button →  1 → [Mode Dial Guide] → [On]

2 Select the desired shooting mode with the mode dial.

An explanation of the selected mode is displayed.

3 Press the center of the multi-selector.



4 Select the desired mode with ▲/▼ on the multi-selector.

AUTO Auto Mode

1 Set the mode dial to **AUTO** (Auto Mode) (page 68).

- To change the mode, press the Fn button, then select another mode.

2 Point the camera towards the subject, then adjust the focus and shoot the subject.

 (Intelligent Auto)	The camera makes appropriate judgement on the situation to adjust the settings.
 (Superior Auto)	The camera recognizes and evaluates the shooting condition, and appropriate settings are set automatically. The camera saves 1 appropriate image by combining or separating images, as necessary.

Scene recognition

When the camera recognizes the subject and adjusts itself for shooting conditions, the following information appears on the screen: icon for recognized scene, the number of images to be shot. In Superior Auto mode, the appropriate shooting function for the scene type recognized is also indicated.

Scene recognized by the camera: 🌙 (Night Scene), 🙌 (Hand-held Twilight), 🏔️ (Landscape), 📷 (Backlight Portrait), 👤 (Portrait), 📵 (Tripod Night Scene), 📷 (Backlight), 🌸 (Macro), 🌙 (Night Portrait), 🎯 (Spotlight), 📷 (Low Brightness), 🍼 (Baby)

Shooting function: Cont. Shooting, Slow Sync., Auto HDR, Daylight Sync., Slow Shutter, Hand-held Twilight

Icon for recognized scene

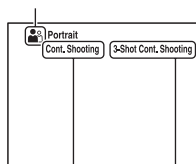

Shooting function

Number of images to be shot

To set the continuous shooting in Superior Auto mode

MENU button → ⚙️ 1 → [S. Auto Cont. Shooting] → Select the desired setting

To select the storage method to be used for recorded images in Superior Auto mode

In continuous shooting, you can select a storage method that allows the camera either to store 1 appropriate image from among the continuously shot images or store all the images.

MENU button → ⚙️ 1 → [S. Auto Image Extract.] → Select the desired setting

Notes

- Even when you set [S. Auto Image Extract.] to [Off] with [Hand-held Twilight] selected from recognized scene mode, 1 combined image is saved.
- When [Quality] is set to [RAW] or [RAW & JPEG], performance will be affected.

SCN Scene Selection







This mode is suitable for





- Shooting with preset settings according to the scene

1 Set the mode dial to SCN (Scene Selection) (page 68).

- To change the scene, press the Fn button, then select another scene.

2 Adjust the focus and shoot the subject.

 (Portrait)	<p>Blurs away backgrounds and sharpens the subject. Expresses skin tones softly.</p> <ul style="list-style-type: none"> • To blur the background more, set the lens to the telephoto position. • You can shoot a vivid image by focusing on the eye that is closer to the lens. • Use the lens hood to shoot backlit subjects. • Use the red-eye reduction function if the eyes of your subject turn red from the flash (page 40). 	
 (Sports Action)	<p>Shoots a moving subject at a fast shutter speed so that the subject looks as if it is standing still. The camera shoots images continuously while the shutter button is pressed.</p> <ul style="list-style-type: none"> • Press and hold the shutter button halfway down until the right moment. 	
 (Macro)	<p>Shoots close-ups of the subjects such as flowers, foods.</p> <ul style="list-style-type: none"> • You can shoot a closer subject using a macro lens (sold separately). • Set the flash mode to [Flash Off] when you shoot a subject within 1 m (3.3 feet). • When shooting in macro mode, the SteadyShot function will not be fully effective. Use a tripod to achieve better results. • The shortest focal distance does not change. 	

<p>▲ (Landscape)</p>	<p>Shoots the entire range of scenery in sharp focus with vivid colors.</p> <ul style="list-style-type: none"> • To accentuate the openness of the scenery, set the lens to wide angle. 	
<p>☉ (Sunset)</p>	<p>Shoots the red of the sunrise or sunset beautifully.</p>	
<p>☾ (Night Scene)</p>	<p>Shoots night scenes at a distance without losing the dark atmosphere of the surroundings.</p> <ul style="list-style-type: none"> • The shutter speed is slower, so using a tripod is recommended. • The picture may not be taken properly when shooting a night scene in total darkness. 	
<p>👤 (Hand-held Twilight)</p>	<p>Shoots night scenes with less noise and blur without using a tripod. A burst of shots are taken, and image processing is applied to reduce subject blur, camera shake, and noise.</p> <ul style="list-style-type: none"> • Reducing blur is less effective even in [Hand-held Twilight] when shooting: <ul style="list-style-type: none"> – Subjects with erratic movement – Subjects too close to the camera – Subjects with a repeating pattern such as tiles, and subjects with little contrast such as sky, sandy beach, or lawn – Subjects with constant change such as waves or water falls • In the case of [Hand-held Twilight], block noise may occur when using a light source that flickers, such as fluorescent lighting. 	
<p>👤 (Night Portrait)</p>	<p>Shoots portraits in night scenes. Attach and fire the flash.</p> <ul style="list-style-type: none"> • The shutter speed is slower, so using a tripod is recommended. 	

Shooting technique

- When you want finer images, set the mode dial to P, A, S, or M and use the creative style function (page 130). In such cases, you can adjust the exposure, ISO, etc.

Notes

- Since the camera judges the settings automatically, many features will be unavailable, such as exposure compensation, ISO setting.
- The flash is set to [Autoflash] or [Flash Off] for each Scene Selection mode. You can change these settings (pages 115, 119).

☒ Sweep Panorama**This mode is suitable for**

- Shooting expansive scenery, or high-rise buildings with dynamic composition.

- 1 Set the mode dial to ☒ (Sweep Panorama).**
- 2 Point the camera at the subject for which you want to adjust the brightness and focus, and press the shutter button halfway down.**
- 3 Point the camera at the edge of the composition, while pressing the shutter button halfway down.**

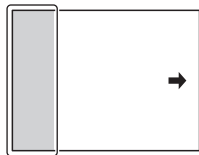

This part will not be taken

- 4 Press the shutter button fully down.**

5 Pan or tilt the camera to the end, following the guidance on the screen.

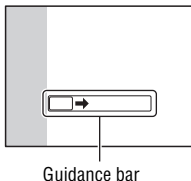

Notes

- If you cannot pan or tilt the camera across the entire subject within the given time, a gray area occurs in the composed image. If this happens, move the camera fast to record a full panoramic image.
- Since several images are stitched together, the stitched part will not be recorded smoothly. While shooting, do not tilt the camera back and forth or right and left while moving the camera across the scene.
- Under low light conditions, panoramic images may be blurred or not be recorded.
- Under lights that flicker such as fluorescent light, the brightness or color of the combined image is not always the same.
- When the panoramic shot overall and the angle in which you fixed the focus and exposure with AE/AF lock are extremely different in brightness, color and focus, the shooting will not be successful. If this happens, change the lock angle and shoot again.
- Sweep Panorama recording is not suitable when shooting:
 - Moving subjects.
 - Subjects too close to the camera.
 - Subjects with a repeating pattern such as tiles, and subjects with little contrast such as sky, sandy beach, or lawn.
 - Subjects with constant change such as waves or water falls.
 - Subjects with the sun or electric lights, etc. that are much brighter than surroundings.
- Sweep Panorama recording may be discontinued in the following situations:
 - You pan or tilt the camera too fast or too slow.
 - There is too much camera shake.
- The camera continues shooting in Sweep Panorama recording, and the shutter keeps clicking until the end of the shooting.
- [Auto Port. Framing] and the zoom feature of the camera cannot be used.

Tips for Sweep Panorama shooting

Pan or tilt the camera in an arc with a constant velocity and in the same direction as the indication on the screen. [Sweep Panorama] is better suited for still subjects, rather than moving ones.

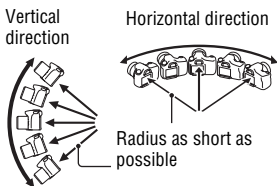

- In Sweep Panorama, it is recommended that you use a wide-angle lens.
- When you use a lens that has a long focal length, pan or tilt the camera more slowly than when you use a wide-angle lens.
- Determine the scene and press the shutter button halfway, so that you can lock the focus, exposure, and white balance.
- If greatly varied shapes or scenery are concentrated along a screen edge, the image composition may fail. In such cases, adjust the frame composition so that the section is in the center of the image, then shoot again.

To change the image size

You can select the image size: MENU button → 1 → [Panorama: Size].

To set the pan or tilt direction

You can set the direction in which to pan or tilt the camera.

MENU button → 1 → [Panorama: Direction] → Select the desired setting

To scroll panoramic images (Scroll Playback)

Select a panoramic image, then press the center of the multi-selector.

- Pressing it again pauses the playback. You can scroll a panoramic image by pressing ▲/▼/◀/▶ during pause.

Tele-zoom Cont. Priority AE

You can record images in high-speed continuous shooting by capturing the narrow center area of an image.

This mode is suitable for



- Shooting a fast-moving subject continuously to capture a moment.
- Shooting a child's expressions, changing continuously from moment to moment.

1 Set the mode dial to (Tele-zoom Cont. Priority AE) (page 68).

- To change the mode, press the Fn button, then select another mode.

2 Adjust the focus and shoot the subjects.

- The camera continues to shoot while the shutter button is pressed fully down.

 (Tele-zoom Cont. Priority AE)	Records the images continuously at a maximum of about 10 images per second with approx. $\times 2.3$ zooming at full-frame shooting, or with approx. $\times 1.5$ zooming at APS-C size shooting.
 (Tele-zoom Cont. Priority AE)	Records the images continuously at a maximum of about 8 images per second with approx. $\times 1.5$ zooming at full-frame shooting. Records the images with the full angle of view at APS-C size shooting.

Shooting techniques

- When [Focus Mode] is set to other than [Single-shot AF], the aperture value is set to F3.5 (when the maximum aperture value of the lens is larger than F3.5, it is set to the maximum aperture value). However, the ISO sensitivity can be adjusted. The focus and the exposure continue to be adjusted during shooting.

- In manual focus mode or when [Focus Mode] is set to [Single-shot AF], you can adjust the ISO sensitivity and the aperture. When [Single-shot AF] is selected, the focus is fixed at the first image.

Notes

- When the zoom scale is $\times 2.3$, the image size is set to S size and when the zoom scale is $\times 1.5$, the image size can be set to M or S size.
- The shutter speed is slower, depending on the ISO or aperture setting. As a result, the speed of continuous shooting may be slower.
- The Face Detection function is turned off.
- When [Auto HDR] is selected, the DRO process is performed temporarily according to the DRO setting.
- You cannot set [Quality] to [RAW] or [RAW & JPEG] when T_Ⓜ is selected.

P Program Auto

This mode is suitable for

- Using the automatic exposure, while keeping the custom settings for ISO sensitivity, Creative Style, D-Range optimizer, etc.

1 Set the mode dial to P.

2 Set the shooting functions to your desired settings (pages 91 to 151).

3 Adjust the focus and shoot the subject.

Program Shift

You can temporarily change the shutter speed and aperture value combination with the correct exposure determined by the camera maintained.

Rotate the front or rear control dial to select your desired combination while the focus is achieved.

The exposure mode indication changes to “P*.”

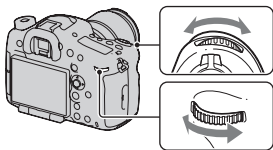

A Aperture Priority

This mode is suitable for

- Putting the subject in sharp focus and blur everything in front of and beyond the subject. Opening the aperture narrows the range that is in focus. (Depth of field becomes shallower.)
- Shooting the depth of the scenery. Narrowing down the aperture widens the range that is in focus. (Depth of field becomes deeper.)

1 Set the mode dial to A.

2 Select the aperture value (F-number) with the front or rear control dial.

- Smaller F-number: The foreground and background of the subject are blurred.
Larger F-number: The subject and its foreground and background are all in focus.
- You cannot check the blurring of an image on the LCD screen or in the viewfinder. Check the recorded image and adjust the aperture.
- When the camera judges that the proper exposure is not obtained with the selected aperture value, the shutter speed flashes. In such cases, adjust the aperture again.

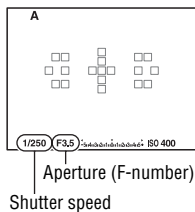
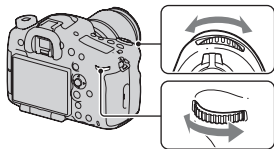

3 Adjust the focus and shoot the subject.

The shutter speed is automatically adjusted to obtain correct exposure.

Shooting techniques

- The shutter speed may become slower depending on the aperture value. When the shutter speed is slower, use a tripod.
- To blur the background more, use a telephoto lens or a lens that is equipped with a smaller aperture value (bright lens).
- You can check the approximate blurring of the image before recording using the preview button.

To check blurring of the background (Preview button)

The LCD screen and the viewfinder shows an image captured with the widest aperture. The change in aperture affects the sharpness of the subject image, creating a discrepancy between the sharpness of the image before shooting and that of the actual image.



Preview button

While you are pressing the preview button, you can see the image with the aperture used in the actual shot so that you can check the approximate sharpness of the subject before shooting.

- Press the preview button after you adjust the focus.
- You can adjust the aperture in preview mode.

2 preview modes are provided with the camera:

[Shot. Result Preview]: The effect of DRO or the shutter speed value is also reflected.

[Aperture Preview] (default setting): Only the aperture is reflected.

MENU button → 4 → [Preview Button] → Select the desired setting (You can also set the function using [Func. of AEL button]/[ISO Button]/[AF/MF button]/[Custom button])

Note

- The preview image may be darker, depending on the shutter speed value. However, you can record images in accordance with the brightness you have set.

S Shutter Priority

This mode is suitable for

- Shooting a moving subject at a moment in time. Use a faster shutter speed to crisply shoot an instant of the movement.
- Tracing the movement to express the dynamism and flow. Use a slower shutter speed to shoot a trailing image of the moving subject.

1 Set the mode dial to S.

2 Select the shutter speed with the front or rear control dial.

- When the camera judges that the proper exposure is not obtained with the selected shutter speed, the aperture value flashes. In such cases, adjust the shutter speed again.

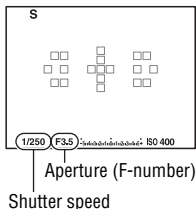
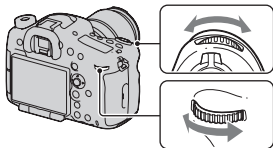

3 Adjust the focus and shoot the subject.

The aperture is automatically adjusted to obtain correct exposure.

Shooting techniques

- When the shutter speed is slower, use a tripod.
- When shooting an indoor sport, select a higher ISO sensitivity.

Notes

- The  (Camera shake warning) indicator does not appear in Shutter Priority mode.
- The higher the ISO sensitivity, the more conspicuous the noise.
- When the shutter speed is 1 second or longer, noise reduction (Long Exposure NR) will be done for the same amount of time that the shutter was open after shooting. You cannot do any further shooting during the reduction.

M Manual Exposure

This mode is suitable for

- Shooting with the desired exposure setting by adjusting both the shutter speed and aperture.

1 Set the mode dial to M.

2 Rotate the front control dial to adjust the shutter speed, and rotate the rear control dial to adjust the aperture.

- This camera allows you to set the ISO sensitivity to [AUTO] in manual exposure mode. When the ISO sensitivity is set to [AUTO], the ISO sensitivity is adjusted to obtain the correct exposure, according to the shutter speed and aperture value combination.
- When the ISO sensitivity is set to [AUTO] and the camera judges that the proper exposure has not been obtained with the selected value, the ISO sensitivity flashes. In such cases, adjust the shutter speed or aperture again.

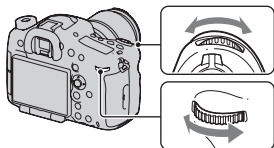

ISO sensitivity

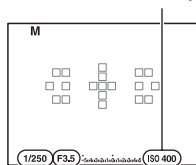

Aperture (F-number)

Shutter speed

3 Shoot the image after the exposure is set.

- When the ISO sensitivity is set to other than [AUTO], check the exposure value using Metered Manual*.

Toward +: Images become brighter.

Toward -: Images become darker.

- * When the camera is in M mode, it will show an under or over compensation value based on the correct exposure. It is displayed as a number on the LCD screen, and it is displayed on the EV scale in the viewfinder.

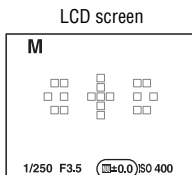

Metered Manual

The screen in the viewfinder



Metered Manual

Note

- The  (Camera shake warning) indicator does not appear in manual exposure mode.

Manual shift

You can change the shutter speed and aperture value combination without changing the exposure you set.

Rotate the front or rear control dial while pressing the AEL button to select the shutter speed and aperture value combination.

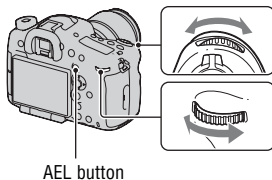

M BULB

This mode is suitable for

- Shooting trails of light, such as fireworks.
- Shooting trails of stars.

1 Set the mode dial to M.

2 Rotate the front control dial to the left until [BULB] appears.

- When the ISO sensitivity is set to [AUTO], selecting [BULB] turns the ISO sensitivity to [100].

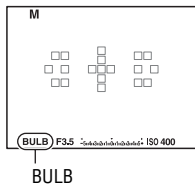
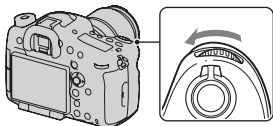

3 Rotate the rear control dial to adjust the aperture (F-number).

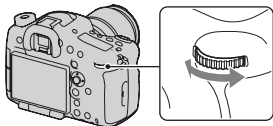

4 Press the shutter button halfway down to adjust the focus.

5 Press and hold the shutter button for the duration of the shooting.

As long as the shutter button is pressed, the shutter remains open.

Shooting techniques

- Use a tripod.
- Set the focus to infinity in manual focus mode when shooting fireworks, etc. When the infinity position of the lens is not known, first adjust the focus on fireworks that is set off in the same general area, then shoot them.
- Use the Wireless Remote Commander (sold separately) (page 114). Pressing the SHUTTER button on the Wireless Remote Commander triggers BULB shooting and pressing it again stops BULB shooting. You do not need to press and hold the SHUTTER button on the Wireless Remote Commander.
- If you use a Remote Commander (sold separately) that is equipped with a shutter button lock function, you can leave the shutter open using the Remote Commander.

Notes

- When using a tripod, turn off the SteadyShot function (page 60).
- The longer the exposure time, the more conspicuous the noise on the image.
- After shooting, noise reduction (Long Exposure NR) will be done for the same amount of time that the shutter was open. You cannot do any further shooting during the reduction. To prioritize the timing of the shot rather than the image quality, set [Long Exposure NR] to [Off] (page 150).
- When the Smile Shutter or Auto HDR function is activated, or when [Picture Effect] is set to [HDR Painting] or [Rich-tone Mono.], you cannot set the shutter speed to [BULB].
- If the Smile Shutter, Auto HDR function, or the [HDR Painting] or [Rich-tone Mono.] setting of [Picture Effect] is used with the shutter speed set to [BULB], the shutter speed is temporarily set to 30 seconds.
- It is recommended that you start BULB shooting after the temperature of the camera drops to prevent the quality of the image from deteriorating.

Functions available for each shooting mode

The functions you can use depend on the selected shooting mode.

In the table below, ✓ indicates the function available. – indicates the function not available.

The functions you cannot use are displayed in gray on the screen.

Shoot Mode		Exposure Comp. (106)	Self-timer (111)	Cont. Shooting (111)	Face Detection (141)	Smile Shutter (145)	Auto Port. Framing (143)
iA / iA+ (69)		–	✓	✓	✓	✓	✓
SCN (71)		–	✓	–	✓	✓	✓
		–	✓	✓	✓	✓	–
		–	✓	–	✓	✓	✓
		–	✓	–	✓	✓	✓
		–	✓	–	✓	✓	✓
		–	✓	–	✓	✓	✓
		–	–	–	✓	–	–
		–	✓	–	✓	✓	✓
(73)	✓	–	–	–	–	–	
Tv / Tv (76)	✓	–	–	–	–	–	
P (77)	✓	✓	✓	✓	✓	✓	
A (78)	✓	✓	✓	✓	✓	✓	
S (80)	✓	✓	✓	✓	✓	✓	
M (82)	–*	✓	✓	✓	✓	✓	
(65, 152)	✓*	✓	✓	✓	✓	–	

* When the exposure mode is set to M, the exposure can be compensated only when the ISO sensitivity is set to [AUTO].

Switching the recording information display (DISP)

Each time you press the DISP button, the recording information display changes as follows in the default settings.

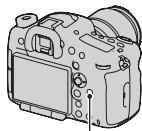

DISP button

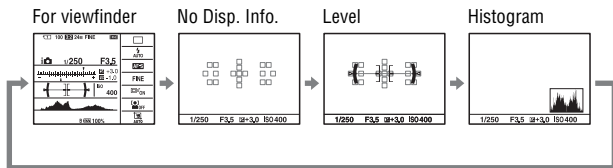

- You can display all the information on the screen or the Graphic Display that shows the shutter speed and aperture value as graphs.

Selecting the screen mode

You can select the desired screen mode. When you switch the screen by pressing the DISP button, only selected screens are displayed. You can set the available screens to be displayed on the LCD screen and the viewfinder separately.

1 MENU button → 2 → [DISP Button(Monitor)] or [DISP Button(Finder)]

2 Select the desired display with /// on the multi-selector, then press the center of the multi-selector.

3 Press the MENU button.

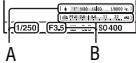
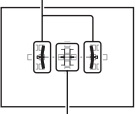
Graphic Display	The Graphic Display shows the shutter speed and aperture value as graphs, and clearly illustrates how the exposure works. The pointers on the shutter speed indicator (A) and aperture indicator (B) indicate the current value.	 <p>The diagram shows a digital display with two horizontal scales. The top scale is for shutter speed, with values 1/250, 1/500, 1/1000, 1/2000, 1/4000, and 1/8000. The bottom scale is for aperture, with values 1.8, 2.8, 4.0, 5.6, 8.0, 11.2, and 16.0. A pointer labeled 'A' points to 1/250 on the shutter speed scale, and a pointer labeled 'B' points to F3.5 on the aperture scale.</p>
Display All Info.	Displays all the information on the screen.	
No Disp. Info.	Does not display the information on the screen.	
Level	<p>The digital level gauge indicates whether the camera is level in both the horizontal and front-back directions. When the camera is level in one direction, the indicator turns to green.</p> <ul style="list-style-type: none"> • The error of the digital level gauge is larger if you tilt the camera too far forward or backward. • A tilt of $\pm 1^\circ$ may be indicated even if the camera is almost level. 	<p>Horizontal direction</p>  <p>Front-back direction</p> <p>The diagram shows a digital level gauge with two vertical scales. The left scale is labeled 'Horizontal direction' and the right scale is labeled 'Front-back direction'. Each scale has a central indicator that can turn green when level.</p>
Histogram	Displays a histogram (page 89).	
For viewfinder*	You can set the status of the LCD screen to one suitable for used with the viewfinder (page 25).	

* This option can be set only when [DISP Button(Monitor)] is selected.

Histogram

The histogram displays the luminance distribution that shows how many pixels of a particular brightness exist in the picture.

The exposure compensation will change the histogram accordingly.

Both ends of the histogram show a high-key or low-key portion. You cannot restore these area with a computer later. Adjust the exposure if necessary and shoot again.

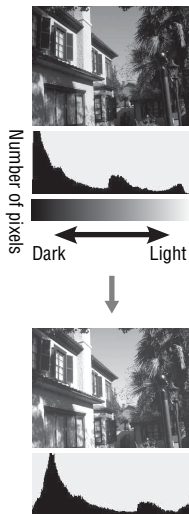

Notes

- The histogram does not indicate the final recorded image. It indicates the condition of the image just monitored on the screen. The histogram will differ based on aperture setting, etc.
- The histogram differs between shooting and playback in the following situations:
 - When firing the flash.
 - When the subject has low intensity, such as night scenery.

Monitoring the subject through the lens without effects displayed

You can monitor the subject through the lens without effects, such as the exposure compensation, white balance, Creative Style, Picture Effect etc., displayed.

MENU button → ⚙ 3 → [Live View Display] → [Setting Effect OFF]

- When [Setting Effect OFF] is selected, the Live View image in M mode is always displayed with the appropriate brightness.

Note

- [Setting Effect OFF] cannot be selected when the exposure mode is set to Auto Mode, Sweep Panorama, Movie or Scene Selection.

Adjusting the focus

There are 2 methods for adjusting the focus: autofocus and manual focus. Depending on the lens, the method for switching between the auto focus and manual focus is different.

The type of lens	The switch to be used	To switch to auto focus	To switch to manual focus
The lens is equipped with a focus mode switch	Lens	Set the focus mode switch on the lens to AF. (Set [Focus Mode] on the camera to other than [Manual Focus].)	Set the focus mode switch on the lens to MF.*
The lens is not equipped with a focus mode switch	Camera	Set [Focus Mode] on the camera to other than [Manual Focus].	Set [Focus Mode] on the camera to [Manual Focus].

* When SSM lenses or SAM lenses compatible with DMF are used, you can change the focus mode from the camera, even if the focus mode switch on the lens is set to AF.

For details on lenses compatible with [Depth Map Assist Continuous AF] and the assist area of the AF Range Control feature, visit the Sony web site in your area, or consult your Sony dealer or local authorized Sony service facility.

Autofocus

1 If the lens is equipped with the focus mode switch, set it to AF.

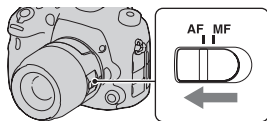

2 Fn button → **AF-S** (Focus Mode) → other than **DMF** (DMF) or **MF** (Manual Focus)

3 Press the shutter button halfway down to check the focus and shoot the image.

- When the focus is confirmed, the focus indicator changes to ● or (●) (page 93).
- The AF area where the focus has been confirmed turns green.

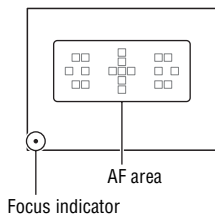

AF-S (Single-shot AF)	The camera focuses and the focus is locked when you press the shutter button halfway down.
AF-A (Automatic AF)	The Focus Mode is switched between Single-shot AF and Continuous AF according to the movement of the subject. When you press and hold the shutter button halfway down, if the subject is motionless, the focus is locked and if the subject is in motion, the camera continues to focus.
AF-C (Continuous AF)	The camera continues to focus while the shutter button is pressed and held halfway down. <ul style="list-style-type: none"> • The audio signals will not sound when the subject is in focus. • Focus-lock cannot be used.
AF-D (Depth Map Assist Continuous AF)	In addition to the Continuous AF function, the camera continues to focus on a subject using the assist area. This option can be selected only when a compatible lens is attached. <ul style="list-style-type: none"> • The AF assist function works after the camera focuses on a subject using the 19 AF areas. You cannot use only the assist area to focus.

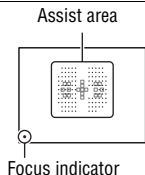

Shooting techniques

- Use [Single-shot AF] when the subject is motionless.
- Use [Continuous AF] or [Depth Map Assist Continuous AF] when the subject is in motion.
- When you want to focus on a subject that moves from side to side and/or up and down among the 19 AF areas, use [Depth Map Assist Continuous AF].

- To select the AF area used for focusing, set up [AF area] (page 95).
- To change the focusing speed, set up [AF drive speed] (page 38).

Notes

- While the camera is focusing automatically, some lenses do not allow you to touch the rotating focusing ring.
- The assist area of the [Depth Map Assist Continuous AF] function may not work properly in the following cases:
 - Under insufficient light.
 - When the drive mode is set to Hi of [Cont. Shooting] or bracket.
 - When the exposure mode is set to Tele-zoom Continuous Priority AE or [Sports Action] in Scene Selection.

Focus indicator

Focus indicator	Status
● lit	Focus locked. Ready to shoot.
⦿ lit	Focus is confirmed. Focal point moves following a moving subject. Ready to shoot.
⦿ lit	Still focusing. You cannot release the shutter.
● flashing	Cannot focus. The shutter is locked.

Subjects that may require special focusing

Using the autofocus, it is hard to focus on the following subjects. In such cases, use the focus lock shooting feature (page 94) or manual focus (page 101).

- A subject that is low in contrast, such as blue sky or a white wall.
- Two subjects at different distances overlapping in the AF area.
- A subject that is composed of repeating patterns, such as the facade of a building.
- A subject that is very bright or glittering, such as the sun, the body of an automobile, or the surface of water.
- Ambient light is not sufficient.

To measure the exact distance to the subject

The \oplus mark located on the top of the camera shows the location of the image sensor*. When you measure the exact distance between the camera and the subject, refer to the position of the horizontal line.

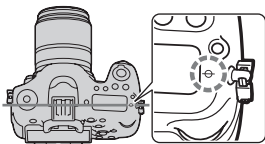

* The image sensor is the part of the camera that converts the light to an electric signal.

Note

- If the subject is closer than the minimum shooting distance of the attached lens, the focus cannot be confirmed. Make sure you put enough distance between the subject and the camera.

Focus-lock

1 Place the subject within the AF area and press the shutter button halfway down.

The focus is locked.

- Set [Focus Mode] to [Single-shot AF].



2 Keep the shutter button halfway down, and put the subject back in the original position to re-compose the shot.



3 Press the shutter button fully down to take the picture.

AF area

Select the desired AF area to suit the shooting conditions or your preference. The AF area where the focus has been confirmed turns green and the other AF areas disappear.

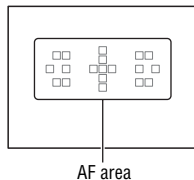

Fn button → [] (AF area) → Select the desired setting

[] (Wide)	The camera determines which of the 19 AF areas is used in focusing.
[] (Zone)	Choose the zone for which you want to activate the focus from among left, right, or center zone with the multi-selector. The camera determines which of the AF areas in the selected zone is used in focusing.
[] (Spot)	The camera uses the AF area located in the center area exclusively.
[] (Local)	Choose the area for which you want to activate the focus from among 19 AF areas with the multi-selector.

Notes

- [AF area] is fixed to [Wide] and you cannot select other settings when the exposure mode is set to Auto Mode or Scene Selection, or when the Object Tracking function is being used or the Smile Shutter is activated.
- The AF area may not be illuminated during continuous shooting or when the shutter button is pressed all the way down without pause.
- The camera selects the assist area automatically. Even if you set it to [Local], you cannot select the desired assist area.

Object Tracking

Keeps tracking a moving subject. In the default settings, when [Focus Mode] is set to [Continuous AF] or [Depth Map Assist Continuous AF], [On(Tracking focus w/ shutter)] will function.

1 Set [Focus Mode] to [Continuous AF] or [Depth Map Assist Continuous AF] (page 91).

2 Fn button →  ON (Object Tracking) → [On(Tracking focus w/ shutter)]

3 Press the shutter button halfway down so that the camera automatically locks onto a target and tracks the subject.

The camera continues to focus while the shutter button is pressed and held halfway down. When the focus is achieved, the target frame turns to green.

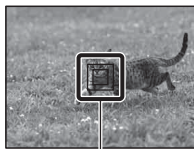

Target frame

4 Press the shutter button to shoot the subject.

When the AF area is set to [Wide], the camera starts tracking the subject from the area that the camera decided automatically.

The camera focus on the subject using all the areas during tracking.



- The camera can start tracking the subject from the selected area when [AF area] is set to [Local] or [Zone].

Shooting techniques

- To capture persons, you can detect and track the person's face using the following settings: [Object Tracking] is set to [On(Tracking focus w/ shutter)], [AF area] is set to [Wide], and [Smile/Face Detect.] is set to [Face Detection On].
- When the subject is small on the Live View screen, you can track the subject certainly by limiting the area used to focus on the subject using the following settings: [Object Tracking] is set to [On(Tracking focus w/ shutter)], [AF area] is set to [Local] or [Zone].

To change the mode

FN button →  **(Object Tracking)** → **[On]** or **[Off]**.

 (On)	Press the center of the multi-selector on the recording information display so that a target frame appears. Align the target frame with the subject to be tracked, and press the center of the multi-selector. The camera starts tracking the subject. When the focus is achieved, the target frame turns to green. To cancel the tracking feature, press the center again.
 (Off)	Deactivates the Object Tracking function.

Notes

- Tracking may be difficult in the following situations:
 - The subject is moving too quickly.
 - The subject is too small, or too large.
 - The contrast between the subject and the background is poor.
 - The subject is under dark lighting.
 - The ambient light changes.
- The Object Tracking function cannot be used when the exposure mode is set to Sweep Panorama, Tele-zoom Continuous Priority AE or [Hand-held Twilight] in Scene Selection, or smart teleconverter is used, the manual focus function is selected.
- The camera stops tracking a subject when the subject moves off of the screen.
- [On(Tracking focus w/ shutter)] can be set only when [Focus Mode] is set to [Continuous AF] or [Depth Map Assist Continuous AF].
- If you start the Object Tracking function, the AF area is set to [Wide] automatically.

To preferentially-track the face

You can select whether to preferentially-track a certain face or not when the camera detects that face during object tracking.

MENU button →  **6** → **[Face Priority Tracking]** → **[On]**

When the face is not visible on the screen, the camera tracks the body, and when the face is visible, the camera tracks the face. If the targeted person disappears from the screen while the camera is tracking, and then returns to the screen, the camera focuses on that face again.

- If the camera tracks a face using the Object Tracking function with Smile Shutter turned on, the face becomes the target of the smile detection feature.

- If you set the detected face as a target, even when [Face Priority Tracking] is set to [Off], the camera tracks the body when the face is not visible. If the targeted person disappears from the screen while the camera is tracking, and then returns to the screen, the camera focuses on that face again.

Restricting the autofocus range (AF Range Control)

You can restrict the autofocus range. This function allows the camera to focus on subject without interference from objects in the back-ground and fore-ground objects.

1 Press the AF RANGE (AF Range Control) button.

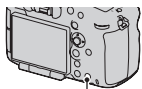

AF RANGE button

2 Set the maximum shooting distance with the front control dial and the minimum shooting distance with the rear control dial.

- The AF area and assist area* that overlap with the subject located within the AF range you set turn to yellow.
- * The assist area appears only when a compatible lens is used.

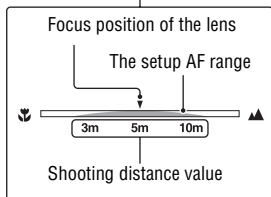
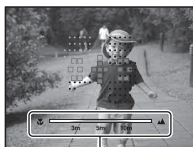

3 Press the AF RANGE button again to lock the distance.

- The limit range indicator remains displayed.
- The AF area and assist area that overlap with the subject located within the AF range you set turn to yellow.

To cancel the AF Range Control function

Press the AF RANGE button again.

Shooting techniques

- Adjust the AF range to position ▼ (the focus position of the lens) within the range after you focus on the subject you want to shoot.
- Adjust the AF range to set the subject to be within or outside the range by checking the yellow points of the AF area and assist area.

Notes

- This function cannot be used with the manual focus or movie recording.
- If you change the lens, the AF range you have set will be reset.
- When a lens equipped with a focus range limiter function is attached, do not use this function with the AF Range Control function on the camera. Use either of the function.
- The shooting distance value is not displayed with a lens that does not have a distance encoder feature.
- The shooting distance value is provided as a guide.
- The AF range and shooting distance value may not be the same as the actual focus position of the lens.
- The actual AF range may not be the same as that of the yellow points of the AF area and assist area.
- If the focus is not achieved, the AF area and assist area may not turn yellow.
- The AF area or assist area may not quickly or easily turn to yellow under insufficient light or when the contrast of the subject is low, such as a solid color flat surface. In such cases, use the contoured part of the subject, etc. to focus on the subject.
- You cannot use this function with the direct manual focus function, except when the lens is equipped with a motor (SSM, SAM lenses*).
 - * Some SAM lenses may not be compatible with the direct manual focus function. Refer to the operating instructions of the lens.
- The initial movement that sets the value to infinity may be performed when you use this function with the AF/MF control function, except when the lens is equipped with a motor (SSM, SAM lenses*).

- * Some SAM lenses may not be compatible with the AF/MF control function. Refer to the operating instructions of the lens.
- For details on lenses compatible with the AF assist function, visit the Sony web site in your area, or consult your Sony dealer or local authorized Sony service facility.

Adjusting the focus except for the shutter button (AF On)

You can adjust the focus using other buttons instead of the shutter button. The setting for autofocus is set to the mode selected with [Focus Mode].

MENU button →  **4** → **Select the desired button*** → **[AF On]**

* Select the setting among [Func. of AEL button], [ISO Button], [AF/MF button], [Custom button], or [Preview Button].

Shooting technique



- If you do not want to use the shutter button to focus, make the following settings in addition to the [AF On] setting.
 - Set [AF w/ shutter] to [Off].
 - Set [AEL w/ shutter] to your preference.

AF illuminator

You can set the AF illuminator to focus on a subject under dark lighting.

MENU button →  **2** → **[AF Illuminator]** → **Select the desired setting**

Notes

- AF illuminator does not operate when [Focus Mode] is set to [Continuous AF] or [Depth Map Assist Continuous AF] or the subject is moving in [Automatic AF]. (The  or  indicator lights.)
- AF illuminator does not operate when [AF area] is set to [Local] or [Zone], and the center area is not selected.
- The AF illuminator may not operate with focal lengths of 300 mm or longer.
- When a flash (sold separately) that is equipped with an AF illuminator is attached, the AF illuminator of the flash is used.
- AF illuminator does not operate when the Smile Shutter function is used.

AF Micro Adj.

You can finely adjust the focus of each lens.

Perform this operation only when needed. Note that you may not be able to properly focus on a subject if you have made a poor adjustment.

MENU button → **3** → **[AF Micro Adj.]** → **[On]** → **[amount]** →
Select the desired value

- The larger the value, the farther the focusing position from the camera; the smaller the value, the nearer the focusing position to the camera.

Notes

- We recommend that you decide the value under actual shooting conditions.
- When you attach a lens that is registered on the camera, the registered value is displayed. If “-” is displayed as the value, then a total of 30 lenses have been registered and no new lens can be registered. When you want to register a new lens, attach a lens for which you can delete its registered value, and set that value to “±0,” or reset the values of all the lenses with [Clear].
- If you perform AF fine adjustment with a lens of other manufacturers, the adjustment values of Sony, Minolta, and Konica Minolta lenses may be affected. Do not use this function with any lens from the manufactures that are not mentioned here.
- You cannot individually perform AF fine adjustment when using the Sony, Minolta, and Konica Minolta lenses that have the same specifications.

Manual focus

When it is difficult to get the proper focus in autofocus mode, you can adjust the focus manually.

- 1 Set the focus mode switch on the lens to MF.**

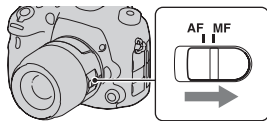

2 If the lens does not have a focus mode switch, Fn button → **AF-S** (Focus Mode) → **MF** (Manual Focus)

- When [Focus Mode] is assigned to the silent multi-controller, you can use the silent multi-controller instead (page 32).

3 Rotate the focusing ring of the lens to achieve a sharp focus.

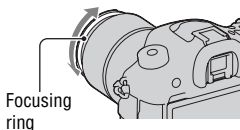

Notes

- When the Wide AF area is used, the center area is used for focusing; when the Zone AF area is used, an object representing the selected area is used; and when the Local AF area is used, an area that is selected with the multi-selector is used.
- When using a tele converter (sold separately), etc., rotation of the focusing ring may not be smooth.
- The correct focus in the viewfinder is not achieved if the diopter is not adjusted properly in viewfinder mode (page 17).
- Make sure to set the focus mode switch on the lens to MF for manual focus. Do not rotate the focusing ring without setting to MF. Rotating the focusing ring forcibly without switching to MF may damage the focusing ring (Except for lenses that are equipped with the Direct manual focus function.).

Enhancing the outline of in-focus ranges (Peaking)

You can enhance the outline of in-focus ranges with a specific color in manual focus. This is convenient to finely focus on a subject in macro shooting or portrait shooting.

You can set the peaking level and the peaking color.

MENU button → **⚙ 3** → **[Peaking Level]** → **Select the desired setting**

Notes

- Since the camera judges that sharp areas are in focus, the peaking level is different, depending on the subject, shooting situation, or on the lens used.

- The outline of in-focus ranges is not enhanced when the camera is connected using an HDMI cable.

To set the color of the peaking function

You can set the color used for the peaking function.

MENU button →  **3** → **[Peaking Color]** → **Select the desired setting**

Note

- This item cannot be set when [Peaking Level] is set to [Off].

Focus Magnifier

You can check the focus by enlarging the image before shooting.

1 MENU button →  **4** → **[Smart Telecon. Button]** → **[Focus Magnifier]**

2 Press the Focus Magnifier button.

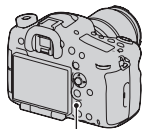

Focus Magnifier button

3 Press the Focus Magnifier button again to enlarge the image and select the portion you want to enlarge with ▲/▼/◀/▶ on the multi-selector.

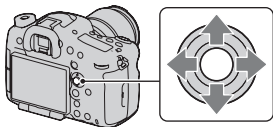

- Each time you press the Focus Magnifier button, the zoom scaling changes as follows:
Full-frame size: Approx. $\times 5.9 \rightarrow$
Approx. $\times 11.7$
APS-C size: Approx. $\times 3.8 \rightarrow$ Approx.
 $\times 7.7$

4 Confirm and adjust the focus.

- Rotate the focusing ring to adjust the focus in manual focus mode.
- If you press the center of the multi-selector, the enlarged portion returns to the center.
- The Focus Magnifier function is canceled if you press the shutter button halfway down.

5 Press the shutter button fully down to shoot the image.

- You can record images when an image is enlarged, however the recorded image is for full display.
- The Focus Magnifier function will be released after shooting.

Direct manual focus (DMF)

You can make fine adjustments after adjusting the focus in auto focus (Direct manual focus).

You can quickly focus on a subject rather than using the manual focus from the beginning. This is convenient in cases such as macro shooting.

1 Fn button \rightarrow **AF-S** (Focus Mode) \rightarrow **DMF** (DMF)

2 Press the shutter button halfway down to lock the focus.

3 Turn the focusing ring to fine-tune the focus while pressing the shutter button halfway down.

Note

- Some SAM lenses are not compatible with the Direct manual focus function. Refer to the operating instructions of your lens to find out if your lens is compatible with it.

The Direct manual focus function on the lens

When the lens is equipped with the Direct manual focus function and the focus mode is set to [Single-shot AF] or [Automatic AF], you can finely adjust the focus with the focusing ring after focus is lock (For example, the DT 16-50mm F2.8 SSM).

AF/MF control

You can switch between auto focus and manual focus without changing the camera composition (AF/MF control).

Press the AF/MF button.

In auto focus mode: The focus mode is switched temporarily to the manual focus. Press and hold the AF/MF button and adjust the focus by rotating the focusing ring.

In manual focus mode: The focus mode is switched temporarily to the auto focus and the focus is locked.

- You can maintain the selected mode without pressing and holding the AF/MF button when [AF/MF button] is set in the  Custom menu (page 176).

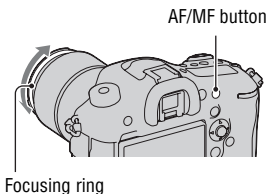

Exposure compensation

Normally, the exposure is selected automatically (Automatic exposure). Based on the exposure acquired by the automatic exposure, you can perform exposure compensation. You can make the entire image brighter by shifting to the + side. The entire image becomes darker when you shift it to the – side (Exposure compensation).

1 Press the button.

 button



2 Adjust the exposure with /▶ on the multi-selector.

Toward + (over): Brightens an image.
Toward – (under): Darkens an image.

- In viewfinder mode, confirm the exposure using the EV scale.

Display of the LCD screen

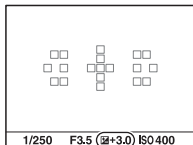

Compensated exposure

Display of the viewfinder



Compensated exposure

3 Adjust the focus and shoot the subject.

Shooting techniques

- Adjust the compensation level by checking the recorded image.
- Using bracket shooting, you can shoot multiple images with the exposure shifted to the plus or minus sides (page 112).

Notes

- This item cannot be set when the exposure mode is set to Auto Mode or Scene Selection.
- When the exposure mode is set to M, the exposure can be compensated only when the ISO sensitivity is set to [AUTO].

To compensate the exposure with the front or rear control dial

You can compensate the exposure with the front control dial or rear control dial without pressing the  button.

MENU button →  **5** → **[Dial exp.comp]** → **Select the desired setting**

Notes

- If you assign the exposure compensation function to the front or rear control dial, the originally-assigned function can be operated with the other control dial.
- When the exposure mode is set to M and the ISO sensitivity is set to [AUTO], [Dial exp.comp] is invalid.

To change the influence of exposure compensation

You can set whether to compensate the exposure within the flash light range or for ambient light only.

MENU button →  **5** → **[Exp.comp.set]** → **Select the desired setting**

AE Lock

When shooting into the sun or by a window, and the exposure may not be appropriate for the subject, use the light meter where the subject is bright enough and lock the exposure before shooting. To reduce the brightness of the subject, point the camera towards a spot that is brighter than the subject and use the light meter to lock the exposure of the entire image. To make the subject brighter, point the camera towards a spot that is darker than the subject and use the light meter to lock the exposure of the entire image. This section describes how to shoot a brighter image of the subject using the  (Spot).

1 Fn button →  (Metering Mode) →  (Spot)

2 Adjust the focus on the portion you want to lock the exposure.

3 Press the AEL button to lock the exposure.

- * (AE lock icon) appears.
- The exposure value is based on the locked exposure in the spot metering circle. That value is displayed on the EV scale.

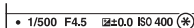
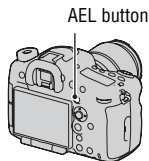



4 While pressing the AEL button, focus on the subject, and shoot the subject.

- If you continue to shoot with the same exposure value, press and hold the AEL button after the shooting. The setting is canceled when the button is released.
-

Metering Mode

Fn button →  **(Metering Mode)** → **Select the desired mode**

 (Multi segment)	This mode measures light on each area after dividing the total area into multiple areas and determines the proper exposure of the entire screen.
 (Center weighted)	While emphasizing the central area of the screen, this mode measures the average brightness of the entire screen.
 (Spot)	This mode measures light only in the spot metering circle located in the center area.

Shooting techniques



- Use [Multi segment] metering for general shooting.
- When there is a high contrast subject in the AF area, measure the light of the subject you want to shoot with the optimal exposure using the spot metering function and take advantage of an AE lock shooting (page 108).

Note

- When the exposure mode is set to Auto Mode or Scene Selection, or when the zoom feature of the camera is used, [Metering Mode] is fixed to [Multi segment] and you cannot select other modes.





/ **Selecting the drive mode**

You can use an appropriate drive mode to suit your purposes, such as single-shot advanced, continuous advanced, or bracket.

 /  **button** → **Select the desired mode**

 /  **button**



 (Single Shooting) (110)	This mode is for normal shooting.
 (Cont. Shooting) (111)	The camera records the images continuously.
 (Self-timer) (111)	The 10-second self-timer is convenient when the photographer wants to be in a photo and the 2-second self-timer is convenient to reduce the camera shake.
BRK C (Bracket: Cont.) (112)	You can shoot the specified number of images, each with different degrees of exposure.
BRK S (Single Bracket) (112)	You can shoot the specified number of images, shot by shot, each with different degrees of exposure.
BRK WB (WB bracket) (113)	Based on the selected white balance, and the color temperature/color filter, 3 images are recorded with the white balance shifted.
BRK DRO (DRO Bracket) (114)	You can shoot 3 images with the value of D-Range Optimizer shifted.
 (Remote Cdr.) (114)	You can shoot still images using the SHUTTER or 2SEC (the shutter is released after 2 seconds) buttons on the RMT-DSLR1/RMT-DSLR2 Wireless Remote Commander (sold separately), or shoot movies using the START/STOP button (only provided with the RMT-DSLR2).





Shooting single shot

 /  **(Drive) button** →  **(Single Shooting)**

Note

- When the exposure mode is set to [Sports Action] in Scene Selection, you cannot shoot single shot.

Cont. Shooting

1  /  (Drive) button →  (Cont. Shooting) → Select the desired speed with  /  on the multi-selector

2 Adjust the focus and shoot the subject.

- When you press and hold the shutter button, the recording continues.

Shooting technique

- To shoot continuously faster, set the exposure mode to Tele-zoom Continuous Priority AE (page 76).

Notes

- When  HI is selected, the image recorded between the frames is displayed.
- You cannot shoot continuously when using Scene Selection modes other than [Sports Action].

Self-timer

1  /  (Drive) button →  (Self-timer) → Select the desired setting with  /  on the multi-selector

- The number right next to  is the number of seconds that is currently selected.

2 Adjust the focus and shoot the subject.

- When the self-timer is activated, audio signals and the self-timer lamp indicate the condition. The self-timer lamp flashes quickly and the audio signal sounds quickly right before the shooting.

To cancel the self-timer

Press the  /  (Drive) button.

Bracket: Cont./Single Bracket



Base exposure



- direction



+ direction

Bracket shooting allows you to shoot several images, each with different degrees of exposure. Specify the value of deviation (steps) from the base exposure, and the camera shoots 3 or 5 images while automatically shifting the exposure.

1  /  (Drive) button → **BRK C** (Bracket: Cont.) or **BRK S** (Single Bracket) → Select the desired bracket step and the number of images with **◀/▶** on the multi-selector

2 Adjust the focus and shoot the subject.



The base exposure is set at the first shot in the bracket.

- Press and hold the shutter button until recording stops when [Bracket: Cont.] is selected.
- Press the shutter button shot by shot when [Single Bracket] is selected.

Notes

- When the exposure mode is set to M and the ISO sensitivity is set to other than [AUTO], the exposure is shifted by adjusting the shutter speed. When the ISO sensitivity is set to [AUTO], the exposure is shifted by adjusting the ISO sensitivity.
- When you adjust the exposure, the exposure is shifted based on the compensated value.
- The bracket cannot be used when the exposure mode is set to Auto Mode, Sweep Panorama, Tele-zoom Continuous Priority AE, or Scene Selection.
- When the flash is fired, flash bracket, which shifts the amount of flash light, is selected, even if [Bracket: Cont.] is selected. To shoot, press the shutter button shot by shot.

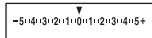
The EV scale in bracket shooting

	Ambient light* bracket 0.3 steps, 3 shots Exposure compensation 0	Flash bracket 0.7 steps, 3 shots Flash compensation -1.0
Viewfinder		
LCD screen (When [DISP Button(Monitor)] is set to [For viewfinder])	 Shown in the top row.	 Shown in the bottom row.

* Ambient light: Any light other than the flash light that shines on the scene for an extended period of time, such as natural light, a light bulb, or a fluorescent light.

- In bracket shooting, the same number of indices as the number of recordable images is displayed on the EV scale.
- When the bracket shooting starts, the indices that indicate already recorded images start to disappear one by one.

WB bracket

1  /  (Drive) button → **BRK** WB (WB bracket) → Select the desired setting with  /  on the multi-selector

- When Lo is selected, it is shifted by 10 MK⁻¹*, and when Hi is selected, it is shifted by 20 MK⁻¹.

2 Adjust the focus and shoot the subject.

* MK⁻¹: a unit to indicate the color conversion quality in color temperature filters (The same value as “Mired.”).

DRO Bracket

1  /  (Drive) button →  **BRK DRO (DRO Bracket)** → **Select the desired setting with  /  on the multi-selector**

- When Lo is selected, the image is recorded with DRO Lv1, Lv2, and Lv3, and when Hi is selected, the image is recorded with DRO Lv1, Lv3, and Lv5.

2 Adjust the focus and shoot the subject.

Remote Cdr.

1  /  (Drive) button →  (Remote Cdr.)

2 Focus on the subject, point the transmitter of the Wireless Remote Commander to the remote sensor, and shoot the image.

Notes

- The RMT-DSLR1 Wireless Remote Commander (sold separately) cannot be used for movie recording. Use the RMT-DSLR2 (sold separately).
- You can check the START/STOP operation of the RMT-DSLR2 by the light of the self-timer lamp on the camera.
- When [MOVIE Button] is set to [Movie Mode Only], the START/STOP button on the Remote Commander can be available only when the mode dial is set to Movie (only for the RMT-DSLR2).
- Refer also to the operating instructions supplied with the Wireless Remote Commander.

Using the flash (sold separately)

In a dark location, using the flash allows you to shoot the subject brightly, and it also helps to prevent camera shake. When shooting into the sun, you can use the flash to shoot a bright image of the backlit subject.

For details on how to use the flash, refer to the operating instructions supplied with the flash.

1 Remove the Shoe Cap and attach the flash (sold separately).

- Firmly push the flash into the Multi interface shoe in the direction of the arrow until it stops. Confirm that it is locked.
- When you use a flash compatible with the Auto-lock Accessory shoe, attach the Shoe adaptor to the camera (page 24).

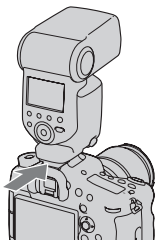

2 Turn the flash on and after the flash charging is completed, shoot the subject.

- ⚡● Flashing: The flash is being charged.
- ⚡● Lit: The flash has been charged.
- When you press the shutter button halfway down under dark lighting in auto focus mode, the AF illuminator of the flash may be emitted.

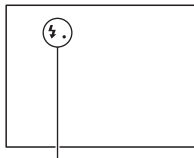





⚡● (Flash charging) indicator

3 Fn button → ⚡ (Flash Mode) → Select the desired setting

- For further information on the flash modes available for each shooting mode, see page 119.

Note

- The lens may block the light of the flash and a shadow may appear on the bottom of the image. Remove the lens hood.

 (Flash Off)	Does not fire.
 (Autoflash)	Fires in dark environments or when shooting towards bright light.
 (Fill-flash)	Fires every time you trigger the shutter.
 (Rear Sync.)	Fires right before the exposure is completed every time you trigger the shutter.
 (Wireless)	Rather than attaching a flash on the camera, you can create more contrast, resulting in a more three-dimensional picture.

Shooting techniques

- When using the flash, shoot the subject at a distance of 1 m (3.3 feet) or greater.
- When shooting indoors or shooting nightscapes, you can use slow sync to shoot a brighter image of people and backgrounds.
- You can use rear sync to shoot a natural image of the trail of a moving subject such as a moving bicycle or a walking person.
- When using the HVL-F60M/HVL-F58AM/HVL-F43AM Flash (sold separately), you can shoot with the High-speed sync feature at any shutter speed. For details, refer to the operating instructions supplied with the flash.

Wireless flash

1 Remove the Shoe Cap and attach the HVL-F60M/HVL-F58AM/HVL-F43AM/HVL-F20AM flash to the camera (page 115).

- When you attach an HVL-F58AM, HVL-F43AM or HVL-F20AM, attach the Shoe adaptor to the camera beforehand (page 24).

2 Set the flash to “wireless controller.”

3 Fn button → (Flash Mode) → (Wireless)

4 Place the flash that has been set to wireless away from the camera.

5 If you perform a test fire of the flash, press the AEL button.

Note

- Change the channel of the flash when another photographer is using a wireless flash nearby and his/her flash light causes your flash to fire. To change the channel of the flash, refer to the operating instructions supplied with it.

Setup of the AEL button

When using a wireless flash, it is recommended that you set [Func. of AEL button] to [AEL hold] in the  Custom menu (page 176).

Wireless flash with lighting ratio control

You can use the wireless lighting ratio control in combination with the multiple flashes. For details, refer to the operating instructions supplied with the flash (HVL-F60M, HVL-F58AM, HVL-F43AM).

Slow Sync

If you use the slow sync shooting feature with a slower shutter speed, you can capture a clear image of both the subject and the background. This is convenient when you shoot a portrait at night with a dark background.

Shoot with the SLOW SYNC button pressed.

The  icon lights up on the screen, indicating that the exposure is locked.

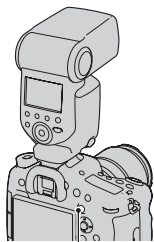

SLOW SYNC button

Notes

- When the exposure mode is set to S or M, slow sync shooting is not available using the SLOW SYNC button.
- When a function other than the AEL function is selected in [Func. of AEL button], slow sync shooting is not available using the SLOW SYNC button. When the AEL function is selected in [ISO Button], [AF/MF button], [Custom button], or [Preview Button], slow sync shooting is available using these buttons.

Using a flash equipped with a flash sync terminal cord

Open the cover of the ⚡ (flash sync) terminal and plug the cord in.

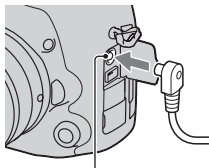

⚡ (flash sync) terminal

- You can use a flash equipped with a flash sync terminal of the opposite polarity.

Notes















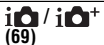

- Select the manual exposure mode (settings other than ISO AUTO are recommended) and set the shutter speed to 1/250 second. If the shutter speed recommended on the flash is slower than that, use the recommended speed or an even slower speed.
- If you cannot confirm your composition in dark situations, change the [Live View Display] setting so that the image is always displayed with the appropriate brightness (page 89).
- Use a flash with a flash sync voltage of 400 V or less.
- Before you connect the flash sync cord to the ⚡ (flash sync) terminal, turn off the power of the connected flash. If the power is on, it may flash when you connect the cord.
- The flash will always be full emission. Flash compensation (page 120) cannot be used.
- Using auto white balance is not recommended. Use custom white balance to gain more precise white balance.
- The flash indicator is not displayed when the ⚡ (flash sync) terminal is plugged in.

Flash modes available

The flash modes you can select depend on the shooting mode and functions selected.

In the table below, ✓ indicates the function selectable. – indicates the function not selectable.

The flash modes you cannot select are displayed in gray on the screen.

Shoot Mode	 (Flash Off)	 (Autoflash)	 (Fill-flash)	 (Rear Sync.)	 (Wireless)	
 (69)	–	✓	✓	–	–	
SCN (71)		–	✓	✓	–	–
		✓	–	✓	–	–
		–	✓	✓	–	–
		✓	–	✓	–	–
		✓	–	✓	–	–
		✓	–	–	–	–
		✓	–	–	–	–
	–	✓	–	–	–	
 (73)	✓	–	–	–	–	
 (76)	–	–	✓	✓	✓	
P (77)	–	–	✓	✓	✓	
A (78)	–	–	✓	✓	✓	
S (80)	–	–	✓	✓	✓	
M (82)	–	–	✓	✓	✓	
 (65, 152)	✓	–	–	–	–	

Flash Compensation

When shooting with the flash, you can adjust the amount of flash light alone, without changing the exposure compensation. You can only change the exposure of a main subject that is within the flash range.

Fn button →  (Flash Comp.) → Select the desired setting

Toward +: Makes the flash level higher.

Toward -: Makes the flash level lower.

Notes

- This item cannot be set when the exposure mode is set to Auto Mode, Sweep Panorama, or Scene Selection.
- The higher flash effect may not be visible due to the limited amount of flash light, if the subject is outside the maximum range of the flash. If the subject is very close, the lower flash effect may not be visible.

Exposure compensation and flash compensation

Exposure compensation changes the shutter speed, aperture, and ISO sensitivity (when [AUTO] is selected) to perform the compensation.

Flash compensation only changes the amount of flash light.

Flash control

MENU button →  **2** → **[Flash control]** → **Select the desired setting**

ADI flash	This method controls the lighting of the flash, factoring in the focus distance information and light metering data from the pre-flash. This method enables an accurate flash compensation with virtually no effect from the reflection off the subject.
Pre-flash TTL	This method controls the amount of flash light depending on the data only from pre-flash light metering. This method is susceptible to the reflection off the subject.

ADI: Advanced Distance Integration

TTL: Through the lens

- When [ADI flash] is selected, using a lens that has a distance encoder feature can provide more accurate flash compensation by utilizing distance information.

Notes

- When the distance between the subject and the flash cannot be determined (wireless flash shooting using a flash, shooting with an off-camera flash using a cable, shooting with a macro twin flash, etc.), the camera automatically selects Pre-flash TTL mode.
- Select [Pre-flash TTL] in the following cases, as the camera cannot perform flash compensations with ADI flash.
 - A wide panel is attached to the HVL-F36AM flash.
 - A diffuser is used for flash shooting.
 - A filter with an exposure factor, such as an ND filter, is used.
 - A close-up lens is used.
- ADI flash is only available in combination with a lens that is provided with a distance encoder. To determine if the lens is equipped with a distance encoder, refer to the operating instructions supplied with the lens.
- This item cannot be set when the exposure mode is set to Sweep Panorama, or [Night Scene]/[Hand-held Twilight] in Scene Selection.

FEL lock

In normal flash shooting, the amount of flash light is automatically adjusted to get the optimum exposure. You can lock the amount of flash light beforehand.

FEL: Flash Exposure Level

- 1 Put the subject for which you want to lock the FEL in the center area of the screen and focus on it.**



- 2 Press the custom button to lock the amount of flash light.**

- The flash pre-fills the flash light.
-  (FEL lock) mark lights.

Custom button

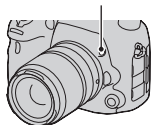

- 3 Recompose the shot and shoot the subject.**

- To cancel the FEL lock function, press the custom button again.

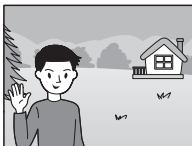

Flashes compatible with the FEL lock function

- The HVL-F60M and HVL-F43AM can be used with the Clip-on LCD monitor, an off-camera using a cable or be used for wireless (controller/remote) shooting.
- The HVL-F58AM and HVL-F20AM can be used with the Clip-on LCD monitor or an off-camera using a cable.

Notes

- This function cannot be set when a flash is not attached.

- An error message appears if you attempt to set a flash not compatible with the FEL lock function.
-  is indicated when you have locked both the AE and FEL.

To change the function of the custom button

You can set the button to hold the locked level while the button is held down ([FEL Lock hold]) or assign another function.

MENU button →  **4** → **[Custom button]** → **Select the desired setting**

Setting ISO

Sensitivity to light is expressed by the ISO number (recommended exposure index). The larger the number, the higher the sensitivity.

1 Press the ISO button to display the ISO screen.

ISO button

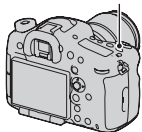

2 Select the desired setting with ▲/▼ on the multi-selector.

- The larger the number, the higher the noise level.
- If you want to select [Multi Frame Noise Reduct.], display the setup screen with ►, and select the desired value with ▲/▼.
- The number changes in increments of 1/3 of a step using the rear control dial as with the multi-selector, and it changes in increments of 1 step using the front control dial.

Notes

- The recordable range of the brightness of a subject (dynamic range) is slightly narrower for areas where ISO is less than 100.
- When the exposure mode is set to Auto Mode, Sweep Panorama, or Scene Selection, ISO is fixed to [AUTO] and you cannot select other ISO numbers.
- When the exposure mode is set to P/A/S/M and ISO is set to [AUTO], ISO is automatically set between ISO 100 and ISO 6400.

To change the automatic adjustment range in [AUTO]

When [AUTO] is selected, press ►, select [ISO AUTO Maximum] or [ISO AUTO Minimum], then select the desired range.

Multi frame noise reduction

The camera automatically shoots multiple images continuously, combines the images, reduces the noise, and records 1 image. In multi frame noise

reduction, you can select larger ISO numbers than the maximum ISO sensitivity.

The image recorded is 1 combined image.

1 Press the ISO button to display the ISO screen.

ISO button

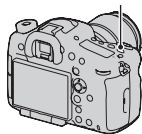



2 Select (Multi Frame Noise Reduct.) with ▲/▼ on the multi-selector.

Notes

- When [Quality] is set to [RAW] or [RAW & JPEG], this function cannot be used.
- The flash, D-Range optimizer, and [Auto HDR] cannot be used.

Compensating for the brightness and contrast automatically (D-Range)



Fn button → ** (DRO/Auto HDR)** → **Select the desired setting**

 (Off)	Disables the DRO/Auto HDR functions.
 (D-Range Opt.)	By dividing the image into small areas, the camera analyses the contrast of light and shadow between the subject and the background, producing the image with the optimal brightness and gradation.
 (Auto HDR)	Shoots 3 images with different exposures, and then overlays the correctly exposed image, the bright areas of an under exposed image and the dark areas of an over exposed image to create an image with rich gradation. 2 images are recorded: an image with the correct exposure and an overlaid image.

D-RangeOptimizer

1 Fn button → ** (DRO/Auto HDR)** → ** (D-Range Opt.)**

2 Select an optimal level with /▶ on the multi-selector.

 (D-Range Optimizer: Auto)	Corrects the brightness automatically.
 (Level)*	Optimizes the gradations of a recorded image in each area of the image. Select the optimal level between Lv1 (weak) and Lv5 (strong).

* Lv_ displayed with **** is the step currently selected.

Notes

- The setting is fixed to [Off] when the exposure mode is set to Sweep Panorama, or when [Multi Frame Noise Reduct.] or [Picture Effect] is used.
- The setting is fixed to [Off] when [Sunset], [Night Scene], [Night Portrait], or [Hand-held Twilight] is selected in Scene Selection. The setting is fixed to [Auto] when other modes are selected in Scene Selection.

- When shooting with the D-Range optimizer, the image may be noisy. Select the proper level by checking the recorded image, especially when you enhance the effect.

Auto HDR

1 Fn button → **D-Range OFF** (DRO/Auto HDR) → **HDR** (Auto HDR)

2 Select an optimal level with ◀/▶ on the multi-selector.

HDR AUTO (Auto HDR: Exposure Diff. Auto)	Corrects the exposure difference automatically.
HDR (Exposure Difference Level)*	Sets the exposure difference, based on the contrast of the subject. Select the optimal level between 1.0Ev (weak) and 6.0Ev (strong). For example: When 2.0Ev is selected, 3 images are overlaid: an image with -1.0Ev, an image with the correct exposure, and an image with +1.0Ev.

*_Ev displayed with **HDR** is the step currently selected.

Shooting technique

- Since the shutter is released 3 times for 1 shot, be careful about the following:
 - Use this function when the subject is motionless or does not blink.
 - Do not recompose.

Notes

- You cannot use this function on RAW images.
- When the exposure mode is set to Auto Mode, Sweep Panorama, Tele-zoom Continuous Priority AE or Scene Selection, or when [Multi Frame Noise Reduct.] is selected, you cannot select [Auto HDR].
- You cannot start the next shoot until the capture process is completed after you shoot.
- You may not obtain a desired effect depending on the luminance difference of a subject and the shooting conditions.
- When the flash is used, this function has little effect.

- When the contrast of the scene is low or when camera shake or subject blur is occurred, you may not obtain good HDR images. If the camera has detected a problem, **HDR**  is displayed on the recorded image to inform you of this situation. Shoot again, as necessary, paying attention to the contrast or blur.

















Setting the image processing

Picture Effect

Select the desired effect filter to achieve more impressive and artistic expression.

Fn button →  **(Picture Effect)** → **Select the desired setting**

- When a mode that has a fine adjustment option is selected, select the desired setting with ◀/▶ on the multi-selector.

 (Off)	Disables the Picture Effect function.
 (Toy Camera)	Creates the look of a Toy Camera photo with shaded corners and pronounced colors. You can set the color tone with ◀/▶.
 (Pop Color)	Creates a vivid look by emphasizing color tones.
  (Posterization)	Creates a high contrast, abstract look by heavily emphasizing primary colors, or in black and white. You can select primary colors or black and white with ◀/▶.
 (Retro Photo)	Creates the look of an aged photo with sepia color tones and faded contrast.
 (Soft High-key)	Creates an image with the indicated atmosphere: bright, transparent, ethereal, tender, soft.
    (Partial Color)	Creates an image which retains 1 specific color, but converts others to black and white. You can select a color with ◀/▶.
 (High Contrast Mono.)	Creates a high-contrast image in black and white.
 (Soft Focus)	Creates an image filled with a soft lighting effect. You can set the intensity of the effect with ◀/▶.
 (HDR Painting)	Creates the look of a painting, enhancing the colors and details. The camera releases the shutter 3 times. You can set the effect intensity with ◀/▶.
 (Rich-tone Mono.)	Creates an image in black and white with rich gradation and reproduction of details. The camera releases the shutter 3 times.
 (Miniature)	Creates an image which enhances the subject vividly, with the background defocused considerably. This effect may often be found in pictures of miniature models. You can select the area to be in focus with ◀/▶. The focus on other areas is greatly reduced.

Notes

- When a zoom feature other than optical zoom is used, the [Toy Camera] and [Miniature] effects are not available.
- When [Partial Color] is selected, images may not retain the selected color, depending on the subject or shooting condition.
- When the exposure mode is set to Auto Mode, Sweep Panorama, or Tele-zoom Continuous Priority AE, or when [Quality] is set to [RAW] or [RAW & JPEG], Picture Effect cannot be used.
- When [HDR Painting], [Miniature], [Rich-tone Mono.] or [Soft Focus] is selected, you cannot confirm the effect before shooting. You cannot also set the drive mode.
- When the contrast of the scene is low or when significant camera shake or subject blur has occurred with [HDR Painting] or [Rich-tone Mono.] selected, you may not obtain good HDR images. If the camera detects such situation, **!** appears on the recorded image to inform you of this situation. Shoot again, as necessary, recomposing or paying attention to the blur.

Creative Style

You can select the style to be used to perform image processing from among 13 styles, and you can also adjust the contrast, saturation, and sharpness for each Creative Style.

You can also adjust the exposure (shutter speed and aperture), unlike Scene Selection where the camera adjusts the exposure.

1 Fn button → **Std.** (Creative Style)

- 13 Creative Styles and 6 style boxes (as **Std.**, the number is displayed on the left of the icon) are displayed. You can register your adjustment in a style box.

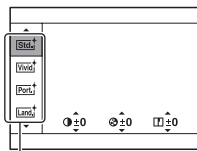

Creative Style/Style box

2 Select the desired Creative Style or style box with ▲/▼ on the multi-selector.



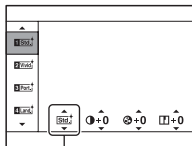



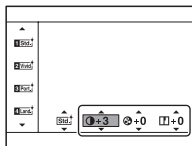

- When selecting a style box, move the cursor to the right with ►, then select the desired Creative Style.
- Using the style box, you can recall the style settings that were registered with finely-controlled settings.









Displayed only when a style box is selected.



3 When you want to adjust (Contrast), (Saturation), or (Sharpness), select the desired item with ◀/▶, then adjust the value with ▲/▼.



 (Standard)	For shooting various scenes with rich gradation and beautiful colors.
 (Vivid)	The saturation and contrast are heightened for shooting striking images of colorful scenes and subjects such as flowers, spring greenery, blue sky, or ocean views.
 (Neutral)	The saturation and sharpness are lowered for capturing images in a quiet tone. This is also suitable for capturing image material to be modified with a computer.
 (Clear)	For capturing images in a clear tone with limpid colors in the highlighted area, suitable for capturing radiant light.
 (Deep)	For capturing images with deep and dense color expressions, suited to capturing the solid presence of the subject.
 (Light)	For capturing images with bright and uncomplicated color expressions, suited to capturing refreshingly light ambience.
 (Portrait)	For shooting the skin color in a soft tone, ideally suited to shooting portraits.
 (Landscape)	The saturation, contrast, and sharpness are heightened for shooting vivid and crisp scenery. Distant landscapes also stand out more.
 (Sunset)	For shooting the beautiful red of the setting sun.

 (Night Scene)	The contrast is attenuated for capturing a nightscape that is more faithful to the real view.
 (Autumn leaves)	For capturing autumn scenes, vividly highlighting the red and yellow of coloring leaves.
 (Black & White)	For shooting images in black and white monotone.
 (Sepia)	For capturing images in sepia monotone.

 (Contrast),  (Saturation), and  (Sharpness) can be adjusted for each style box.

 (Contrast)	The higher the value selected, the more the difference of light and shadow is accentuated, thus making an impact on an image.
 (Saturation)	The higher the value selected, the more vivid the color. When a lower value is selected, the color of the image is restrained and subdued.
 (Sharpness)	Adjusts the sharpness. The higher the value selected, the more the contours are accentuated, and the lower the value selected, the more the contours are softened.

Notes

- When the exposure mode is set to Auto Mode or Scene Selection, or the Picture Effect mode is selected, [Creative Style] is fixed to [Standard] and you cannot select other settings.
- When [Black & White] or [Sepia] is selected, you cannot adjust the saturation.

Adjusting the color tones (White balance)

The color tone of the subject changes depending on the characteristics of the light source. The table below shows how the color tone changes based on various light sources, compared with a subject that appears white under the sunlight.

Weather/lighting	Daylight	Cloudy	Fluorescent	Incandescent
Characteristics of light	White	Bluish	Green-tinged	Reddish

Use this feature when the color tone of the image did not come out as you expected, or when you want to change the color tone on purpose for photographic expression.

Notes

- When the exposure mode is set to Auto Mode or Scene Selection, [White Balance] is fixed to [Auto WB] and you cannot select other modes.
- If the only light source available is a mercury lamp or a sodium lamp, the camera will not be able to acquire the accurate white balance because of the characteristics of the light source. Use the flash in such cases.

WB button → **Select the desired setting**

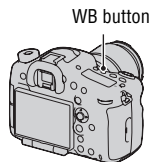

AWB (Auto WB)	The camera automatically detects a light source and adjusts the color tones.
☀ (Daylight)	<p>If you select an option to suit a specific light source, the color tones are adjusted for the light source (preset white balance).</p> <ul style="list-style-type: none"> Press ▶ on the multi-selector so that the fine adjustment screen appears and you can adjust the color tone with ▲/▼/◀/▶, as necessary (page 134).
🏠 (Shade)	
☁ (Cloudy)	
💡 (Incandescent)	
☀⁻¹ (Fluor.: Warm White)	
☀⁰ (Fluor.: Cool White)	
☀⁺¹ (Fluor.: Day White)	
☀⁺² (Fluor.: Daylight)	
⚡ (Flash)	

Shooting technique

- Use the white balance bracket function if you cannot get the desired color in the selected option (page 113).

C.Temp./Filter

You can select the desired color temperature and perform a fine adjustment by combining the color temperature with the color filter.

- WB button** → **☒** (C.Temp./Filter)
→ **▶** on the multi-selector

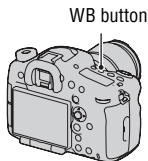

- Set the color temperature with ▲/▼.**

3 Press **▶** to display the fine adjustment screen and compensate the color to your preference with **▲/▼/◀/▶**.

Color Temperature: Fine-tunes color in the B (blue) direction with **◀** and the A (amber) direction with **▶**.

Color Filter: Fine-tunes color in the G (green) direction with **▲** and the M (magenta) direction with **▼**.

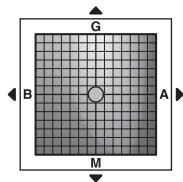

Note

- Since color meters are designed for film cameras, the values differ under fluorescent/sodium lamp/mercury lamps. We recommend that you use the custom white balance or perform a test shooting.

Custom white balance

In a scene where the ambient light consists of multiple types of light source, use of custom white balance is recommended in order to accurately reproduce the whiteness. Up to 3 settings can be registered.

1 WB button → [**WB** SET] → press the center of the multi-selector

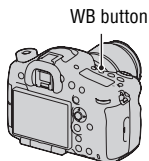

2 Hold the camera so that the white area fully covers the AF area located in the center, and then press the shutter button down.

The shutter clicks and the calibrated values (Color Temperature and Color filter) are displayed.

3 Select a register number with ◀/▶ on the multi-selector, then press the center of the multi-selector.

The monitor returns to the recording information display with the memorized custom white balance setting retained.

- The custom white balance setting registered in this operation is effective until a new setting is registered.

Note

- The message “Custom WB error” indicates that the value is beyond the expected range, when the flash is used on a subject in close proximity or a subject with a bright color is in the frame. If you register this value, the  indicator turns yellow on the recording information display. You can shoot at this point, but it is recommended that you set the white balance again to get a more accurate white balance value.

To recall the custom white balance setting WB button → Select the desired register number

- Press ▶ on the multi-selector to display the fine adjustment screen and compensate the color to your preference.

Note

- If the flash is used when the shutter button is pressed, a custom white balance is registered with the flash light taken into account. Take pictures with the flash in later shootings.

Setting image size

Image Size

MENU button →  1 → [Image Size] → Select the desired size

[Aspect Ratio]: [3:2]

Image size		Usage guidelines
L:24M	6000 × 4000 pixels	For shooting at the highest image quality
M:10M	3936 × 2624 pixels	For prints up to A3+ size
S:4.6M	2640 × 1760 pixels	For prints up to A5 size

[Aspect Ratio]: [16:9]

Image size		Usage guidelines
L:20M	6000 × 3376 pixels	For viewing on a high-definition TV
M:8.7M	3936 × 2216 pixels	
S:3.9M	2640 × 1488 pixels	

[APS-C Size Capture]: [On]

	[Aspect Ratio]: [3:2]		[Aspect Ratio]: [16:9]	
L	L:10M	3936 × 2624 pixels	L:8.7M	3936 × 2216 pixels
M	M:4.6M	2640 × 1760 pixels	M:3.9M	2640 × 1488 pixels
S	S:2.0M	1728 × 1152 pixels	S:1.7M	1728 × 976 pixels

Notes

- When you select a RAW image with [Quality], the image size of the RAW image corresponds to L. This size is not displayed on the screen.
- When a DT lens is attached, the image size used for APS-C is automatically selected.
- The images recorded with [Image Size] set to [S:2.0M] in APS-C size shooting cannot be magnified.

Panorama: Size

You can set the image size of panoramic images. The image size varies depending on the setting of the shooting direction (page 75).

MENU button →  **1** → **[Panorama: Size]** → **Select the desired size**

Standard	[Panorama: Direction] is set to [Up] [Down]: 3872 × 2160 [Panorama: Direction] is set to [Right] [Left]: 8192 × 1856
Wide	[Panorama: Direction] is set to [Up] [Down]: 5536 × 2160 [Panorama: Direction] is set to [Right] [Left]: 12416 × 1856

Setting the aspect ratio and image quality

Aspect Ratio

MENU button →  **1** → **[Aspect Ratio]** → **Select the desired ratio**

3:2	A normal ratio.
16:9	An HDTV ratio.

Note

- This item cannot be set when the exposure mode is set to Sweep Panorama.

Quality

MENU button →  **1** → **[Quality]** → **Select the desired setting**

RAW (RAW)	File format: RAW (Records using the RAW compression format.) This format does not perform any digital processing on the images. Select this format to process images on a computer for professional purposes. <ul style="list-style-type: none">• The image size is fixed to the maximum size. The image size is not displayed on the screen.
RAW+J (RAW & JPEG)	File format: RAW (Records using the RAW compression format.) + JPEG A RAW image and a JPEG image are created at the same time. This is suitable when you need 2 image files, a JPEG for viewing, and a RAW for editing.
X.FINE (Extra fine)	File format: JPEG
FINE (Fine)	The image is compressed in the JPEG format when recorded.
STD (Standard)	The compression rate is higher and the file size is smaller in the following order: [Extra fine], [Fine], and [Standard].

Note

- This item cannot be set when the exposure mode is set to Sweep Panorama.

About RAW images

- You need the “Image Data Converter” software included on the CD-ROM (supplied) in order to open a RAW image recorded on this camera. With this software, a RAW





image can be opened and converted to a common format, such as JPEG or TIFF, and its white balance, color saturation, contrast, etc., can be readjusted.

- The RAW format image cannot be printed using a DPOF (print) designated printer.
- You cannot set [Auto HDR] or [Picture Effect] on RAW format images.
- RAW images shot with the camera have a resolution of 14 bits per 1 pixel. However, this is limited to 12 bits in the following situations:
 - Long Exposure NR
 - BULB shooting
 - Continuous shooting (including multiple shooting, such as continuous shooting in Superior Auto mode)

Detecting faces

The camera detects faces, adjusts the focus, exposure, performs image processing, and adjusts flash settings.

Fn button →  (**Smile/Face Detect.**) → **Select the desired setting**

 (Face Detection Off)	Turns off Face Detection.
 (Face Detection On (Regist. Faces))	Enables Face Detection and prioritizes recognized faces that have been registered in [Face Registration] (page 142).
 (Face Detection On)	Enables Face Detection, but does not prioritize recognized faces.
 (Smile Shutter)	Detects and shoots a smile automatically.

The Face Detection frame

When the camera detects faces, gray Face Detection frames appear. When the camera judges that autofocus is possible, the Face Detection frames turn white. When you press the shutter button halfway down, the Face Detection frames turn green.



Face Detection frames (gray)

Face Detection frames (white)

- If a face is not positioned inside the AF area available when you press the shutter button halfway down, the AF area that is used for focusing turns green.
- When the camera detects multiple faces, the camera automatically selects a priority face and the single Face Detection frame turns white. A magenta frame appears on a face that is registered with [Face Registration].

Shooting technique

- Compose to overlay the Face Detection frame and the AF area.

Notes

- When the exposure mode is Sweep Panorama or Tele-zoom Continuous Priority AE, the Face Detection function cannot be used.
- Up to 8 faces can be detected.
- The camera may not detect any faces, or may detect some other object, depending on the shooting conditions.

Face Registration

The camera detects faces for which information has been registered in advance.

1 MENU button → **⚙ 6** → **[Face Registration]** → **[New Registration]**

2 Align the guide frame with the face to be registered, and press the shutter button.

3 Select [Enter] with ▲ on the multi-selector, then press the center of the multi-selector.

- Up to 8 faces can be registered.
- Shoot the face from the front in a brightly lit place. The face may not be registered correctly if it is obscured by a hat, a mask, sunglasses, etc.

To change the priority of faces previously registered

If you have registered multiple faces, the priority for each face is automatically set in the order of registration. You can change the priority order.

MENU button → **⚙ 6** → **[Face Registration]** → **[Order Exchanging]** → **Select a face for which you want to change the priority and the priority level**

To delete a registered face

You can delete a registered face.

MENU button → **⚙ 6** → **[Face Registration]** → **[Delete]** → **Select the face you want to delete**

- When you select [Delete All], you can delete all registered faces at one time.

Notes

- Even if you select [Delete], the data on registered faces remain stored in the camera. If you also want to delete this data from the camera, select [Delete All].
- The registered face is not deleted even if you use [Initialize].

Auto Port. Framing

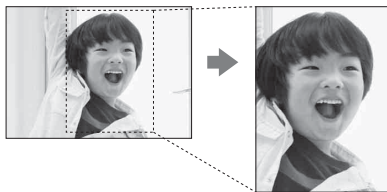

When the camera detects and shoots a face, the captured image is automatically trimmed into a suitable composition. Both the original and the trimmed images are saved.

The trimmed image is recorded with the same image size as that of the original image.

-  turns to green when the trimming feature is available in Live View mode.
- The frame that shows the trimmed area is indicated on the auto review screen after the shot.

Fn button →  (**Auto Port. Framing**) → **Select the desired setting**

The default setting is [Off].

Notes



- The Auto Port. Framing function cannot be used when the exposure mode is set to Sweep Panorama, or Tele-zoom Continuous Priority AE, Movie, or [Hand-held Twilight], [Sports Action] in Scene Selection.
- The trimmed image may not be the best possible composition, depending on the shooting conditions.
- When [Quality] is set to [RAW] or [RAW & JPEG], this function cannot be used.

- This feature cannot be used with the following functions: continuous shooting, continuous bracket, [Multi Frame Noise Reduct.], [Auto HDR], the zoom feature of the camera, manual focus, or [Soft Focus], [HDR Painting], [Rich-tone Mono.], [Miniature] in Picture Effect.

Smile Shutter

When the camera detects a smile, the shutter is released automatically.

1 Fn button → (Smile/Face Detect.) → [Smile Shutter On: Normal Smile] → Select the desired Smile Detection Sensitivity mode with ◀/▶ on the multi-selector

You can set the sensitivity of the Smile Shutter function for detecting smiles to one of the following 3 options:  (On: Slight Smile),  (On: Normal Smile), and  (On: Big Smile).

- When the Smile Shutter is activated, the Smile Detection Sensitivity indicator appears on the screen.

2 Wait for a smile to be detected.

The camera detects a smile and the focus is confirmed. When the smile level exceeds the ◀ point on the indicator, the camera records images automatically.

- When the camera detects the target faces, orange Face Detection frames appear around the faces. The Face Detection frames turn green when these subjects come into focus.
- When [Auto Port. Framing] is set to [Auto], the image will be automatically trimmed to provide a suitable composition.

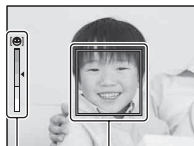

Face Detection frame (orange)

Smile Detection Sensitivity indicator

3 To stop shooting, Fn button → (Smile/Face Detect.) → Select an item other than [Smile Shutter].

Shooting techniques

- To focus on the smile, overlay the Face Detection frame and AF area.
- Do not cover the eyes with bangs, etc. The subject should be smiling.
- Do not obscure the face with a hat, a mask, sunglasses, etc.

- Try to orient the face in front of the camera and keep it as level as possible.
- Hold a clear smile with an open mouth. The smile is easier to detect when the teeth are showing.
- If you press the shutter button while the Smile Shutter function is activated, the camera shoots the image, and then returns to Smile Shutter.

Notes

- The Smile Shutter function cannot be used when the exposure mode is set to Sweep Panorama, Tele-zoom Continuous Priority AE, Movie, or [Hand-held Twilight] in Scene Selection, or the manual focus is selected.
- The drive mode is automatically set to [Single Shooting] or [Remote Cdr.].
- The AF illuminator does not work with the Smile Shutter function.
- If the camera does not detect a smile, change the settings for Smile Detection Sensitivity.
- Smiles may not be detected correctly, depending on the shooting conditions.
- If the camera tracks a face using the Object Tracking function with Smile Shutter turned on, the face becomes the target of the smile detection feature (page 95).

Zooming

You can magnify images with a higher scale than the optical zoom.

Zooming in in one step (Smart teleconverter)

You can zoom in to the center of an image using the smart teleconverter and record the image.

Press the button.

- Each time you press the  button, the zoom scaling changes as follows:
Approx. $\times 1.4$ \rightarrow Approx. $\times 2$ \rightarrow Off

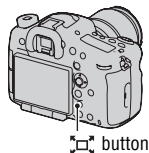

The image size is as follows, based on the zoom scaling.

Zoom scaling	Image size
Approx. $\times 1.4$	M or S
Approx. $\times 2$	S

Notes

- The smart teleconverter is unavailable
 - When the exposure mode is set to Sweep Panorama.
 - [Quality] is set to [RAW] or [RAW & JPEG].
- If [Focus Magnifier] or [Zoom] has been assigned, change the setting back to [Smart Telecon.] (pages 103, 147).
- When the smart teleconverter is available, [Metering Mode] is set to [Multi segment].
- You cannot use the smart teleconverter function with movies.

Zooming in holding the current resolution of the image (Clear Image Zoom)

The Clear Image Zoom feature allows the camera to zoom in holding the current resolution of the image.

You can scale up the zoom by using the Smart Zoom or Digital Zoom feature.

1 MENU button → ⚙ **4** → [Smart Telecon. Button] → [Zoom]

2 Press the  button.

3 Magnify the image up to the desired zoom factor with ◀/▶ on the multi-selector.



- You can magnify the image at wider intervals with ▲/▼.



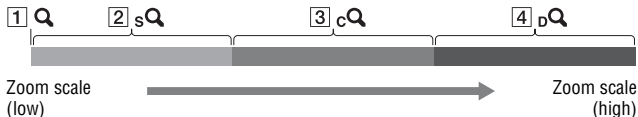

The zoom features available with this camera

The icon displayed on the screen changes as follows according to the zoom scale.



- 1 Q**: The zoom feature of the camera is not used (×1.0 is indicated).
- 2 sQ** Smart Zoom: You can magnify images by trimming them slightly. (Available only when [Image Size] is set to M or S.)
- 3 cQ** Clear Image Zoom: You can magnify images using a high-quality image process.
- 4 dQ** Digital Zoom: You can magnify images using an image process.

Setting	Image size	Zoom scale with optical zoom (Upper row: Full-frame size shooting/lower row: APS-C size shooting)	
		Zoom scale	Icon
Zooms images by trimming them in the available range (without deterioration of image quality). Clear Image Zoom: Off Digital Zoom: Off	L	–	
	M	About 1.5× About 1.5×	sQ 
	S	About 2.3× About 2.3×	sQ 

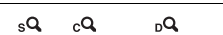
Setting	Image size	Zoom scale with optical zoom (Upper row: Full-frame size shooting/lower row: APS-C size shooting)	
Gives priority to image quality when zooming images. Clear Image Zoom: On Digital Zoom: Off	L	About 2× About 2×	
	M	About 3× About 3×	
	S	About 4.5× About 4.6×	
Gives priority to higher magnification when zooming images. Clear Image Zoom: On Digital Zoom: On	L	About 4× About 4×	
	M	About 6.1× About 6×	
	S	About 9.1× About 9.1×	

Notes

- The zoom feature of the camera is unavailable
 - When the exposure mode is set to Sweep Panorama.
 - [Quality] is set to [RAW] or [RAW & JPEG].
- The [Clear Image Zoom] is unavailable
 - When the exposure mode is set to Tele-zoom Continuous Priority AE.
 - The drive mode is set to Continuous Shooting or continuous bracket shooting.
- You cannot use the Smart Zoom or [Clear Image Zoom] function with movies.
- When the electronic zoom is available, [Metering Mode] is set to [Multi segment].

To change the setting of [Clear Image Zoom]

The default setting is [On].

MENU button →  2 → [Clear Image Zoom] → Select the desired setting

To change the setting of [Digital Zoom]

The default setting is [Off]. If you want to use higher magnification regardless of the deterioration of the image, set it to [On].

MENU button →  2 → [Digital Zoom] → Select the desired setting

Reducing the noise in an image

Long Exposure NR

When you set the shutter speed to 1 second or longer (Long exposure shooting), noise reduction is turned on for the same duration that the shutter is open. This is to reduce the grainy noise typical in a long exposure. When noise reduction is in progress, a message appears and you cannot take another picture. Select [On] to prioritize the image quality. Select [Off] to prioritize the timing of shooting.

MENU button →  **2** → **[Long Exposure NR]** → **Select the desired setting**

Notes

- When the exposure mode is set to Sweep Panorama or Tele-zoom Continuous Priority AE, or continuous shooting, continuous bracketing, [Sports Action] or [Hand-held Twilight] in Scene Selection, or ISO is set to [Multi Frame Noise Reduct.], noise reduction is not performed even when it is set to [On].
- When the exposure mode is set to Auto Mode or Scene Selection, you cannot turn off noise reduction.
- Even when the shutter speed is set to 1 second or longer, noise reduction may not work, depending on the shooting conditions.

High ISO NR

The camera effectively reduces the noise that becomes more noticeable especially when the ISO sensitivity is higher.

Normally, set it to [Normal]. You can also select [Low] or [Off].

MENU button →  **2** → **[High ISO NR]** → **Select the desired setting**

Notes

- When the exposure mode is set to Auto Mode, Sweep Panorama, or Scene Selection, this item cannot be set.
- Noise reduction is not performed on RAW images.

Setting the color space

The way colors are represented with combinations of numbers or the range of color reproduction is called “color space.” You can change the color space, depending on your purpose.

MENU button →  **3** → **[Color Space]** → **Select the desired setting**

sRGB	This is the standard color space of the digital camera. Use sRGB in normal shooting, such as when you intend to print out the images without any modification.
AdobeRGB	This has a wide range of color reproduction. When a large part of the subject is vivid green or red, Adobe RGB is effective. <ul style="list-style-type: none">• The file name of the image starts with “_DSC.”

Notes

- Adobe RGB is for applications or printers that support color management and DCF2.0 option color space. Using some applications or printers that do not support them may result in or print images that do not faithfully reproduce the color.
- When displaying images that were recorded with Adobe RGB on non-Adobe RGB-compliant devices, the images are displayed with low saturation.

Movie recording setup

This section describes movie recording with advanced operations.

Shooting techniques

- Start recording after you adjust the focus.
- The following settings that were set during still image shooting can be used:
ISO/White Balance/Creative Style/Exposure compensation/AF area/Metering Mode/Face Detection/Object Tracking/D-Range optimizer/Lens Comp.: Shading/Lens Comp.: Chro. Aber./Lens Comp.: Distortion/Picture Effect
- ISO, exposure compensation, Object Tracking, or AF area can be adjusted during movie recording.
- If you assign [AF lock] to the AEL button, ISO button, AF/MF button, custom button, or preview button, you can lock the focus by pressing these buttons in autofocus mode.
- You can zoom in or out during movie recording using the digital zoom (page 147).
- You can output the image without the recording information displayed during movie recording when [HDMI Info. Display] is set to [Off] (page 173).

Notes

- In movie recording, the shooting range (the angle of view) is narrower than that of still image shooting when the SteadyShot function is set to [On]. To shoot using the same angle of view as a 16:9 still image, set the SteadyShot function to [Off] (page 60).
- When the [For viewfinder] screen is displayed on the LCD screen, the LCD screen is switched to the [Display All Info.] screen at the moment movie recording starts.
- Do not shoot a strong light source, such as the sun. The internal mechanism of the camera may be damaged.
- When you import AVCHD movies to a computer, use “PlayMemories Home” (page 199).
- When you continue to shoot for a long time, the temperature of the camera rises and the image quality may deteriorate.
- Since the shutter speed and aperture are automatically adjusted, the shutter speed will be higher and the movement of the subject may not be smooth under bright

conditions. Selecting manual focus and adjusting the shutter speed or aperture may make the movement smoother (page 101).

- A value for the ISO sensitivity between ISO 100 and ISO 6400 can be selected when you record movies. If you start movie recording with a value of ISO 6400 or larger selected, the ISO sensitivity is switched to ISO 6400. If you start movie recording with a value of ISO 100 or smaller selected, the ISO sensitivity is switched to ISO 100. When you finish recording your movie, the ISO sensitivity setting is returned to the previous value.
- When ISO is set to [Multi Frame Noise Reduct.], [AUTO] is temporarily selected.
- You cannot select [Soft Focus], [HDR Painting], [Rich-tone Mono.], or [Miniature] in Picture Effect. When movie recording starts, Picture Effect is temporarily set to [Off].

Changing the tracking sensitivity of autofocus during movie recording

When you record fast moving subjects, select [High], and when several subjects are moving or crossing back and forth, select [Low].

MENU button →  **1** → [AF Tracking Duration] → **Select the desired setting**

Recording movies with the shutter speed and aperture adjusted

You can record movies with the shutter speed and aperture adjusted, controlling the background defocus or fluidity as intended.

1 **Fn button** →  **(Focus Mode)** →  **(Manual Focus)**
(page 101).





2 **Set the mode dial to**  **(Movie)** (page 68).

- To change the mode, press the Fn button, then select another mode.

3 **Adjust the shutter speed and aperture value with the front or rear control dial.**

- When [Shutter speed] or [Aperture] is assigned to the silent multi-controller, adjustment is also available with the silent multi-controller (page 32).

4 Adjust the focus, then press the MOVIE button to start recording.

 P (Program Auto) (77)	Allows you to shoot with the exposure adjusted automatically (both the shutter speed and the aperture value). The other settings can be adjusted manually, and your setting values can be saved.
 A (Aperture Priority) (78)	Allows you to shoot after adjusting the aperture value manually using the front or rear control dial.
 S (Shutter Priority) (80)	Allows you to shoot after adjusting the shutter speed manually using the front or rear control dial.
 M (Manual Exposure) (82)	Allows you to shoot after adjusting the exposure manually (both the shutter speed and the aperture value) using the front or rear control dial.

Auto Slow Shutter

Setting [Auto Slow Shutter] to [On] reduces the noise on even dark portions.

If you set [Auto Slow Shutter] to [Off], the image is darker than when it is set to [On], but you can shoot movies with less camera shake and smoother frames.

MENU button →  **1** → **[Auto Slow Shutter]** → **Select the desired mode**

Note

- This function is available only when both the exposure mode is set to other than M/S and the ISO sensitivity is set to [AUTO].

File Format

MENU button →  **1** → **[File Format]** → **Select the desired format**

AVCHD	<p>Records 60i/50i movies, 24p/25p movies or 60p/50p movies in AVCHD format. This file format is suitable for viewing the movie on a high-definition TV.</p> <p>You can create a Blu-ray disc, an AVCHD recording disc, or a DVD-Video disc using the supplied software “PlayMemories Home.”</p> <ul style="list-style-type: none"> • 60i/50i movies are recorded at either 60 fields/second or at 50 fields/second, respectively. Both 60i and 50i movies utilize the interlace scanning system, Dolby Digital audio, and the AVCHD format. • 24p/25p movies are recorded at either 24 frames/second or at 25 frames/second, respectively. Both 24p and 25p movies utilize the progressive scanning system, Dolby Digital audio, and the AVCHD format. • 60p/50p movies are recorded at either 60 frames/second, or at 50 frames/second, respectively. Both 60p and 50p movies utilize the progressive scanning system and Dolby Digital audio, and the AVCHD format.
MP4	<p>Records mp4 (AVC) movies. This format is suitable for WEB uploads, e-mail attachments, etc.</p> <ul style="list-style-type: none"> • Movies are recorded in MPEG-4 format at about 30 frames/second, utilizing the progressive scanning system, AAC audio, and the mp4 format. • You cannot create a disc from the movies recorded in this format using the supplied software “PlayMemories Home.”

Record Setting

The higher the average bit-rate, the higher the image quality.

MENU button →  **1** → **[Record Setting]** → **Select the desired size**

[File Format]: [AVCHD]

Record Setting	Bit-rate	Recording
60i 24M(FX)* 50i 24M(FX)**	Maximum 24 Mbps	Records high image quality movies of 1920 × 1080 (60i/50i).
60i 17M(FH)* 50i 17M(FH)**	Approx. average 17 Mbps	Records standard image quality movies of 1920 × 1080 (60i/50i).
60p 28M(PS)* 50p 28M(PS)**	Maximum 28 Mbps	Records highest image quality movies of 1920 × 1080 (60p/50p).
24p 24M(FX)* 25p 24M(FX)**	Maximum 24 Mbps	Records high image quality moves of 1920 × 1080 (24p/25p). This produces a cinema-like atmosphere.
24p 17M(FH)* 25p 17M(FH)**	Approx. average 17 Mbps	Records standard image quality movies of 1920 × 1080 (24p/25p). This produces a cinema-like atmosphere.

[File Format]: [MP4]

Record Setting	Average bit-rate	Recording
1440×1080 12M	Approx. 12 Mbps	Records movies of 1440 × 1080.
VGA 3M	Approx. 3 Mbps	Records movies of VGA size.

* 1080 60i-compatible device

** 1080 50i-compatible device

Notes

- Movies recorded with the [60p 28M(PS)]/[50p 28M(PS)], [60i 24M(FX)]/[50i 24M(FX)] or [24p 24M(FX)]/[25p 24M(FX)] setting in [Record Setting] are converted by “PlayMemories Home” in order to create an AVCHD recording disc. This conversion can take a long time. Also, you cannot create a disc with the original image quality. If you want to keep the original image quality, you must store your movies on a Blu-ray disc.
- To watch 60p/50p or 24p/25p movies on a TV, you need a TV that is compatible with 60p/50p or 24p/25p. If you use a non-compatible TV, the movies are converted to 60i/50i and output to the TV.

Audio Rec Level

You can adjust the audio recording level by monitoring the level meter.

MENU button →  **2** → **[Audio Rec Level]** → **Select the desired level with </> on the multi-selector**

+ side: The audio recording level is increased.

– side: The audio recording level is decreased.

Reset: To set the recording level to the default.

Shooting techniques

- We recommend that you use headphones to check the level when adjusting the setting.
- Set a lower level to naturally capture continuous loud sound. To capture quieter sound at an easy-to-hear level, increase this setting.

Notes

- The limiter is always working regardless of the Audio Rec Level setting.
- This function is available only when the exposure mode is set to Movie.
- Audio recording level adjustment is available for the internal microphone and the  (Microphone) jack.

Audio Level Display

You can select whether or not to display the audio level on the screen.

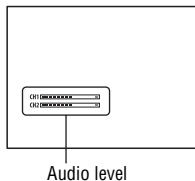

MENU button →  **2** → **[Audio Level Display]** → **Select the desired setting**

Notes

- The audio level is not displayed in the following cases:
 - [Audio Recording] is set to [Off].
 - The screen mode is set to [No Disp. Info].
- Set the exposure mode to Movie. Before recording, the audio level can be displayed only when it is set to Movie.

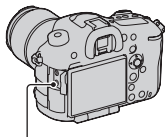
Checking the audio using headphones**1 Connect headphones to the  (headphones) jack.** (Headphones) jack**2 Set the mode dial to  (Movie).**

You can monitor the sound when recording or playing back movies.

Audio Output Timing

When using headphones, you can change the echo compensation settings during movie recording.

MENU button →  **2** → **[Audio Output Timing]** → **Select the desired setting**

Live	Outputs audio without delay in movie recording. Select this setting when you are concerned about the delay of the monitor sound you are recording.
Lip Sync	Outputs audio synchronized with the video in movie recording. Prevents the sound from being out of synchronization with the video.

Audio Recording

When you record movies, the operating noise of the camera or lens may be recorded. You can record movies without audio.

MENU button →  **2** → **[Audio Recording]** → **[Off]**

To reduce wind noise

You can reduce wind noise by cutting bass sound input from the built-in microphone.

MENU button →  **2** → **[Wind Noise Reduct.]** → **[On]**

Notes

- Setting this item to [On] may cause some bass sound to be recorded with too low a volume. Set it to [Off] when the wind is not blowing.
- When an external microphone (sold separately) is used, this item does not function.

To record movies without the operating sounds of the dials

Using the silent multi-controller, you can change settings without using the front or rear control dial (page 32).

MENU button →  **1** →  **[Silent Controller]** → **Select the desired setting**

When the focus mode is set to manual focus, you can disable recording of the operating noise of the lens for the autofocus (page 101).

Using the playback functions

Selecting the memory card used to be played back

MENU button →  **2** → **[Select Playback Media]** → **Select the desired slot**

Note

- When there is no memory card inserted in the selected slot, no images are played back. Select the slot where the memory card is being inserted.

Switching between still images and movies (View Mode)

Selects whether still images or movies are to be played back.

MENU button →  **1** → **[Still/Movie Select]** → **Select the desired setting**

Folder View(Still)	Displays still images by folder.
Folder View(MP4)	Displays movies (MP4) by folder.
AVCHD View	Displays only AVCHD movies.

Enlarging images

A still image can be enlarged for closer examination. This is convenient to check the focus condition of a recorded image.

1 Display the image you want to enlarge, then press the  button.

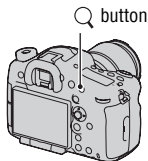

2 Zoom the image in or out with the rear control dial.

- Rotating the front control dial switches the image at the same display magnification. When you shoot multiple images with the same composition, you can compare their focus conditions.

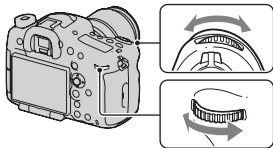

3 Select the portion you want to enlarge with ▲/▼/◀/▶ on the multi-selector.

To cancel the enlarged playback

Press the center of the multi-selector so that the image returns to the normal size.

Note

- The images recorded with [Image Size] set to [S:2.0M] in APS-C size shooting cannot be magnified.

Switching to the display of the image list

You can display multiple images on the screen simultaneously during playback.

1 Press the button.

The image index screen is displayed.

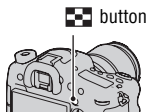

2 Press the DISP button repeatedly to select the number of images displayed on one page of the image index screen.

- The screen changes between 4 images and 9 images

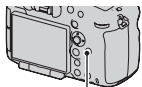

DISP button

To return to the single-image screen

Press the center of the multi-selector when you select the desired image.

To display the desired folder

Select the left bar on the image index screen with the multi-selector, then select the desired folder with ▲/▼. Pressing the center of the multi-selector when the left bar is selected switches between still images and movies (page 160).



Rotating an image

1 Display the image you want to rotate, then press the button.

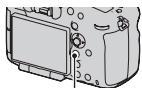

crop button

2 Press the center of the multi-selector.

The image is rotated counter-clockwise. When you want to do another rotation, repeat step 2.

- Once you rotate the image, the image is played back in the rotated position, even after you turn off the power.

To return to the normal playback screen

Press the  button again.



Notes

- You cannot rotate movies.
- When you copy rotated images to a computer, “PlayMemories Home” contained on the CD-ROM (supplied) can display the rotated images correctly. However, the images may not be rotated depending on the software.

Slide Show

MENU button → 1 → [Slide Show] → [Enter]

Plays back recorded images in order (Slide Show). The slide show automatically stops after all the images have been played back.

- You can view the previous/next image with / on the multi-selector.
- You cannot pause the slide show.

To end in the middle of the slide show

Press the center of the multi-selector.

To choose the interval between the images in slide show

MENU button →  1 → [Slide Show] → [Interval] → Select the desired number of seconds

To play back repeatedly

MENU button →  1 → [Slide Show] → [Repeat] → [On]

To play back 3D-images

If you connect the camera to a 3D-compatible TV using an HDMI cable (sold separately), you can play back 3D-images. Also refer to the operating instructions supplied with the TV.

MENU button →  1 → [Slide Show] → [Image Type] → [Display 3D Only]

Note

- This camera cannot record 3D-images.

Playback Display

You can set the playback orientation of images recorded in portrait orientation.

MENU button →  **2** → **[Playback Display]** → **Select the desired setting**

The screen displayed for playback mode

Switching the screen during playback

Each time you press the DISP button, the screen changes as follows.

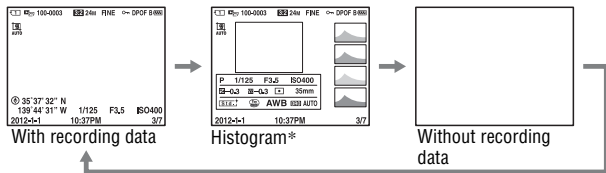

* When the image has a high-key or low-key portion, that portion is flashed on the histogram display (Luminance limit warning).

List of icons on the histogram display

For detailed information with "With recording data" selected in the screen mode, see page 25.

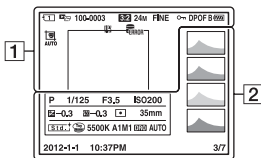

1

Display	Indication
	Memory card (51, 234)
	View mode (160)
100-0003	Folder - file number (206)
3:2 16:9	Aspect ratio of still images (139)

Display	Indication
24M 10M 4.6M 20M 8.7M 3.9M 10M 4.6M 2.0M 8.7M 3.9M 1.7M	Image size of still images (137)
WIDE STD	

Display	Indication
RAW RAW+J X.FINE FINE STD	Image quality of still images (139)
	Protect (167)
DPOF	DPOF set (168)
	Remaining battery warning (53)
B 1 2 100%	Remaining battery (53)
FULL ERROR	Database file full (222)/ Database file error (222)
	Overheating warning (12)

2

Display	Indication
	Histogram (89)
	Exposure mode (68)
1/125	Shutter speed (80)
F3.5	Aperture (78)
ISO200	ISO sensitivity (124)
-0.3	Exposure compensation (106)
-0.3	Flash compensation (120)
	Metering mode (109)
35mm	Focal length
	Creative Style (130)

Display	Indication
	Picture Effect (129)
AWB 5500K A1 M1	White balance (Auto, Preset, Color temperature, Color filter, Custom) (133)
D-R OFF DRO HDR HDR 1	D-Range Optimizer (126)/Auto HDR/Auto HDR image warning (127)
2012-1-1 10:37PM	Date of recording
3/7	File number/Number of images in the view mode

Protecting images (Protect)

You can protect images against accidental erasure.

1 MENU button →  1 → [Protect] → [Multiple Img.]

2 Select the image you want to protect with ◀/▶ on the multi-selector, then press the center of the multi-selector.



A ✓ mark is put in the check box.

- To cancel a selection, press the center again.
-

3 To protect other images, repeat step 2.

- You can select all the images in the folder by selecting the bar on the left of the image index screen.
-

4 Press the MENU button.

5 Select [OK] with ▲, then press the center of the multi-selector.

To cancel the protection of all the images or movies

You can cancel the protection of all the images or movies in the folder currently displayed.

MENU button →  1 → [Protect] → [Cancel All Images], [Cancel All Movies(MP4)] or [Cancel All AVCHD view files]

Specifying printing

Specifying DPOF

Using the camera, you can specify the still images before you print images at a shop or with your printer. Follow the procedure below.

DPOF specifications are left with images after printing. It is recommended that you unspecify them after printing.

1 MENU button →  1 → [Specify Printing] → [DPOF Setup] → [Multiple Img.]

2 Select the image with ◀/▶ on the multi-selector, then press the center of the multi-selector.

3 Place a ✓ mark by pressing the center of the multi-selector.

- To unspecify DPOF, select the image again, then press the center of the multi-selector.

4 Press the MENU button.

5 Select [OK] with ▲, then press the center of the multi-selector.

Notes

- You cannot specify DPOF on RAW data files.
- You cannot specify the number of images to be printed.

Date Imprint

You can date images when printing them. The position of the date (inside or outside the image, character size, etc.) depends on your printer.

MENU button →  1 → [Specify Printing] → [Date Imprint] → [On]

Note

- This function may not be available, depending on the printer.

Copying images

You can copy images from a memory card inserted in the slot selected with [Select Playback Media] to a memory card inserted in the other slot. The copy process can be done per type of the image (still images/movies) (page 160).

MENU button →  **2** → **[Copy]**

Note

- It may take some time to copy a lot of images. Use a sufficiently charged battery pack.

Deleting images (Delete)

You can delete only unnecessary images, or all the images. Once you have deleted an image, you cannot restore it. Check whether to delete the image or not beforehand.

Note

- Protected images cannot be deleted.

Delete (Multiple Img.)

1 MENU button →  1 → [Delete] → [Multiple Img.]

2 Select the images you want to delete with the multi-selector, then press the center of the multi-selector.

A ✓ mark is put in the check box.

- To cancel a selection, press the center again.



Total number

3 To delete other images, repeat step 2.

- You can select all the images in the folder by selecting the bar on the left of the image index screen.

4 Press the MENU button.

5 Select [OK] with ▲, then press the center of the multi-selector.

Deleting all images or movies visible in the current view mode

You can delete all still images or movies visible in the current display view mode.

1 MENU button →  1 → [Delete] → [All in Folder] or [All AVCHD view files]

2 Select [Delete] with ▲ on the multi-selector, then press the center of the multi-selector.

To display the desired folder

Select the bar on the left of the image index screen with the multi-selector, then select the desired folder with ▲/▼.

Viewing images on a TV screen

To view images recorded on the camera on a TV set, an HDMI cable (sold separately) and an HD TV equipped with an HDMI connector are required.

1 Turn off both your camera and the TV, and connect the camera to the TV.

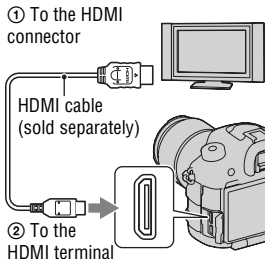



2 Turn on the TV and switch the input.

- See also the operating instructions supplied with the TV.

3 Turn on the camera, and press the button.

Images shot with the camera appear on the TV screen.

Select the desired image with   on the multi-selector.

- The LCD screen on the camera does not turn on.

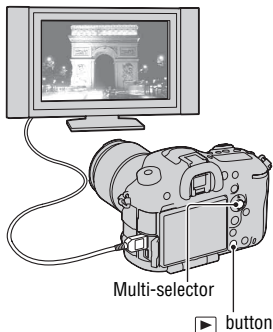

Notes

- Use an HDMI cable with the HDMI logo.
- Use an HDMI mini connector on one end (for the camera), and a connector suitable for connection to your TV on the other end.

- When images cannot be displayed properly, set [HDMI Resolution] in the  Setup menu to [1080p] or [1080i], according to your TV.
- Some devices may not work properly.
- Do not connect the output connector of the device with the HDMI terminal on the camera. This may cause a malfunction.

On “PhotoTV HD”

This camera is compatible with the “PhotoTV HD” standard.

By connecting Sony’s PhotoTV HD-compatible devices using an HDMI cable, a whole new world of photos can be enjoyed in breathtaking Full HD quality.

“PhotoTV HD” allows for a highly-detailed, photo-like expression of subtle textures and colors.

HDMI Info. Display

When a TV using an HDMI cable (sold separately) is connected, you can display images on the TV screen without recording information, and simultaneously display images on the LCD screen of the camera with recording information.

1 MENU button →  **2** → [HDMI Info. Display] → [Off]

2 Connect the camera to a TV (page 172).

Live view images are displayed on the TV screen without recording information.

Live view images are displayed on the LCD screen of the camera with recording information.

Using “BRAVIA” Sync

By connecting the camera to a TV that supports “BRAVIA” Sync using an HDMI cable, you can operate the camera with the TV Remote Control.

1 Connect a TV that supports “BRAVIA” Sync to the camera (page 172).

The input is automatically switched and the image shot with the camera appears on the TV screen.

2 Press the SYNC MENU button on the TV Remote Control.

3 Operate with the buttons on the TV Remote Control.

The items for SYNC MENU

Slide Show	Plays back images automatically.
Single-image playback	Returns to the single-image screen.
Image Index	Switches to the image index screen.
Still/Movie Select	Selects still images or movies to be played back.
Delete	Deletes images.

Notes

- The operations available are restricted when the camera is connected to a TV using an HDMI cable.
- Only TVs that support “BRAVIA” Sync can provide these operations. The SYNC MENU operations differ depending on the TV connected. For details, refer to the operating instructions supplied with the TV.
- If the camera performs unnecessary operations in response to the TV Remote Control when the camera is connected to another manufacturer’s TV using an HDMI connection, set [CTRL FOR HDMI] in the  Setup menu to [Off].

Setting the other functions of the camera

Release w/o Lens

You can release the shutter when no lens is attached. Select this when you attach the camera on an astronomical telescope, etc.

MENU button → **⚙ 1** → **[Release w/o Lens]** → **[Enable]**

Note

- Correct metering cannot be achieved when you use lenses that do not provide a lens contact, such as the lens of an astronomical telescope. In such cases, adjust the exposure manually by checking it on the recorded image.

Grid Line

The grid line is an auxiliary line for shooting composition. You can set the grid line to on/off or select the type of grid line. The available range of movie recording is also displayed.

MENU button → **⚙ 2** → **[Grid Line]** → **Select the desired setting**

Auto Review

You can check the recorded image on the screen right after the shooting. You can change the displayed time.

MENU button → **⚙ 2** → **[Auto Review]** → **Select the desired setting**

Notes

- In auto review, the image will not be displayed in the vertical position even if [Playback Display] is set to [Auto Rotate] (page 164).
- In auto review, the camera may display an image to which an image process, such as [Lens Comp.: Distortion], has not been performed, then display the same image to which an image process has been performed.

Func. of AEL button

The function of the AEL button can be selected from the following 2 functions (page 109):

- Holding the locked exposure value by pressing the AEL button while the button is held down ([AEL hold]).
- Holding the locked exposure value by pressing the AEL button until the button is pressed again ([AEL toggle]).

When [☐ AEL hold] or [☐ AEL toggle] is selected, the exposure is locked in spot metering mode.

MENU button →  **4** → **[Func. of AEL button]** → **Select the desired setting**

Notes

- While the exposure value is locked, ✱ appears on the LCD screen and in the viewfinder. Be careful not to reset the setting.
- The “hold” and “toggle” settings affect the manual shift (page 83) in the manual mode.
- The metering value set with [AEL toggle] is released after the camera returns from the power save mode or is used to play back images.

To assign another function to the AEL button

You can assign one of the following functions to the AEL button in addition to the AEL function:

Exposure Comp./Drive Mode/Flash Mode/Focus Mode/AF area/Smile/
Face Detect./Auto Port. Framing/ISO/Metering Mode/Flash Comp./White
Balance/DRO/Auto HDR/Creative Style/Picture Effect/Image Size/
Quality/Memory/FEL Lock hold/FEL Lock toggle/Object Tracking/AF/
MF Control Hold/AF/MF Control Toggle/AF lock/AF On/Aperture
Preview/Shot. Result Preview/Focus Magnifier

ISO Button, AF/MF button, Preview Button

You can also assign another function to the ISO button, AF/MF button or preview button. The functions available are the same as those of [Func. of AEL button] (page 176).

MENU button →  4 → [ISO Button], [AF/MF button] or [Preview Button] → **Select the desired setting**

Custom button

The FEL lock function is assigned to the custom button in the default settings (page 122). You can also assign another function to the custom button. The functions available are the same as those of [Func. of AEL button].

MENU button →  4 → [Custom button] → **Select the desired setting**

Electronic Front Curtain Shutter

The electronic front curtain shutter function shortens the time lag between shutter releases.

MENU button →  6 → [Front Curtain Shutter] → **Select the desired setting**

Notes

- When you shoot at high shutter speeds with a large diameter lens attached, the ghosting of a blurred area may occur, depending on the subject or shooting conditions. In such cases, set this item to [Off].
- When a Minolta/Konica Minolta lens is used, set this item to [Off].
- When you select a faster shutter speed, the brightness of the screen may be unequal, depending on the situation. In such cases, set this item to [Off].

LCD Brightness

The brightness of the LCD screen is automatically adjusted to the surrounding lighting conditions using the light sensor (page 17). You can set the brightness of the LCD screen manually, or select a suitable setting for a sunny day outdoors.

MENU button →  1 → [LCD Brightness] → **Select the desired setting**

Notes

- When it is set to [Auto], do not cover the light sensor with your hand or other object.
- When using the camera with the AC-PW10AM AC Adaptor (sold separately), the brightness of the LCD screen is always set to the brightest setting even if you select [Auto].
- Since the [Sunny Weather] setting is too bright to use indoors, set it to [Auto] or [Manual] indoors.

Viewfinder Bright.

The brightness of the viewfinder is automatically adjusted to the lighting conditions of the subject.

You can set the brightness of the viewfinder manually.

MENU button →  **1** → **[Viewfinder Bright.]** → **[Manual]** → **Select the desired setting**

Power Save

You can shorten the waiting time until the camera turns to the power save mode when it is not being operated to prevent the battery from being consumed. If you operate the camera, for example, pressing the shutter button halfway down, the camera returns to the shooting mode. If you do not operate the camera for a given period of time, the brightness of the LCD screen is reduced.

MENU button →  **2** → **[Power Save]** → **Select the desired setting**

Note

- When the AC-PW10AM AC Adaptor (sold separately) is used, this item cannot be set to [Max].

To change the waiting time until the camera turns to the power save mode

You can set different time intervals for the camera to switch to power save mode.

MENU button →  **2** → [Power Saving Start Time] → Select the desired time

Notes

- The camera does not turn to power save mode when the camera is connected to a TV or the drive mode is set to [Remote Cdr.].
- If you set this item to [Max], [Power Saving Start Time] is set to [10 Sec].

FINDER/LCD Setting

You can disable the automatic switching of the LCD screen and the viewfinder and enable only the FINDER/LCD button to switch them.

MENU button →  **1** → [FINDER/LCD Setting] → [Manual]

APS-C Size Capture

This camera complies with the 35 mm full-frame standard, however, you can also shoot with the APS-C size. When this item is set to [On], the camera records with the APS-C size even if there is a lens attached to the camera. When a DT lens is attached, APS-C size is selected automatically.

MENU button →  **3** → [APS-C Size Capture] → Select the desired setting

Note

- When [APS-C Size Capture] is set to [On], the image size is automatically changed (page 137).

PAL/NTSC Selector (only for the 1080 50i-compatible device)

When [PAL/NTSC Selector] is set to the NTSC-system before shooting, movies recorded with the camera can be played back on an NTSC-system TV.

MENU button →  **3** → [PAL/NTSC Selector] → **Select the desired setting**

Notes

- This function is provided with 1080 50i-compatible devices only. It is not provided with 1080 60i-compatible devices. The 1080 50i-compatible devices have a “50i” mark on the bottom of the camera.
- If you insert a memory card that has previously been formatted with the PAL system, a message telling you that you must re-format the card appears. When you record using the NTSC system, re-format the memory card or use another memory card.
- When the NTSC mode is selected, the “Running on NTSC.” message always appears on the start-up screen each time you turn the camera on.

Lens compensation

You can automatically compensate the following characteristics: light fall-off at the edges, chromatic aberration, and distortion (only for automatic compensation compliant lenses). For further information on automatic compensation compliant lenses, visit the Sony web site in your area, or consult your Sony dealer or local authorized Sony service facility.

Lens Comp.: Peripheral Shading

Compensates for the shaded corners of the screen caused by certain lens characteristics. This item is set to [Auto] in the default settings.

MENU button → **⚙ 6** → **[Lens Comp.: Shading]** → **Select the desired setting**

Lens Comp.: Chromatic Aberration

Reduces the color deviation at the corners of the screen caused by certain lens characteristics. This item is set to [Auto] in the default settings.

MENU button → **⚙ 6** → **[Lens Comp.: Chro. Aber.]** → **Select the desired setting**

Lens Comp.: Distortion

Compensates for the distortion of the screen caused by certain lens characteristics. This item is set to [Off] in the default settings.

MENU button → **⚙ 6** → **[Lens Comp.: Distortion]** → **Select the desired setting**

Setting the method for recording on a memory card

Recording Mode

You can record the same images on 2 memory cards at the same time, or sort images onto different memory card, based on the type of image. [Standard] is selected in the default settings.

MENU button →  **1** → **[Recording Mode]** → **Select the desired setting**

Standard	Records images only on the memory card inserted in the slot selected with [Select Recording Media] (page 52).
Simult. Rec (Still)	Records still images on both of the memory cards inserted in the 2 slots, regardless of the [Select Recording Media] setting, and records movies on the memory card inserted in the slot selected with [Select Recording Media]. Still images using the same file number will be recorded in the folders that have the same folder number on both memory cards.
Simult. Rec (Movie)	Records movies on both of the memory cards inserted in the 2 slots, regardless of the [Select Recording Media] setting, and records still images on the memory card inserted in the slot selected with [Select Recording Media]. MP4 movies using the same file number will be recorded in the folders that have the same folder number on both memory cards.
Sim. Rec (Still/Movie)	Records still images/movies on both of the memory cards.
Sort(JPEG/RAW)	Records JPEG data on the memory card inserted in the slot selected with [Select Recording Media], and records RAW data on the other memory card.
Sort(Still/Movie)	Records still images on the memory card inserted in the slot selected with [Select Recording Media], and records movies on the other memory card.

Notes

- One of the following memory cards is required to record movies simultaneously:
 - SD cards that match the UHS-I (UHS Speed Class I) interface
 - SD cards that match the Class 10 speed or higher
 - “Memory Stick PRO Duo” media

- Simultaneous recording may take a long time to record images.
- When the simultaneous recording feature or [Sort(JPEG/RAW)] is selected, if an image is not recorded, for example, there is no memory card inserted in one of the two slots, the image cannot be recorded on both memory cards.

Format

Note that formatting irrevocably erases all data on a memory card, including protected images.

MENU button →  **1** → **[Format]** → **Select the desired slot** → **[Enter]**

Notes

- During the format, the access lamp lights up. Do not eject the memory card while the lamp is lit.
- Format the memory card using the camera. If you format it on a computer, the memory card may not be usable with the camera, depending on the format type used.
- Formatting may take several minutes depending on the memory card.
- When the remaining battery time is 1 percent or less, you cannot format memory cards.

File Number

MENU button →  **1** → **[File Number]** → **Select the desired setting**

Series	The camera does not reset numbers and assigns numbers to files in sequence until the number reaches “9999.”
Reset	The camera resets numbers when a file is recorded in a new folder and assigns numbers to files from “0001.” When the recording folder contains a file, a number one higher than the largest number is assigned.

Note

- If you execute [Reset Default], the file number is reset.

Folder Name

The recorded still images are stored in automatically-created folders in the DCIM folder of the memory card.

MENU button →  **1** → **[Folder Name]** → **Select the desired setting**

Standard Form	The folder name format is as follows: folder number + MSDCF. Example: 100MSDCF
Date Form	The folder name format is as follows: folder number + Y (the last digit)/MM/DD. Example: 10020405 (Folder name: 100, date: 2012/04/05)

Note

- The MP4 movie folder form is fixed as “folder number + ANV01.”

Select REC Folder

When a standard form folder is selected and there are 2 or more folders, you can select the folder in which recorded images are stored.

MENU button →  **1** → **[Select REC Folder]** → **Select the desired folder**

Notes

- You cannot select the folder when you select the setting [Date Form].
- When simultaneous or sort recording is selected, you may only select a folder that has the same folder name on both memory cards. If there are no folders that have the same folder name, you can create a folder with [New Folder].

New Folder

You can create a folder in a memory card for recording images.

A new folder is created with a folder number one greater than the largest folder number currently used, and the folder becomes the current recording folder. A folder for still images and a folder for MP4 movies are created at the same time.

MENU button →  **1** → **[New Folder]**

Notes

- If you set [Recording Mode] to other than [Standard] and start recording, a new folder is created on both memory cards with a folder number one greater than the largest folder number currently used.

- If you set [Recording Mode] to other than [Standard] and start recording, a new folder may be created automatically.
- When you insert a memory card that has been used with other equipment into the camera and shoot images, a new folder may be created automatically.
- Up to 4,000 images can be stored in a folder. When the folder capacity is exceeded, a new folder is created automatically.

Recover Image DB

When inconsistencies are found in the image database file, caused by processing images on computers, etc., images on the memory card will not be played back in this form. If this happens, the camera repairs the file.

MENU button →  **2** → **[Recover Image DB]** → **Select the desired slot** → **[Enter]**

Note





- Use a sufficiently charged battery. Low battery power during repairing can cause damage to data.

Upload Settings

You can use the upload function with an Eye-Fi card (commercially available). This item appears when an Eye-Fi card is inserted in a memory card slot 1 of the camera.



MENU button →  **3** → **[Upload Settings]** → **[On]**

The status indicators in communication

	Standby. No images are to be sent.
	Upload standby.
	Connecting.
	Uploading.
	Error.

Notes

- The status indicators in communication are displayed only when [Recording Mode] is set to [Standard].

- Before using an Eye-Fi card, set up the wireless LAN access point and forwarding destination. For details, refer to the operating manual supplied with the Eye-Fi card.
- Eye-Fi cards are sold in the U.S.A, Canada, Japan, and some countries in the EU (as of June in 2012).
- For more information, please contact the manufacturer or vendor directly.
- Eye-Fi cards can be used only in the countries/regions where they were purchased. Use Eye-Fi cards in accordance with the law of the countries/regions where you purchased the card.
- Eye-Fi cards include a wireless LAN function. Do not insert any Eye-Fi cards in the camera when it is prohibited to do so, such as on an airplane. If there is an Eye-Fi card inserted in the camera, set [Upload Settings] to [Off].  OFF is displayed on the screen when [Upload Settings] is set to [Off].
- When you use a brand-new Eye-Fi card for the first time, copy the install file of Eye-Fi manager recorded on the card to your computer before formatting the card.
- Use an Eye-Fi card after updating the firmware to the latest version. For details, refer to the manual that comes with the Eye-Fi card.
- The power save function of the camera does not work while it is uploading images.
- If  (error) is displayed, remove the memory card and reinsert it, or turn off then turn on the power again. If  appears again, the Eye-Fi card may be damaged.
- Wi-Fi network communication may be influenced by other communication devices. If the communication status is poor, move closer to the access point of the Wi-Fi network.
- For details on the file types that can be uploaded, refer to the operating instructions supplied with the Eye-Fi card.
- If you upload an image that was recorded with [GPS On/Off] set to [On], the location information of the image may be made available to a third party. To prevent this, set [GPS On/Off] to [Off] (page 187) (SLT-A99V only).
- This product does not support the Eye-Fi “Endless Memory Mode.” Make sure that Eye-Fi cards that you insert into this product have “Endless Memory Mode” turned off.





Recording location information using the GPS feature (SLT-A99V only)

If the camera has acquired location information using the built-in GPS feature, this information is recorded in the images or movies at that location.

Using the supplied software “PlayMemories Home,” you can import images recorded with location information to a computer and enjoy viewing them with a map which shows their shooting location. See “PlayMemories Home Help Guide” for details.

MENU button →  **2** → **[GPS Settings]** → **[GPS On/Off]** → **[On]**

The indicator changes according to the strength of GPS signal reception.

GPS indicators	GPS reception status
No indicator	[GPS On/Off] is set to [Off].
	Your camera cannot record the location information. Use your camera in an open area.
	Calculating the location information. Wait until the location information is recordable.
	The current location information is recordable.
	There is a problem with the GPS feature. Turn the camera off and on.

To receive a GPS signal

- Proper triangulation is not possible indoors or near tall buildings. Use your camera in an open area outside, and turn on your camera again.
- It may take several tens of seconds to several minutes to acquire the location information. You can shorten the positioning time by using GPS assist data.

Notes

- Right after you turn the camera on, it may take several tens of seconds to several minutes to acquire the location information. If you shoot images with the location information not acquired, the information is not recorded. To record the correct information, wait until the camera can receive radio signals from GPS satellites.
- During take off and landing of an airplane, turn off the camera, as you will be instructed to do by the on-board announcement.
- Use GPS in accordance with the regulations of the place or situation.

- For detailed notes on the GPS feature, see page 232.

GPS Assist Data

The time for the GPS acquiring location information can be shortened by taking in GPS assist data. If the camera connects to the computer with the supplied “PlayMemories Home” software installed, the GPS assist data can be updated automatically.

To check the state of GPS assist data

MENU button →  **2** → **[GPS Settings]** → **[Use GPS Assist Data]**

Notes

- The computer is required to connect to the Internet when updating data.
- If the term of validity of assist data has run out, the time until you can record location information cannot be shortened. It is recommended that you update the assist data regularly. The expiration date of the assist data is about 30 days.
- If [Date/Time Setup] is not set, or set time is shifted greatly, the time for the GPS acquiring location information cannot be shortened.
- The assist data service may be closed for various reasons.

To update the GPS assist data by inserting a memory card into the computer

Start up [GPS Support Tool] from the main screen of the “PlayMemories Home,” select the memory card drive from your computer, and then update the GPS assist data. Insert the memory card that has been updated into the camera.

GPS Auto Time Cor.

Your camera maintains correct clock time by using GPS to acquire time information during starting up. The time is corrected when the power is turned off.

MENU button →  **2** → **[GPS Settings]** → **[GPS Auto Time Cor.]**
→ **[On]**

Notes

- [GPS Auto Time Cor.] is invalid if [GPS On/Off] is set to [Off].

- You must set [Date/Time Setup] on the camera before using it.
- There may be discrepancies of a few seconds.
- Depending on the area, it may not function correctly.

Registering your own settings

You can register 3 combinations of frequently used modes and settings in the memory. You can recall the registered settings with the mode dial.



1 Put the camera on the setting you want to register.

2 MENU button →  4 → [Memory]

3 Select the number you want to register with ◀/▶ on the multi-selector, then press the center of the multi-selector.

You can change the settings after you have registered them.

Items that can be registered

Exposure mode, aperture, shutter speed, drive mode, focus mode, ISO, white balance, exposure compensation, metering mode, DRO/Auto HDR, Creative Style, flash mode, flash compensation, Face Detection, Smile Detection Sensitivity, object tracking, Picture Effect, the position of the local AF area, and all of the  Still shooting menu items (page 37),  Movie shooting menu items (page 39)

To recall the saved settings

Set the mode dial to the desired number 1/2/3 you want to recall.

To change the saved settings

After recalling the setting, put the camera on the setting you want to register, then register the setting on the same number again.

Notes

- You cannot register the Program Shift and Manual Shift settings.
- The actual setting will not correspond to the positions of the dials on the camera. Refer to the information displayed on the LCD screen when you take pictures.

Resetting to the default

You can reset the main functions of the camera.

MENU button →  **4** → **[Initialize]** → **Select the desired setting**
→ **[OK]**

✓ : The items to be reset.

– : The items not to be reset.

Shooting functions				
Items	Reset to	Reset Default	Rec mode reset	Custom reset
Exposure compensation (106)	±0.0	✓	✓	–
Drive mode (110)	Single Shooting	✓	✓	–
Flash Mode (115)	Fill-flash (differs depending on the exposure mode)	✓	✓	–
Focus Mode (91)	Single-shot AF	✓	✓	–
AF area (95)	Wide	✓	✓	–
Object Tracking (95)	Off (differs depending on [Focus Mode])	✓	✓	–
Smile/Face Detect. (141, 145)	On (Regist. Faces)	✓	✓	–
Auto Port. Framing (143)	Off	✓	✓	–
ISO (124)	AUTO	✓	✓	–
Metering Mode (109)	Multi segment	✓	✓	–
Flash Comp. (120)	±0.0	✓	✓	–
White Balance (133)	AWB (Auto white balance)	✓	✓	–
C.Temp./Filter (134)	5500K, Color Filter 0	✓	✓	–
Custom white balance (135)	5500K	✓	✓	–
DRO/Auto HDR (126)	D-Range Optimizer: Auto	✓	✓	–
Creative Style (130)	1/Standard	✓	✓	–

Picture Effect (129)	Off	✓	✓	–
Scene Selection (71)	Portrait	✓	✓	–
Movie (153)	P	✓	✓	–
Auto Mode (69)	Intelligent Auto	✓	✓	–
Tele-zoom Cont. Priority AE (76)	T10	✓	✓	–
Still shooting menu				
Items	Reset to	Reset Default	Rec mode reset	Custom reset
Image Size (137)	L:24M	✓	✓	–
Aspect Ratio (139)	3:2	✓	✓	–
Quality (139)	Fine	✓	✓	–
Panorama: Size (137)	Standard	✓	✓	–
Panorama: Direction (75)	Right	✓	✓	–
Clear Image Zoom (149)	On	✓	✓	–
Digital Zoom (149)	Off	✓	✓	–
Long Exposure NR (150)	On	✓	✓	–
High ISO NR (150)	Normal	✓	✓	–
Flash control (121)	ADI flash	✓	✓	–
AF Illuminator (100)	Auto	✓	✓	–
SteadyShot (60)	On	✓	✓	–
AF drive speed (38)	Fast	✓	✓	–
Color Space (151)	sRGB	✓	✓	–
 Silent Controller (33)	Focus Mode	✓	✓	–
Exposure step (38)	0.3 EV	✓	✓	–
Priority setup (38)	AF	✓	✓	–
AF w/ shutter (38)	On	✓	✓	–
AEL w/ shutter (38)	On	✓	✓	–

Movie shooting menu				
Items	Reset to	Reset Default	Rec mode reset	Custom reset
File Format (155)	AVCHD	✓	✓	–
Record Setting (155)	60i 17M(FH), 50i 17M(FH)	✓	✓	–
SteadyShot (60)	Off	✓	✓	–
AF Tracking Duration (153)	Mid	✓	✓	–
Auto Slow Shutter (154)	On	✓	✓	–
 Silent Controller (33)	Audio Rec Level	✓	✓	–
Audio Recording (159)	On	✓	✓	–
Wind Noise Reduct. (159)	Off	✓	✓	–
Audio Level Display (157)	On	✓	✓	–
Audio Output Timing (158)	Live	✓	✓	–
Custom menu				
Items	Reset to	Reset Default	Rec mode reset	Custom reset
Eye-Start AF (40)	Off	✓	–	✓
FINDER/LCD Setting (179)	Auto	✓	–	✓
Red Eye Reduction (40)	Off	✓	–	✓
Release w/o Lens (175)	Disable	✓	–	✓
S. Auto Cont. Shooting (70)	Auto	✓	–	✓
S. Auto Image Extract. (70)	Auto	✓	–	✓
Grid Line (175)	Off	✓	–	✓
Auto Review (175)	2 Sec	✓	–	✓

DISP Button(Monitor) (87)	For viewfinder/No Disp. Info./Level/Histogram	✓	-	✓
DISP Button(Finder) (87)	No Disp. Info./Level/Histogram	✓	-	✓
AF RANGE Button (41, 98)	AF Range Control	✓	-	✓
AF Range Control Assist (41)	On	✓	-	✓
Peaking Level (102)	Off	✓	-	✓
Peaking Color (103)	White	✓	-	✓
Live View Display (89)	Setting Effect ON	✓	-	✓
Func. of AEL button (176)	AEL hold	✓	-	✓
ISO Button (176)	ISO	✓	-	✓
AF/MF button (176)	AF/MF Control Hold	✓	-	✓
Custom button (177)	FEL Lock toggle	✓	-	✓
Preview Button (176)	Aperture Preview	✓	-	✓
Smart Telecon. Button (103, 147)	Smart Telecon.	✓	-	✓
Focus Hold Button (42)	Focus Hold	✓	-	✓
MOVIE Button (42)	Always	✓	-	✓
Ctrl dial setup (42)	 SS  F/no.	✓	-	✓
Dial exp.comp (107)	Off	✓	-	✓
Exp.comp.set (43)	Ambient&flash	✓	-	✓
Bracket order (43)	0 → - → +	✓	-	✓
Lens Comp.: Shading (181)	Auto	✓	-	✓
Lens Comp.: Chro. Aber. (181)	Auto	✓	-	✓
Lens Comp.: Distortion (181)	Off	✓	-	✓
Front Curtain Shutter (177)	On	✓	-	✓

Face Priority Tracking (97)	On	✓	–	✓
Playback menu				
Items	Reset to	Reset Default	Rec mode reset	Custom reset
Still/Movie Select (160)	Folder View(Still)	✓	–	–
Slide Show – Repeat (163)	Off	✓	–	–
Slide Show – Interval (163)	3 sec	✓	–	–
Slide Show – Image Type (163)	All	✓	–	–
Image Index (161)	4 Images	✓	–	–
Specify Printing – Date Imprint (168)	Off	✓	–	–
Select Playback Media (160)	Slot 1	✓	–	–
Volume Settings (44)	4	✓	–	–
Playback Display (164)	Auto Rotate	✓	–	–
Memory Card Tool menu				
Items	Reset to	Reset Default	Rec mode reset	Custom reset
Select Recording Media (52)	Slot 1	✓	–	–
Recording Mode (182)	Standard	✓	–	–
File Number (183)	Series	✓	–	–
Folder Name (183)	Standard Form	✓	–	–
Clock setup menu				
Items	Reset to	Reset Default	Rec mode reset	Custom reset
Date/Time Setup (58)	–	✓	–	–
Area Setting (58)	–	✓	–	–

Setup menu				
Items	Reset to	Reset Default	Rec mode reset	Custom reset
Menu start (45)	Top	✓	–	–
Delete confirm. (45)	“Cancel” first	✓	–	–
Mode Dial Guide (45)	Off	✓	–	–
LCD Brightness (177)	Auto	✓	–	–
Viewfinder Bright. (178)	Auto	✓	–	–
Viewfinder Color Temp. (45)	0	✓	–	–
GPS Settings – GPS On/Off (187) (SLT-A99V only)	Off	✓	–	–
GPS Settings – GPS Auto Time Cor. (188) (SLT-A99V only)	–	✓	–	–
Power Save (178)	Standard	✓	–	–
Power Saving Start Time (179)	1 Min	✓	–	–
HDMI Resolution (46)	Auto	✓	–	–
CTRL FOR HDMI (46)	On	✓	–	–
HDMI Info. Display (173)	On	✓	–	–
Upload Settings (185)	On	✓	–	–
USB Connection (204)	Auto	✓	–	–
USB LUN Setting (204)	Multi	✓	–	–
Audio signals (46)	On	✓	–	–
APS-C Size Capture (179)	Auto	✓	–	–

AF Micro Adj. – AF Adjustment Setting (101)	Off*	✓	–	–
Demo Mode (47)	Off	✓	–	–
Others				
Items	Reset to	Reset Default	Rec mode reset	Custom reset
Recording information display (LCD screen) (87)	For viewfinder	✓	–	–
Recording information display (Viewfinder) (87)	Level	✓	–	–
Playback display (165)	Single-image screen (with recording information)	✓	–	–

* Even if you reset the setting, the values adjusted are not reset.

Confirming the software version

Displays the software version of your camera. Confirm the version when a firmware update is released.

If you mount a lens compatible with the lens version up feature, the version of the lens is indicated.

MENU button →  **4** → [Version]

Note

- An update can be performed only when the battery level is  (3 remaining battery icons) or more. We recommend that you use a sufficiently charged battery pack or the AC-PW10AM AC Adaptor (sold separately).

Using the software

Following applications are contained on the CD-ROM (supplied) to allow more versatile use of images shot with your camera.

- “Image Data Converter”
- “PlayMemories Home”
- “Remote Camera Control”

For detailed notes on installation, also see pages 202, 203.

Using “Image Data Converter”

With “Image Data Converter” you can do things such as the following:

- Open and edit images recorded in RAW format with various corrections, such as tone curve, and sharpness.
- Adjust images with white balance, exposure, and creative style, etc.
- Save the images displayed and edited on a computer.

You can either save the image as RAW format or save it in the general file format.

- Display and compare RAW/JPEG images recorded with this camera.
- Rate the images on a scale of 5.
- Set color labels.

To use “Image Data Converter,” refer to Help.

Click [Start] → [All Programs] → [Image Data Converter] → [Help] → [Image Data Converter Ver.4].

“Image Data Converter” support page (English only)

<http://www.sony.co.jp/ids-se/>

Using “PlayMemories Home”

With “PlayMemories Home” you can do things such as the following:

- Set images shot with the camera and display them on the computer.
- Organize images on the computer on a calendar by shooting date to view them.
- Retouch (red-eye reduction, etc.), print, send still images as e-mail attachments, and change the shooting date.
- Edit images on the computer, such as trimming, resizing.

- Print or save still images with the date.
- Create Blu-ray discs or DVD discs from AVCHD movies imported to a computer. (An Internet connection environment is required when a Blu-ray disc/DVD disc is created for the first time.)

Notes

- “PlayMemories Home” is not compatible with Mac computers. When you play back images on Mac computers, use the appropriate application software supplied with the Mac computer.
- Movies recorded with the [60p 28M(PS)]/[50p 28M(PS)], [60i 24M(FX)]/[50i 24M(FX)] or [24p 24M(FX)]/[25p 24M(FX)] setting in [Record Setting] are converted by “PlayMemories Home” in order to create an AVCHD recording disc. This conversion can take a long time. Also, you cannot create a disc with the original image quality. If you want to keep the original image quality, you must store your movies on a Blu-ray disc.

To use “PlayMemories Home,” refer to “PlayMemories Home Help Guide.”

Double-click the shortcut of  (PlayMemories Home Help Guide) on the desktop. Or, click [Start] → [All Programs] → [PlayMemories Home] → [PlayMemories Home Help Guide].

“PlayMemories Home” support page (English only)

<http://www.sony.co.jp/pmh-se/>

Using “Remote Camera Control”

Connect the camera to your computer. With “Remote Camera Control” you can:

- Set up the camera or record an image from the computer.
- Record an image directly to the computer.
- Perform an Interval Timer Shooting.

Set up the following before use: MENU button →  3 → [USB Connection] → [PC Remote]

To use “Remote Camera Control,” refer to Help.

Click [Start] → [All Programs] → [Remote Camera Control] → [Help] → [Remote Camera Control Ver.3].

Note

- In Interval Timer Shooting, the drive mode is set to [Single Shooting]. If the focus is not achieved, the shutter is not released (except when the manual focus is selected or [Priority setup] in the  Still shooting menu is set to [Release]).

Recommended computer environment (Windows)

The following computer environment is recommended when using the supplied software and importing images via a USB connection.

OS (pre-installed)	Microsoft Windows XP* SP3/Windows Vista** SP2/ Windows 7 SP1
“PlayMemories Home”	CPU: Intel Pentium III 800 MHz or faster (For playing/editing the High Definition movies: Intel Core Duo 1.66 GHz or faster/Intel Core 2 Duo 1.66 GHz or faster, Intel Core 2 Duo 2.26 GHz or faster (AVC HD (FX/FH)), Intel Core 2 Duo 2.40 GHz or faster (AVC HD (PS))) Memory: Windows XP 512MB or more (1 GB or more is recommended), Windows Vista/Windows 7 1 GB or more Hard Disk: Disk space required for installation-approximately 500 MB Display: Screen resolution-1024 × 768 dots or more
“Image Data Converter Ver.4”/ “Remote Camera Control Ver.3”	CPU/Memory: Pentium 4 or faster/1 GB or more Display: 1024 × 768 dots or more

* 64-bit editions and Starter (Edition) are not supported. Windows Image Mastering API (IMAPI) Ver.2.0 or later is required to use the function for creating discs.

** Starter (Edition) is not supported.

Recommended computer environment (Mac)

The following computer environment is recommended when using the supplied software and importing images via a USB connection.

OS (pre-installed)	USB Connection: Mac OS X v10.3 – v10.8 “Image Data Converter Ver.4” “Remote Camera Control Ver.3”: Mac OS X v10.5 – v10.8
“Image Data Converter Ver.4”/ “Remote Camera Control Ver.3”	CPU: Intel Core Solo/Core Duo/Core 2 Duo or faster Memory: 1 GB or more is recommended. Display: 1024 × 768 dots or more

Notes

- Operation is not assured in an environment based on an upgrade of the operating systems described above or in a multi-boot environment.
- If you connect 2 or more USB devices to a single computer at the same time, some devices, including the camera, may not operate, depending on the types of USB devices you are using.
- Connecting the camera using a USB interface that is compatible with Hi-Speed USB (USB 2.0 compliant) allows advanced transfer (high speed transfer), as the camera is compatible with Hi-Speed USB (USB 2.0 compliant).
- When your computer resumes activity from suspend or sleep mode, communication between the camera and your computer may not recover at the same time.

Installing the software (Windows)

Log on as Administrator.

1 Turn on your computer, and insert the CD-ROM (supplied) into the CD-ROM drive.

The installation menu screen appears.

- If it does not appear, double-click [Computer] (For Windows XP: [My Computer]) →  (PMHOME) → [Install.exe].
- If the AutoPlay screen appears, select “Run Install.exe” and follow the instructions that appear on the screen to proceed with the installation.

2 Click [Install].

Make sure that “Image Data Converter” and “PlayMemories Home” are checked and follow the instructions on the screen.

- Connect the camera to the computer by following the instructions on the screen (page 205).
- When the restarting confirmation message appears, restart the computer following the instructions on the screen.
- DirectX may be installed depending on the system environment of your computer.

3 Remove the CD-ROM after the installation is complete.

The following software is installed and shortcut icons appear on the desktop.

“Image Data Converter”

“Remote Camera Control”

“PlayMemories Home”

“PlayMemories Home Help Guide”

Note

- If “PMB” (Picture Motion Browser) supplied with a camera that was purchased before 2011 has already been installed on the computer, “PMB” will be overwritten by “PlayMemories Home,” and you may be unable to use some functions of “PMB.”

Installing the software (Mac)

Log on as Administrator.

1 Turn on your Mac computer, and insert the CD-ROM (supplied) into the CD-ROM drive.

2 Double-click the CD-ROM icon.

3 Copy the [IDC_INST.pkg] and [RCC_INST.pkg] files in the [MAC] folder to the hard disk icon.

4 Double-click the [IDC_INST.pkg] and [RCC_INST.pkg] files in the copy-to folder.

Follow the instructions on the screen to complete the installation.

Connecting the camera to the computer

Setting the USB connection

Selects the method used for a USB connection when the camera is connected to a computer or a USB device with a USB cable.

MENU button → **3** → **[USB Connection]** → **Select the desired setting**

Auto	Establishes a Mass Storage or MTP connection automatically, in accordance with a computer or other USB devices to be connected. Windows 7 computers are connected in MTP, and its unique functions are enabled to use.
Mass Storage	Establishes a Mass Storage connection between the camera, a computer, and other USB devices. Standard mode.
MTP	Establishes an MTP connection between the camera, a computer, and other USB devices. Windows 7 computers are connected in MTP, and its unique functions are enabled to use. In the case of other computers (Windows Vista/XP, Mac OS X), the AutoPlay Wizard appears, and the still images in the recording folder on the camera are imported to the computer.
PC Remote	Controls the camera from the computer using "Remote Camera Control" on the CD-ROM (supplied), such as shooting, storing images on the computer.

Notes

- When this item is set to [Auto], it may take some time to establish a connection.
 - If Device Stage* is not displayed with Windows 7, set this item to [Auto].
- * Device Stage is a menu screen used to manage connected devices, such as a camera (Function of Windows 7).

Setting the LUN (Logical Unit Number) (USB LUN Setting)

In USB communication with the computer, you can select the available slot between both the slots and slot 1.

MENU button → **3** → **[USB LUN Setting]** → **Select the desired setting**

Multi	Displays both the images in the memory card slot 1 and the memory card slot 2 on the screen of the computer.
Single	Displays only the images in the memory card slot 1 on the screen of the computer.

Connecting to the computer

1 Insert a sufficiently charged battery pack into the camera, or connect the camera to a wall outlet (wall socket) using the AC-PW10AM AC Adaptor (sold separately).

2 Turn on the camera and the computer.

3 Check that **[USB Connection]** in **3** is set to **[Mass Storage]**.

4 Connect the camera to your computer.

- When a USB connection is established for the first time, your computer automatically runs a program to recognize the camera. Wait for a while.

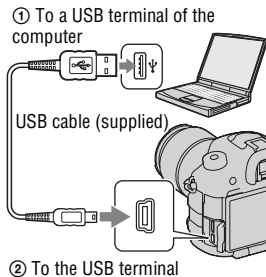

Importing images to the computer (Windows)

“PlayMemories Home” allows you to easily import images.

For details on “PlayMemories Home” functions, see the “PlayMemories Home Help Guide.”

Importing images to the computer without using “PlayMemories Home”

When the AutoPlay Wizard appears after making a USB connection between the camera and a computer, click [Open folder to view files] → [OK] → [DCIM] or [MP_ROOT] → copy the desired images to the computer.

File name

Folder	The type of file	File name
DCIM folder	JPEG file	DSC0□□□□.JPG
	JPEG file (Adobe RGB)	_DSC□□□□.JPG
	RAW file	DSC0□□□□.ARW
	RAW file (Adobe RGB)	_DSC□□□□.ARW
MP_ROOT folder	MP4 file (1440 × 1080 12M)	MAH0□□□□.MP4
	MP4 file (VGA 3M)	MAQ0□□□□.MP4

- (file number) stands for any number within the range of 0001 to 9999.
- When [Quality] is set to [RAW & JPEG], the numerical portions of the name of a RAW data file and its corresponding JPEG file are the same.

Notes

- For operations such as importing AVCHD movies to the computer, use “PlayMemories Home.”
- If you want to import movies with GPS location information to a computer, use “PlayMemories Home” (SLT-A99V only).
- When the camera is connected to the computer, if you operate AVCHD movies or folders from the connected computer, images may be damaged or cannot be played. Do not delete or copy AVCHD movies on the memory card from the computer. Sony is not held liable for consequences resulting from such operations via the computer.

Importing images to the computer (Mac)

- 1** Connect the camera to your Mac computer first. Double-click the newly recognized icon on the desktop → the folder where the images you want to import are stored.

2 Drag and drop the image files to the hard disk icon.

The image files are copied to the hard disk.

3 Double-click the hard disk icon → the desired image file in the folder containing the copied files.

The image is displayed.

The software for Mac computers

For details on other software for Mac computers, access the following URL:



<http://www.sony.co.jp/imsoft/Mac/>

Disconnecting the camera from the computer

Perform the procedures from step 1 to 2 below before:

- Disconnecting the USB cable.
- Removing the memory card.
- Turning off the camera.

1 Double-click the disconnect icon on the task bar.

- For Windows 7, click , then click .

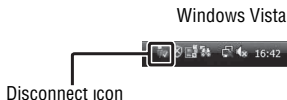

2 Click (Safely remove USB Mass Storage Device).

Notes

- Drag and drop the icon of the memory card or the drive icon to the “Trash” icon beforehand when you use a Mac computer, and the camera is disconnected from the computer.
- With Windows 7, the disconnect icon may not be displayed. In such cases, you can disconnect without following the above procedure.
- Do not disconnect the USB cable when the access lamp is lit. The data may be damaged.

Creating a movie disc



You can create a disc from AVCHD movies recorded on the camera.

Selecting the method for creating a disc of movies

You can create a disc from AVCHD movies that have been recorded with this camera.

Depending on the disc type, playable devices may vary. Select the method that suits your disc player.

There are two ways to create a movie disc. Use “PlayMemories Home” on your computer or create a disc with devices other than a computer such as a recorder.

Disc type/usage	Record setting available			Player
	PS	FX	FH	
 To keep high-definition image quality (HD)	✓	✓	✓	Blu-ray disc playback devices (Sony Blu-ray disc player, PlayStation@3, etc.)
 To keep high-definition image quality (HD) (AVCHD recording disc)	—*	—*	✓	AVCHD format playback devices (Sony Blu-ray disc player, PlayStation@3, etc.)
 To keep standard definition image quality (STD)	—*	—*	—*	Ordinary DVD playback devices (DVD player, computer that can play DVDs, etc.)

* Movies recorded with the [60p 28M(PS)]/[50p 28M(PS)], [60i 24M(FX)]/[50i 24M(FX)] or [24p 24M(FX)]/[25p 24M(FX)] setting in [Record Setting] are converted by “PlayMemories Home” in order to create an AVCHD recording disc. This conversion can take a long time. Also, you cannot create a disc with the original image quality. If you want to keep the original image quality, you must store your movies on a Blu-ray disc (page 210).

Note

- You cannot create discs of movies that were recorded with [PAL/NTSC Selector] set to [NTSC] using “PlayMemories Home.” Create discs with a device other than a computer (page 211). (Only for 1080i 50i-compatible models)

Creating a high definition image quality (HD) disc (AVCHD recording disc)

You can create a high definition image quality (HD) AVCHD recording disc from AVCHD movies imported to a computer using the supplied software “PlayMemories Home.”

1 Start up [PlayMemories Home] and click  (Create Discs).

2 Select [AVCHD (HD)] from the drop-down list used for selecting a disc.

3 Select the AVCHD movies you want to write.

4 Click [Add].

- You can also add movies by a drag and drop operation.

5 Create the disc following the instruction on the screen.

Notes

- Install “PlayMemories Home” beforehand.
- Still images and MP4 movie files cannot be recorded on the AVCHD recording disc.
- It may take a long time to create a disc.

Playing back AVCHD recording disc on a computer

You can play back the discs using “PlayMemories Home.” Select the DVD drive that hold the disc and click [Player for AVCHD] on “PlayMemories Home.”

See “PlayMemories Home Help Guide” for details.

Note

- Movies may not be played smoothly depending on the computer environment.

Creating a Blu-ray disc

You can create a Blu-ray disc with AVCHD movies previously imported to a computer. Your computer must support the creation of Blu-ray discs. BD-R (non-rewritable) and BD-RE (rewritable) media can be used to create Blu-ray discs. You cannot add contents to either type of disc once it has been created.

To create Blu-ray discs with “PlayMemories Home,” you have to install proprietary add-on software. For details, access the following URL:

<http://support.d-imaging.sony.co.jp/BDUW/>

An Internet connection environment is required to install the software. See “PlayMemories Home Help Guide” for details.

Note

- When movies recorded with the [60p 28M(PS)]/[50p 28M(PS)] setting are copied to a Blu-ray disc using “PlayMemories Home,” those movies can be played back only on devices that are compatible with the AVCHD Ver 2.0 format.

Creating a standard definition image quality (STD) disc

1 Start up [PlayMemories Home] and click  (Create Discs).

2 Select [DVD-Video (STD)] from the drop-down list used for selecting a disc.

3 Select the AVCHD movies you want to write.

4 Click [Add].

- You can also add movies by a drag and drop operation.
-

5 Create the disc following the instruction on the screen.

Notes

- Install “PlayMemories Home” beforehand.
- MP4 movie files cannot be recorded on a disc.
- It will take a longer time to create a disc because AVCHD movies are converted to standard definition image quality (STD) movies.

- An Internet connection environment is required when creating a DVD-Video (STD) disc for the first time.

Discs you can use with “PlayMemories Home”









You can use 12 cm discs of following type with “PlayMemories Home.”
For Blu-ray disc, see page 210.

Disc type	Features
DVD-R/DVD+R/DVD+R DL	Unrewritable
DVD-RW/DVD+RW	Rewritable

- Always maintain your PlayStation®3 to use the latest version of the PlayStation®3 system software.
- The PlayStation®3 may not be available in some countries/regions.

Creating a disc with a device other than a computer

You can create a disc with a Blu-ray disc recorder etc.
The disc type you can create depends on the device used.

Device	Disc type		
 <p>Blu-ray disc recorder: To create a Blu-ray disc or DVD with standard image quality (STD)</p>	<table border="1"> <tr> <td>  High-definition image quality (HD) </td> <td>  Standard definition image quality (STD) </td> </tr> </table>	 High-definition image quality (HD)	 Standard definition image quality (STD)
 High-definition image quality (HD)	 Standard definition image quality (STD)		
 <p>HDD recorder, etc.: To create a DVD with standard image quality (STD)</p>	 Standard definition image quality (STD)		

Notes

- For details on how to create a disc, refer to the operating instructions of the device you use.
- To copy movies recorded with the [60p 28M(PS)]/[50p 28M(PS)] setting to a Blu-ray disc, a device compatible with the AVCHD Ver 2.0 format is required. To play back the created Blu-ray disc, a device compatible with the AVCHD Ver 2.0 format is required.

Troubleshooting

If you experience trouble with your camera, try the following solutions.

❶ Check the items on pages 212 to 220.

❷ Remove the battery pack, and insert the battery pack again after about 1 minute, and turn on the power.

❸ Reset the settings (page 191).

❹ Consult your Sony dealer or local authorized Sony service facility.

Battery pack and power

The battery pack cannot be installed.

- As you insert the battery pack, use the tip of the battery pack to push the lock lever (page 51).
- You can use an NP-FM500H battery pack only. Make sure that the battery is NP-FM500H.

The remaining battery level indicator shows incorrect level or power runs out quickly despite the indicator showing sufficient battery level. The camera will not turn on.

- This phenomenon occurs when you use the camera in an extremely hot or cold location (page 227).
- The battery pack is discharged. Install a charged battery pack (page 49).
- The battery pack is dead (page 237). Replace it with a new one.
- Install the battery pack correctly (page 51).

The power turns off suddenly.

- If you do not operate the camera for given period of time, the camera turns to power saving mode and nearly shuts down. To cancel the power save, operate the camera, such as pressing the shutter button halfway down (page 178).

The CHARGE lamp flashes when charging the battery pack.

- You can use an NP-FM500H battery pack only. Make sure that the battery is NP-FM500H.
- If you charge a battery pack that has not been used for a long time, the CHARGE lamp may flash.
- The CHARGE lamp flashes in 2 ways, fast (about 0.15-second intervals) and slow (about 1.5-second intervals). If it is flashing fast, remove the battery pack and reattach the same battery pack securely. If the CHARGE lamp flashes fast again, it suggests that there is something wrong with the battery pack. Slow flashing indicates that charging is suspended because the ambient temperature is outside the suitable range for charging the battery pack. Charging will resume and the CHARGE lamp will be lit when the ambient temperature returns to within the suitable temperature. The optimal temperature for charging the battery pack is between 10°C and 30°C (50°F and 86°F).

Shooting images

Nothing is displayed on the LCD screen in viewfinder mode when the power is turned on.

- [FINDER/LCD Setting] is set to [Manual]. Press the FINDER/LCD button (page 179).

The image is not clear in the viewfinder.

- Adjust the diopter scale properly using the diopter-adjustment dial (page 17).

No images in the viewfinder.

- [FINDER/LCD Setting] is set to [Manual]. Press the FINDER/LCD button (page 179).
- Move your eye a little closer to the viewfinder.

The shutter does not release.

- You are using a memory card with a write-protect switch, and the switch is set to the LOCK position. Set the switch to the recording position.
- Check the free capacity of the memory card.

- In autofocus mode, the shutter cannot be released when the subject is out of focus.
- The lens is not attached properly. Attach the lens properly (page 55).
- When the camera is attached to another device, such as an astronomical telescope, set [Release w/o Lens] to [Enable] (page 175).
- The subject may require special focusing (page 93). Use the focus-lock or manual focus function (pages 94, 101).

Recording takes a long time.

- The noise reduction function is turned on (page 150). This is not a malfunction.
- You are shooting in RAW mode (page 139). Since the RAW data file is large, the RAW mode shooting may take time.
- The Auto HDR is processing an image (page 127).

The same image is shot several times.

- The drive mode is set to [Cont. Shooting] or [Bracket: Cont.]. Set it to [Single Shooting] (page 110).
- The exposure mode is set to Tele-zoom Continuous Priority AE (page 76).
- The exposure mode is set to Superior Auto and [S. Auto Image Extract.] is set to [Off] (page 70).

The image is out of focus.

- The subject is too close. Check the minimum focal distance of the lens.
- You are shooting in manual focus mode. Set [Focus Mode] to other than [DMF], [Manual Focus] (page 91).
- When the focus mode switch is equipped with the lens, set it to AF.
- Ambient light is insufficient.

Eye-Start AF does not work.

- Set [Eye-Start AF] to [On] (page 40).
- Press the shutter button halfway down.

The date and time are recorded incorrectly.

- Set the correct date and time (page 58).
- The area selected with [Area Setting] is different from the actual area. Set up [Area Setting] again (page 58).

The aperture value and/or shutter speed flashes when you press the shutter button halfway down.

- Since the subject is too bright or too dark, it is beyond the available range of the camera. Adjust the setting again.

The image is whitish (Flare).**Blurring of light appears on the image (Ghosting).**

- The picture was taken under a strong light source, and excessive light has entered the lens. Attach a lens hood.

The corners of the picture are too dark.

- If any filter or hood is used, take it off and try shooting again. Depending on the thickness of the filter and improper attachment of the hood, the filter or the hood may partially appear in the image. The optical properties of some lenses may cause the periphery of the image to appear too dark (insufficient light). You may compensate for this phenomenon with [Lens Comp.: Shading] (page 181).

The eyes of the subject come out red.

- Activate the red eye reduction function (page 40).
- Get close to the subject, and shoot the subject within the flash range using the flash. Check the flash range in “Specifications.”

Dots appear and remain on the LCD screen.

- This is not a malfunction. These dots are not recorded (page 12).

The image is blurred.

- The picture was taken in a dark location without the flash, resulting in camera shake. The use of a tripod or the flash is recommended (page 115).

The EV scale ◀ ▶ is flashing on the LCD screen or in the viewfinder.

- The subject is too bright or too dark for the metering range of the camera.

The sound is not recorded properly.

- If you set the recording level to the minimum, the sound is not recorded.
- If you set the recording level to the maximum, the sound tends to include cracking noises.

Viewing images

Your camera cannot play back images.

- The folder/file name has been changed on your computer (page 205).
- When an image file has been processed by a computer or when the image file was recorded using a model other than that of your camera, playback on your camera is not guaranteed.
- Use “PlayMemories Home” to play images stored on a PC with this camera.
- The camera is in USB mode. Disconnect the camera from the computer (page 207).

Deleting images

Your camera cannot delete an image.

- Cancel the protection (page 167).

You have deleted an image by mistake.

- Once you have deleted an image, you cannot restore it. We recommend that you protect images that you do not want to delete (page 167).

GPS (SLT-A99V only)

The camera is not receiving a GPS signal.

- Set [GPS On/Off] to [On] (page 187).
- Your camera may not be able to receive radio signals from GPS satellites because of obstructions.
- To triangulate the location information correctly, bring your camera to an open area, and turn on the camera again.
- When you attach accessories (sold separately) to the camera, the GPS signal from GPS satellites may not be as strong as before you attached the accessory.

Excessive error in location information.

- The margin of error can be up to several-hundred meters depending on surrounding buildings, weak GPS signals, etc.

It takes time to triangulate although GPS assist data has been taken in.

- [Date/Time Setup] is not set, or set time is shifted greatly. Set the date and time correctly (page 58).

- The term of validity of assist data has expired. Update the GPS assist data (page 188).
- As the positions of GPS satellites vary constantly, it may take longer to determine the location or the receiver may not be able to determine the location at all, depending on the location and time you use the camera.
- “GPS” is a system for determining geographic location by triangulating radio signals from GPS satellites. Avoid using the camera in places where radio signals are blocked or reflected, such as a shadowy place surrounded by buildings or trees, etc. Use the camera in open sky environments.

The location information has not been recorded.

- Use “PlayMemories Home” to import the movies with GPS location information to your computer.

Computers

You do not know if the OS of your computer is compatible with the camera.

- Check “Recommended computer environment” (page 201).

Your computer does not recognize your camera.

- Check that the camera is turned on.
- When the battery level is low, install the charged battery pack (page 49), or use the AC Adaptor (sold separately).
- Use the USB cable (supplied) (page 205).
- Disconnect the USB cable, and connect it again firmly.
- Disconnect all equipment other than the camera, the keyboard and the mouse from the USB jacks of your computer.
- Connect the camera directly to your computer without passing through a USB hub or other devices (page 205).

You cannot copy images.

- Make the USB connection by properly connecting the camera with your computer (page 205).
- Follow the designated copy procedure for your OS (pages 205, 206).
- When you shoot images with a memory card formatted by a computer, you may not be able to copy the images to a computer. Shoot using a memory card formatted by your camera (page 183).

The image cannot be played back on a computer.

- If you are using “PlayMemories Home,” refer to the “PlayMemories Home Help Guide.”
- Consult the computer or software manufacturer.

After making a USB connection, “PlayMemories Home” does not start automatically.

- Make the USB connection after the computer is turned on (page 205).

Memory card

Cannot insert a memory card.

- Insertion direction of the memory card is wrong. Insert it in the correct direction (page 51).

Cannot record on a memory card.

- The memory card is full. Delete unnecessary images (pages 67, 170).
- An incompatible memory card is inserted (pages 54, 234).
- Select the slot in which the memory card is installed using [Select Recording Media] (page 52).

Cannot play back files on a memory card.

- Check the setting of [Select Playback Media] (page 160).

You have formatted a memory card by mistake.

- All the data on the memory card are deleted by formatting. You cannot restore it.

Printing

Cannot print images.

- RAW images cannot be printed. To print RAW images, first convert them to JPEG images using “Image Data Converter” on the supplied CD-ROM.

The color of the image is strange.

- When you print the images recorded in Adobe RGB mode using sRGB printers that are not compatible with Adobe RGB (DCF2.0/Exif2.21), the images are printed at a lower intensity level (page 151).

Images are printed with both edges cut off.

- Depending on your printer, the left, right, top, and bottom edges of the image may be cut off. Especially when you print an image shot with the aspect ratio set to [16:9], the lateral end of the image may be cut off.
- When printing images on your printer, cancel the trimming or borderless settings. Consult the printer manufacturer as to whether the printer provides these functions or not.
- When having images printed at a digital print shop, ask the shop whether they can print the images without cutting off both edges.

Cannot print images with the date.

- Using “PlayMemories Home,” you can print images with date (page 199).
- When you print images at a shop, images can be printed with the date if you ask them to do so.

Others

The lens gets fogged.

- Moisture condensation has occurred. Turn off the camera and leave it for about 1 hour before using it (page 227).

The message “Set Area/Date/Time.” appears when you turn on the camera.

- The camera has been left unused for sometime with a low battery or no battery pack. Charge the battery pack and set the date again (pages 58, 227). If the date setting is lost every time the battery pack is charged, consult your Sony dealer or local authorized Sony service facility.

The number of recordable images does not decrease or decreases 2 at a time.

- This is because the compression rate and the image size after compression change depending on the image when you shoot a JPEG image (page 139).

The setting is reset without the resetting operation.

- The battery pack was removed when the power switch was set to ON. When removing the battery pack, make sure the camera is turned off and the access lamp is not lit (pages 18, 53).

The camera does not work properly.

- Turn off the camera. Remove the battery pack and insert it again. If the camera is warm, remove the battery pack, and allow it to cool down before trying this corrective procedure.
- If an AC Adaptor (sold separately) is used, disconnect the power plug. Connect the power plug and turn on the camera again. If the camera does not work after trying these solutions, consult your Sony dealer or local authorized Sony service facility.

 **appears on the screen.**

- The SteadyShot function does not work. You can continue to shoot but the SteadyShot function will not work. Turn the camera off and on. If the SteadyShot scale continues to appear, consult your Sony dealer or local authorized Sony service facility.

“--E-” appears on the screen.

- Remove the memory card, and insert it again. If this procedure does not turn off the indication, format the memory card.

Warning messages

If the following messages appear, follow the instructions below.

Set Area/Date/Time.

- Set the area, date, and time. If you have not used the camera for a long time, charge the internal rechargeable battery (pages 58, 227).

Power insufficient.

- You tried to perform [Cleaning Mode] when the battery level is insufficient. Charge the battery pack or use the AC Adaptor (sold separately).

Unable to use memory card. Format?

- The memory card was formatted on a computer and the file format was modified. Select [Enter], then format the memory card. You can use the memory card again, however, all previous data in the memory card is erased. It may take a some time to complete the format. If the message still appears, change the memory card.

Memory Card Error

- An incompatible memory card is inserted or the format has failed.

Reinsert memory card.

- The inserted memory card cannot be used in your camera.
- The memory card is damaged.
- The terminal section of the memory card is dirty.

Memory card locked.

- You are using a memory card with a write-protect switch, and the switch is set to the LOCK position. Set the switch to the recording position.

Processing...

- When Long exposure noise reduction or High ISO noise reduction will be done for the same amount of time that the shutter was open. You cannot do any further shooting during this reduction.

Unable to display.

- Images recorded with other cameras or images modified with a computer may not be displayed.

Check the lens attachment. If the lens is not supported, you can permit use of the lens in the custom menu.

- The lens is not attached properly, or the lens is not attached.
- When attaching the camera to an astronomical telescope or something similar, set [Release w/o Lens] to [Enable].

Unable to print.

- You tried to mark RAW images with a DPOF mark.

Internal temp. high. Allow it to cool.

- The camera has become hot because you have been shooting continuously.
Turn the power off. Cool the camera and wait until the camera is ready to shoot again.



- Because you have been recording for a long time, the temperature inside the camera has increased to an unacceptable level. Stop recording.

Recording is unavailable in this movie format.

- Set [File Format] to [MP4].



- The number of images exceeds that for which date management in a database file by the camera is possible.



- Unable to register to the database file. Import all the images to a computer using “PlayMemories Home” and recover the memory card.

**Camera Error
System Error**

- Turn the power off, remove the battery pack, then re-insert it. If the message appears frequently, consult your Sony dealer or local authorized Sony service facility.

Image Database File error. Recover?

- You cannot record or play back AVCHD movies because the Image Database File is damaged. Follow the on-screen instructions to recover data.

**Unable to magnify.
Unable to rotate image.**

- Images recorded with other cameras may not be magnified or rotated.

Cannot create more folders.

- The folder with a name beginning with “999” exists on the memory card. You cannot create any folders if this is the case.

Cleaning the camera and a lens

Cleaning the camera

- Do not touch the inside of the camera, such as lens contacts, or the mirror. Since dust on the mirror or around the mirror may affect the images or the performance of the camera, blow the dust away using a commercially available blower*. For details on cleaning the image sensor, see page 224.
* Do not use a spray blower. Using one may cause a malfunction.
- Clean the camera surface with a soft cloth slightly moistened with water, then wipe the surface with a dry cloth. To avoid damaging the finish or casing, follow the instructions below.
 - Do not use chemical products such as thinner, benzine, alcohol, disposable cloths, insect repellent, sunscreen or insecticide, etc.
 - Do not touch the camera with the above on your hand.
 - Do not leave the camera in contact with rubber or vinyl for a long time.

Cleaning the lens

- Do not use a cleaning solution containing organic solvents, such as thinner, or benzine.
- When cleaning the lens surface, remove dust using a commercially available blower. In case of dust that sticks to the surface, wipe it off with a soft cloth or tissue paper slightly moistened with lens cleaning solution. Wipe in a spiral pattern from the center to the outside. Do not spray lens cleaning solution directly onto the lens surface.

Cleaning the image sensor

If dust or debris enters the camera and adheres to the image sensor (the part that converts the light to an electric signal), it may appear as dark spots on the photo image, depending on the shooting environment. If there is dust on the image sensor, follow the steps below to clean the sensor.

Notes

- Cleaning cannot be performed when the battery level is 50% or less.
- The camera starts beeping if the battery level becomes low during cleaning. Stop cleaning immediately and turn the camera off. The use of an AC-PW10AM AC Adaptor (sold separately) is recommended.
- The cleaning should be completed quickly.
- Do not use a spray blower because it may scatter water droplets inside the camera body.

Cleaning the image sensor automatically using the cleaning mode of the camera

1 Confirm that the battery is fully charged (page 53).

2 MENU button →  4 → [Cleaning Mode]

3 Select [Enter] with ▲ on the multi-selector, and press the center of the multi-selector.

The image sensor vibrates for a short time, and eliminates dust from the sensor.

4 Turn off the camera.

Cleaning the image sensor using a blower

If further cleaning is needed after using the cleaning mode, the image sensor can be cleaned with the blower by following the steps below.

1 Perform the cleaning operation described in steps 1 to 3 of “Cleaning the image sensor automatically using the cleaning mode of the camera.”

2 Detach the lens (page 56).

3 Push the mirror lock lever with a finger to lift up the mirror.

- Be careful not to touch the surface of the mirror.

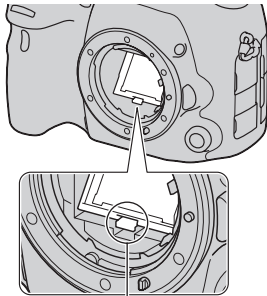

Mirror lock lever

4 Use the blower to clean the image sensor surface and the surrounding area.

- Do not touch the image sensor with the tip of the blower and do not put the tip of a blower into the cavity beyond the mount.
- Hold the camera's face downward to prevent the dust from resettling in the camera. Complete the cleaning quickly.
- Also clean the back of the mirror using a blower.

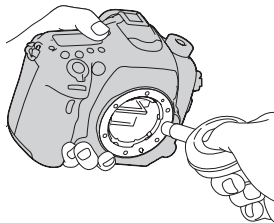

5 After the cleaning is finished, lower the mirror with a finger until it clicks.

- Lower the frame of the mirror back down with a finger. Be careful not to touch the surface of the mirror.
- Lower the mirror down until it locks firmly.

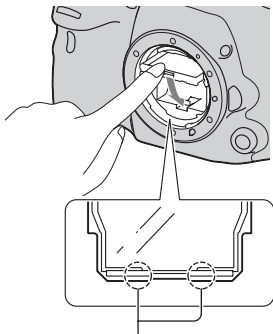

Put either of the sides down.

6 Attach the lens and turn the camera off.

- Confirm that the mirror is locked down firmly when you attach the lens.

Notes

- After the cleaning is finished, confirm that the mirror is locked down firmly when you attach the lens. Failure to lock the mirror may result in lens scratching or other troubles. Also, if the mirror is not locked down firmly, the autofocus does not work during shooting.
- You cannot shoot while the mirror is lifted up.

Precautions

Do not use/store the camera in the following places

- In an extremely hot, dry or humid place
In places such as in a car parked in the sun, the camera body may become deformed and this may cause a malfunction.
- Storing under direct sunlight or near a heater
The camera body may become discolored or deformed, and this may cause a malfunction.
- In a location subject to rocking vibration
- Near strong magnetic place
- In sandy or dusty places
Be careful not to let sand or dust get into the camera. This may cause the camera to malfunction, and in some cases this malfunction cannot be repaired.
- Humid places
Mold may grow on the lens in such places.

On storing

Be sure to attach the front lens cap or body cap when not using the camera. When attaching the body cap, remove all the dust from the cap before placing it on the camera.

On operating temperatures

Your camera is designed for use under the temperatures between 0°C

and 40°C (32°F and 104°F). Shooting in extremely cold or hot places that exceed this range is not recommended.

On moisture condensation

If the camera is brought directly from a cold to a warm location, moisture may condense inside or outside the camera. This moisture condensation may cause a malfunction of the camera.

How to prevent moisture condensation

When bringing the camera from a cold place to a warm place, seal the camera in a plastic bag and allow it to adapt to conditions at the new location over about 1 hour.

If moisture condensation occurs

Turn off the camera and wait about an hour for the moisture to evaporate. Note that if you attempt to shoot with moisture remaining inside the lens, you will be unable to record clear images.

On the internal rechargeable battery

This camera has an internal rechargeable battery for maintaining the date and time and other settings regardless of whether the power is on or off, or the battery pack is charged or discharged.

This rechargeable battery is continually charged as long as you are using the camera. However, if you use the camera for only short periods,

it gradually discharges. If you do not use the camera at all for about 3 months it becomes completely discharged. In this case, be sure to charge this rechargeable battery before using the camera.

However, even if this rechargeable battery is not charged, you can still use the camera as long as you do not record the date and time. If the camera resets the settings to the defaults each time you charge the battery, the internal rechargeable battery may be dead. Consult your Sony dealer or local authorized Sony service facility.

Charging method of the internal rechargeable battery

Insert a charged battery pack in the camera, or connect the camera to a wall outlet (wall socket) using the AC Adaptor (sold separately), and leave the camera for 24 hours or more with the power off.

On using the lenses and accessories

It is recommended that you use Sony lenses/accessories (including Konica Minolta products) designed to suit the characteristics of this camera. Using the products of other manufacturers may cause the camera not to operate to its capability, or result in accidents and malfunctions of the camera.

On memory cards

Do not attach a label, etc. on a memory card or a card adaptor. This may cause a malfunction.

Note on disposal/transfer of the camera

When you dispose of or transfer the camera, perform the following operations to protect personal information:

- [Initialize] → [Reset Default] (page 191)
- Delete all the face registration data (page 142).

On recording/playback

- When you use a memory card with this camera for the first time, it is recommended to format the card using the camera for stable performance of the memory card before shooting. Note that formatting permanently erases all data on the memory card, and is unrecoverable. Save precious data on a computer, etc.
- If you repeatedly record/delete images, fragmentation of data may occur on the memory card. Movies may not be able to be saved or recorded. In such a case, save your images to a computer or other storage location, then format the memory card (page 183).
- Before you record one-time events, make a trial recording to make sure that the camera is working correctly.

- This camera is designed to be dust- and moisture-resistant but not to be waterproof and splash-proof. When using the camera in the rain, be careful not to get the camera and lens wet. Clean the camera after use if the camera becomes dirty. With water, sand, dust, salt, etc., left on the camera, the camera may cause a malfunction.
- Do not look at the sun or a strong light through a removed lens or the viewfinder. This may cause irrecoverable damage to your eyes. Or it may cause a malfunction of your camera.
- Do not use the camera near a location that generates strong radio waves or emits radiation. The camera may not be able to record or play back properly.
- Using the camera in sandy or dusty locations may cause malfunctions.
- If moisture condensation occurs, remove it before using the camera (page 227).
- Do not shake or strike the camera. In addition to malfunctions and an inability to record images, this may render the memory card unusable, or cause image data breakdown, damage or loss.
- Keep the camera, supplied accessories, etc., out of the reach of children. A memory card, etc., may be swallowed. If such a problem occurs, consult a doctor immediately.

To use your camera abroad — Power sources

You can use your camera and the battery charger and the AC-PW10AM AC Adaptor (sold separately) in any country or region where the power supply is within 100 V to 240 V AC, 50/60 Hz.

Note

- Do not use an electronic transformer (travel converter), as this may cause a malfunction.

On TV color systems

When you view images on a TV screen, the camera and TV must use the same TV color system.

NTSC system

Bahama Islands, Bolivia, Canada, Central America, Chile, Colombia, Ecuador, Jamaica, Japan, Korea, Mexico, Peru, Surinam, Taiwan, the Philippines, the U.S.A., Venezuela, etc.

PAL system

Australia, Austria, Belgium, China, Croatia, Czech Republic, Denmark, Finland, Germany, Holland, Hong Kong, Hungary, Indonesia, Italy, Kuwait, Malaysia, New Zealand, Norway, Poland, Portugal, Rumania, Singapore, Slovak Republic, Spain, Sweden, Switzerland, Thailand,

Turkey, United Kingdom, Viet Nam, etc.

PAL-M system

Brazil

PAL-N system

Argentina, Paraguay, Uruguay

SECAM system

Bulgaria, France, Greece, Guiana, Iran, Iraq, Monaco, Russia, Ukraine, etc.

AVCHD format

The AVCHD format is a high definition digital video camera format used to record a high definition (HD) signal of either the 1080i specification*¹ or the 720p specification*² using efficient data compression coding technology. The MPEG-4 AVC/H.264 format is adopted to compress video data, and the Dolby Digital or Linear PCM system is used to compress audio data.

The MPEG-4 AVC/H.264 format is capable of compressing images at higher efficiency than that of the conventional image compressing format. The MPEG-4 AVC/H.264 format enables a high definition video signal shot on a digital video camera recorder to be recorded on 8 cm DVD discs, hard disk drive, flash memory, memory card, etc.

Recording and playback on your camera

Based on the AVCHD format, your camera records with the high definition image quality (HD) mentioned below.

Video signal*³:

1080 60i-compatible device

MPEG-4 AVC/H.264 1920 × 1080/60i, 1920 × 1080/60p, 1920 × 1080/24p

1080 50i-compatible device

MPEG-4 AVC/H.264 1920 ×

1080/50i, 1920 × 1080/50p, 1920 × 1080/25p

Audio signal: Dolby Digital 2ch
Recording media: Memory card

*1 1080i specification

A high definition specification which utilizes 1,080 effective scanning lines and the interlace system.

*2 720p specification

A high definition specification which utilizes 720 effective scanning lines and the progressive system.

*3 Data recorded in AVCHD format other than the above mentioned cannot be played on your camera.

GPS (SLT-A99V only)

This system allows you to pinpoint your exact location on the earth. The GPS satellites are located in 6 orbits, 20,000 km above the earth. The GPS system consists of 24 or more GPS satellites. A GPS receiver receives radio signals from the satellites, and calculates the current location of the receiver based on the orbital information (almanac data) and travel time of the signals, etc.

Determining a location is called “triangulation.” A GPS receiver can determine the location’s latitude and longitude by receiving signals from 3 or more satellites.

- As the positions of GPS satellites vary constantly, it may take longer to determine the location or the receiver may not be able to determine the location at all, depending on the location and time you use the camera.
- “GPS” is a system for determining geographic location by triangulating radio signals from GPS satellites. Avoid using the GPS feature on your camera in places where radio signals are blocked or reflected, such as a shadowy place surrounded by buildings or trees, etc. Use the camera in open sky environments.
- You may not be able to record location information at locations or in situations where radio signals

from the GPS satellites do not reach the camera as follows.

- In tunnels, indoors or under the shade of buildings.
- Between tall buildings or at narrow streets surrounded by buildings.
- In underground locations, locations surrounded by dense trees, under an elevated bridge, or in locations where magnetic fields are generated, such as near high voltage cables.
- Near devices that generate radio signals of the same frequency band as the camera: near 1.5 GHz band mobile telephones, etc.
- If you publish or share images that were recorded with [GPS On/Off] set to [On] on the Internet, the location information of the images may be exposed to third parties. In such cases, set [GPS On/Off] to [Off] before shooting (page 187).

On triangulating errors

- If you move to another location right after turning on the camera, it may take a longer time for the camera to start triangulating, compared to when you stay in the same place.
- Error caused by the position of GPS satellites
The camera automatically triangulates your current location when the camera receives radio signals from 3 or more GPS satellites. The triangulating error allowed by the GPS satellites is about 30 m (98 feet). Depending on

the environment of the location, the triangulating error can be greater. In this case, your actual location may not match the location on the map based on the GPS information. Meanwhile, the GPS satellites are controlled by the United States Department of Defense, and the degree of accuracy may be changed intentionally.

- Error during the triangulation process
The camera acquires location information every about 15 seconds during triangulation. There is a slight time lag between when the location information is acquired and when the location information is recorded on an image, therefore, the actual recording location may not match exactly the location on the map based on the GPS information.

On the restriction of use of GPS on an airplane

During take off and landing of an airplane, turn off the camera, as you will be instructed to do by the on-board announcement.

On the other restriction

Use GPS in accordance with the regulations of the place or situation.

On the geographic coordinate system

The “WGS-84” geographic coordinate system is used.

Memory card

Notes on using memory cards

- Do not strike, bend or drop the memory card.
- Do not use or store the memory card under the following conditions:
 - High temperature locations such as the hot interior of a car parked in direct sunlight.
 - Locations exposed to direct sunlight.
 - Humid locations or locations with corrosive substances present.
- The memory card may be hot just after it has been used for a long time. Be careful when you handle it.
- When the access lamp is lit, do not remove the memory card or the battery pack, or turn off the power. The data may be corrupted.
- Data may be damaged if you place the memory card near strongly-magnetized material or use the memory card in a static-prone or electrically noisy environment.
- We recommend backing up important data, such as to a hard disk of a computer.
- When you carry or store the memory card, put it in the case supplied with it.
- Do not expose the memory card to water.
- Do not touch the terminal section of the memory card with your hand or a metal object.
- When the write-protect switch of a memory card is set to the LOCK position, you cannot perform operations, such as recording or deleting images.
- The memory cards formatted with a computer are not guaranteed to operate with this camera. Be sure to format the memory cards using the camera.
- Data read/write speeds differ depending on the combination of the memory cards and the equipment used.
- Do not press down hard when you write down on the memo area.
- Do not attach a label on the memory cards themselves.
- Do not disassemble or modify the memory cards.
- Do not leave the memory cards within the reach of small children. They might accidentally swallow it.

Notes on the “Memory Stick” media used with the camera

The types of “Memory Stick” media that can be used with this camera are as follows. However, proper operation cannot be guaranteed for all “Memory Stick PRO Duo” media functions.

“Memory Stick PRO Duo”**media***1*2*3**“Memory Stick PRO-HG Duo”****media***1*2

Compatible with your camera

**“Memory Stick Duo” media**

Not compatible with your camera

**“Memory Stick” media and “Memory Stick PRO” media**

Not compatible with your camera



- *1 This is equipped with MagicGate function. MagicGate is copyright protection technology that uses encryption technology. Data recording/playback that requires MagicGate functions cannot be performed with this camera.
- *2 Supports high-speed data transfer using a parallel interface.
- *3 When using “Memory Stick PRO Duo” media to record movies, only those marked with Mark2 can be used.

Notes on using “Memory Stick Micro” media (sold separately)

- This product is compatible with “Memory Stick Micro” media (“M2”). “M2” is an abbreviation for “Memory Stick Micro” media.
- To use a “Memory Stick Micro” media with the camera, be sure to insert the “Memory Stick Micro” media into an “M2” Adaptor as large as Duo size. If you insert a “Memory Stick Micro” media into the camera without an “M2” Adaptor as large as Duo size, you might not be able to remove it from the camera.
- Do not leave the “Memory Stick Micro” media within the reach of small children. They might accidentally swallow it.

Battery pack/ Battery charger

- The charging time differs depending on the remaining capacity of the battery pack or charging conditions.
- We recommend charging the battery pack in an ambient temperature of between 10 to 30°C (50 to 86°F). You may not be able to efficiently charge the battery pack outside of this temperature range.
- Connect the battery charger to the nearest wall outlet (wall socket).
- Do not try to charge the battery pack again right after it has been charged, or when it has not been used after being charged. Doing so will affect the performance of the battery pack.
- Do not charge any battery pack other than the “InfoLITHIUM” M series battery pack in the battery charger (supplied) with your camera. Batteries other than the specified kind may leak, overheat, or explode if you attempt to charge them, posing a risk of injury from electrocution and burns.
- When the CHARGE lamp flashes, this may indicate a battery error or that a battery pack other than the specified type has been installed. Check that the battery pack is the specified type. If the battery pack is the specified type, remove the battery pack, replace it with a new

one or another one and check if the battery charger operates correctly. If the battery charger operates correctly, a battery error may have occurred.

- If the battery charger is dirty, charging may not be performed successfully. Clean the battery charger with dry cloth, etc.

Notes on using the battery pack

- Use only an NP-FM500H battery pack. Note that the NP-FM55H, NP-FM50 and NP-FM30 cannot be used.
- The displayed battery power level may not be correct under certain circumstances.
- Do not expose the battery pack to water. The battery pack is not water-resistant.
- Do not leave the battery pack in extremely hot places, such as in a car or under direct sunlight.

Effective use of the battery pack

- Battery performance decreases in low temperature environments. So, the time that the battery pack can be used is shorter in cold places and the speed of continuous shooting slows down. We recommend that you put the battery pack in a pocket close to your body to warm it up, and insert it in your camera immediately before you start shooting.

- The battery pack will run out quickly if you use the flash frequently, use continuous shooting often, turn the camera on and off frequently, or set the LCD screen brighter.

Battery life

- The battery life is limited. Battery capacity decreases little by little as you use it more and more, and as time passes. If the battery operating time seems shortened considerably, a probable cause is that the battery pack has reached the end of its life. Buy a new battery pack.
- The battery life varies according to how it is stored and the operating conditions and environment in which each battery pack is used.

How to store the battery pack

In order to prolong battery life, you should charge the battery and fully use it up at least once a year. When storing the battery pack, be sure to keep it in a dry, cool place.

The License

Notes on the License

This camera comes with software that are used based on license agreements with their owners of copyright. Based on requests by the owners of copyright of these software applications, we have an obligation to inform you of the following. Please read the following sections. Read licenses (in English) in the "License" folder on the CD-ROM.

THIS PRODUCT IS LICENSED UNDER THE AVC PATENT PORTFOLIO LICENSE FOR THE PERSONAL AND NON-COMMERCIAL USE OF A CONSUMER TO

(i) ENCODE VIDEO IN COMPLIANCE WITH THE AVC STANDARD ("AVC VIDEO")

AND/OR

(ii) DECODE AVC VIDEO THAT WAS ENCODED BY A CONSUMER ENGAGED IN A PERSONAL AND NON-COMMERCIAL ACTIVITY AND/OR WAS OBTAINED FROM A VIDEO PROVIDER LICENSED TO PROVIDE AVC VIDEO.

NO LICENSE IS GRANTED OR SHALL BE IMPLIED FOR ANY OTHER USE.

ADDITIONAL INFORMATION MAY BE OBTAINED FROM MPEG LA, L.L.C.

SEE

[HTTP://WWW.MPEGLA.COM](http://www.mpegla.com)

238

On GNU GPL/LGPL applied software

The software that is eligible for the following GNU General Public License (hereinafter referred to as "GPL") or GNU Lesser General Public License (hereinafter referred to as "LGPL") are included in the camera.

This informs you that you have a right to have access to, modify, and redistribute source code for these software programs under the conditions of the supplied GPL/LGPL.

Source code is provided on the web. Use the following URL to download it.

<http://www.sony.net/Products/Linux/>

We would prefer you do not contact us about the contents of source code.

Read licenses (in English) in the "License" folder on the CD-ROM.

To view the PDF, Adobe Reader is needed. If it is not installed on your computer, you can download it from the Adobe Systems web page:

<http://www.adobe.com/>

Index

A

- A..... 78
- ADI flash..... 121
- Adobe RGB..... 151
- AE Lock..... 108
- AEL..... 108
- AEL w/ shutter..... 38
- AF area..... 95
- AF drive speed..... 38
- AF Illuminator 100
- AF Micro Adj..... 101
- AF On 100
- AF RANGE..... 98
- AF RANGE Button..... 41, 98
- AF range control 98
- AF Range Control Assist 41
- AF Tracking Duration..... 153
- AF w/ shutter 38
- AF/MF button 105, 176
- AF/MF control 105
- AF-A 92
- AF-C 92
- AF-D 92
- AF-S..... 92
- Ambient light 43, 113
- Anti-dust function..... 56, 224
- Aperture 78
- Aperture Preview 80
- Aperture Priority 78
- APS-C Size Capture..... 179
- Area Setting..... 58
- Aspect Ratio..... 139
- Assist area 92
- Audio Level Display 157
- Audio Output Timing 158
- Audio Rec Level 157
- Audio Recording 159
- Audio signals..... 46
- AUTO..... 63
- Auto HDR 127
- Auto Mode 69
- Auto Port. Framing 143
- Auto Review 175
- Auto Slow Shutter 154
- Auto WB 133
- Autoflash 115
- Autofocus 91, 105
- Auto-lock Accessory shoe 24
- Automatic AF..... 92
- AVCHD 155
- AVCHD View..... 160

B

- Battery pack 49, 51, 236
- Bracket 112
- Bracket order..... 43
- Bracket: Cont. 112
- “BRAVIA” Sync..... 174
- BULB shooting 84

C

Center weighted.....	109
Charging battery pack.....	49
Cleaning.....	223
Cleaning Mode	224
Clear Image Zoom.....	148
Cloudy (White balance).....	133
Color filter (White balance).....	134
Color Space	151
Color temperature (White balance)	134
Compression ratio.....	139
Computer	199, 204
Continuous AF.....	92
Continuous shooting.....	76, 111
Contrast.....	132
Copy	169
Creative Style	130
Ctrl dial setup	42
CTRL FOR HDMI	46, 174
Custom (White balance).....	135
Custom button	42, 177

D

Date Imprint.....	168
Date/Time Setup.....	57
Daylight (White balance)	133
DC IN terminal	21
Default	191
Delete.....	67, 170
Delete confirm.	45
Demo Mode	47

Depth Map Assist Continuous AF	92
Dial exp.comp.....	107
Digital level gauge.....	88
Digital Zoom.....	147
Diopter-adjustment	17
Direct manual focus	104
Disc creation	208
DISP.....	87, 165
DISP Button(Finder).....	40, 87
DISP Button(Monitor).....	40, 87
Display All Info.	87
Display Card Space.....	45
Display panel	29
Display panel illumination button	29
DMF.....	104
DPOF Setup	168
D-Range Optimizer.....	126
Drive mode	110
DRO Bracket	114
DRO/Auto HDR	126

E

Enlarged image	160
EV scale	83, 106, 113
Exp.comp.set.....	43
Exposure compensation	106
Exposure mode	68
Exposure step.....	38
Extra fine	139
Eye-Fi	185

- Eyepiece cup 62
 Eyepiece sensor 17, 62
 Eye-Start AF 40
- F**
- Face Detection 141
 Face Priority Tracking 97
 Face Registration 142
 FEL lock 122
 File Format (Movie) 155
 File Number 183
 Fill-flash 115
 FINDER/LCD Setting 179
 FINE 139
 Fine 139
 Flash (White balance) 133
 Flash bracket 112
 Flash compensation 120
 Flash control 121
 Flash Exposure Level lock 122
 Flash Mode 115, 119
 Flash Off 115
 Flash sync terminal 118
 Fluor.: Cool White (White balance)
 133
 Fluor.: Day White (White balance)
 133
 Fluor.: Daylight (White balance)
 133
 Fluor.: Warm White (White
 balance) 133
 Fn 34, 35
 Focus 91
 Focus Hold 42
 Focus Hold Button 42
 Focus indicator 93
 Focus Magnifier 103
 Focus Mode 91, 101
 Focus-lock 94
 Folder Name 183
 Folder View 160
 Format 183
 Front Curtain Shutter 177
 Func. of AEL button 176
 Function button 34
- G**
- GPS 187, 232
 GPS Assist Data 188
 GPS Auto Time Cor. 188
 GPS Settings 187
 Graphic Display 88
 Grid Line 175
- H**
- Hand-held Twilight 71
 HDMI 172
 HDMI Info. Display 173
 HDMI Resolution 46, 173
 HDR Painting 129
 High Contrast Mono 129
 High ISO NR 150
 High-speed sync 116
 Histogram 89

- I**
- Image Data Converter.....199
 - Image Index161
 - Image quality139
 - Image sensor94, 224
 - Image Size137
 - In-Camera Guide48
 - Incandescent (White balance)...133
 - Initialize191
 - Install202, 203
 - Intelligent Auto.....69
 - ISO Button176
 - ISO sensitivity124, 176
- J**
- JPEG139
- L**
- Landscape71
 - Language12, 47
 - LCD Brightness177
 - LCD screen.....25, 59, 87, 165
 - Lens55
 - Lens Comp.: Chromatic Aberration
.....181
 - Lens Comp.: Distortion181
 - Lens Comp.: Peripheral Shading
.....181
 - Live View Display.....89
 - Local (AF area).....95
 - Long Exposure NR150
- M**
- M.....82
 - Macro71
 - Manual Exposure82
 - Manual focus101, 105
 - Manual shift.....83
 - Mass Storage.....204
 - Memory.....190
 - Memory card.....51, 54, 182, 234
 - Memory recall.....190
 - MENU.....37
 - Menu37
 - Menu start45
 - Metering Mode109
 - MF.....101, 105
 - Microphone jack21
 - Miniature.....129
 - Mode Dial Guide45
 - Moisture condensation.....227
 - MOVIE65, 152
 - Movie65, 152, 153
 - Movie Audio Recording159
 - MOVIE Button42, 65, 153
 - Movie File Format155
 - Movie Record Setting155
 - Movie recording.....65, 152
 - MP4.....155
 - MTP204
 - Multi frame noise reduction....124
 - Multi interface shoe19, 24
 - Multi segment109
 - Multi-selector.....17

- N**
- New Folder 184
 - Night Portrait 71
 - Night Scene 71
 - No Disp. Info. 87
 - Noise reduction 124, 150
- O**
- Object Tracking 95
 - Overexposure 165
- P**
- P 77
 - PAL/NTSC Selector 180
 - Panorama: Direction 75
 - Panorama: Size 137
 - Partial Color 129
 - PC Remote 204
 - Peaking 102
 - Peaking Color 103
 - Peaking Level 102
 - Picture Effect 129
 - Playback Display 164
 - PlayMemories Home 199
 - Pop Color 129
 - Portrait 71
 - Posterization 129
 - Power Save 178
 - Power Saving Start Time 179
 - Pre-flash TTL 121
 - Preset white balance 134
 - Pressing halfway down 63
 - Preview 80, 176
 - Preview Button 176
 - Print 168
 - Priority setup 38
 - Program Auto 77
 - Protect 167
- Q**
- Quality 139
 - Quick Navi 31
- R**
- RAW 139
 - RAW+J 139
 - Rear sync 115
 - Record Setting (Movie) 155
 - Recording Mode 182
 - Recording movies 65, 152
 - Recover Image DB 185
 - Red Eye Reduction 40
 - Reducing camera shake 60
 - Release w/o Lens 175
 - Remaining battery level 53
 - REMOTE 21
 - Remote Camera Control 200
 - Remote Commander 21, 114
 - REMOTE terminal 21
 - Reset 191
 - Retro Photo 129
 - Rich-tone Mono. 129
 - Rotate 162

S

S	80
S. Auto Cont. Shooting	70
S. Auto Image Extract.	70
Saturation	132
Scene Selection	71
SCN	71
Scroll Playback	75
Select Playback Media	160
Select REC Folder	184
Select Recording Media	52
Self-timer	111
Set the clock	57
Shade (White balance)	133
Sharpness	132
Shoe adaptor	24
Shooting	63
Shooting mode	68
Shot. Result Preview	80
Shoulder strap	21
Shutter Priority	80
Shutter speed	80
Silent Controller	33
Silent multi-controller	32
Single Bracket	112
Single Shooting	110
Single-shot AF	92
Slide Show	163
SLOW SYNC	117
Slow Sync	117
Smart teleconverter	147
Smart Zoom	147

Smile Detection Sensitivity indicator	145
Smile Shutter	145
Soft Focus	129
Soft High-key	129
Software	199
Specify Printing	168
Sports Action	71
Spot (AF area)	95
Spot (Metering Mode)	109
sRGB	151
Standard	139
STD	139
SteadyShot function	60
Still/Movie Select	160
Strap	21
Style box	130
Sunset	71
Superior Auto	69
Sweep Panorama	73

T

T10	76
T8	76
Tele-zoom Cont. Priority AE	76
Toy Camera	129
Tracking focus	95
TV	172

U

Underexposure	165
Upload Settings	185

USB.....	204
USB Connection	204
USB LUN Setting	204

V

Version.....	198
View Mode	160
Viewfinder	17
Viewfinder Bright	178
Viewing image.....	66, 160
Viewing images on a TV screen	172
Volume Settings.....	44, 66

W

WB	133
WB bracket	113
White Balance.....	133
Wide (AF area)	95
Wind Noise Reduct.	159
Wireless (Flash Mode).....	115
Wireless Remote Commander	114

X

X.FINE.....	139
-------------	-----

Z

Zone (AF area).....	95
Zoom.....	63, 147, 160