

SERVICE MANUAL

AKAI TAPE RECORDER

MODEL 1710W

TABLE OF CONTENTS

I	SPECIFICATIONS	1
II	MEASURING METHOD	2
III	LOCATION CONTROLS	4
IV	DISMANTLING OF TAPE TRANSPORT UNIT & AMPLIFIERS	5
V	TRANSPORT MECHANISM	6
VI	MECHANISM ADJUSTMENT	9
VII	AMPLIFIER ADJUSTMENT	11
VIII	MAINTENANCE PROCEDURES	12
IX	REPLACEMENT PARTS TABLE	14
X	TROUBLE SHOOTING CHART	30
XI	SCHEMATIC DIAGRAM	41

I. SPECIFICATIONS

STYLE	: Portable	MOTOR	: Condenser starting induction two-speed motor.
WEIGHT	: 33 lbs. (15 kg)	Horse Power 1/100 HP
DIMENSIONS	: 14"H x 13-1/2"W x 7-1/2"D (360H x 345W x 190D mm)	Power Ratio 70 %
POWER SUPPLY	: AC 100 to 240 V, 50/60 Hz	Revolution
RECORDING			2,900 to 1,450 r.p.m. at 50 Hz
SYSTEM	: In-line 4-track stereo, monaural recording		3,480 to 1,740 r.p.m. at 60 Hz
PLAY BACK		HEADS	
SYSTEM	: In-line 4-track stereo, monaural play back	REC/PLAY	
POWER		HEAD	: Inline 4-track stereo/monaural
CONSUMPTION	: 80 VA	Gap 4/1000 mm
TAPE SPEED	: 3 speeds . . . : 1-7/8", 3-3/4", 7-1/2" (15"with 15" adaptor kit)	Impedance 3,600 ohms at 1,000 Hz
TAPE SPEED		ERASE HEAD	: Inline 4-track stereo
DEVIATION	: Within \pm 3% at all tape speeds.	Gap 0.1 mm
WOW AND		Impedance 3,600 ohms at 90 K. Hz
FLUTTER	: Less than 0.18 % R.M.S. at 7-1/2" Less than 0.25 % R.M.S. at 3-3/4" Less than 0.35 % R.M.S. at 1-7/8"	RECORD LEVEL	
FREQUENCY		INDICATOR	: Vertical indication model "A" VU meter
RESPONSE	: 40 to 15,000 Hz \pm 3 dB at 7-1/2" 40 to 12,000 Hz \pm 3 dB at 3-3/4" 40 to 6,000 Hz \pm 3 dB at 1-7/8"	TRANSISTOR	
SIGNAL TO		USED	: 2SC650 x 2 2SC - 458LG (C,D) x 2
NOISE RATIO	: Better than 50 dB	TUBE USED	: 12AT7 x 1 6AR5 x 2 6CA4 x 1
DISTORTION		GERMANIUM	
(Total Harmonics)	: Within 3 % at 1,000 Hz 0 VU recording	USED	: IN-34A x 2
CROSS-TALK	: Less than -55 dB (Monaural) Less than -43 dB (Stereo)	REELS USED	: 7", 5", 3" reels
ERASE RATIO	: Less than -70 dB		
INSULATION			
RESISTANCE	: More than 50 M ohms.		
INSULATION			
DURABILITY	: 1,000 V. AC for more than one minute duration.		
LINE OUTPUT	: 2.5 V at volume maximum (250 Hz 0 VU recorded tape used) Impedance; 82 K. ohms		
MAIN OUTPUT	: 4 W at music power per each channel, total 8 W Impedance; 8 ohms		
DIN OUTPUT	: 2.5 V at Volume maximum Impedance; 82 K. ohms		
LINE INPUT	: 150 mV Impedance . . . 130 K. ohms		
MIC. INPUT	: 3 mV Impedance . . . 30 K. ohms		
DIN INPUT	: 20 mV Impedance . . . 36 K. ohms		
FAST FORWARD AND REWIND			
TIME	: 150 seconds for 1,200 ft. tape at 50 Hz 120 seconds for 1,200 ft. tape at 60 Hz		
MONITOR			
SYSTEM	: Can be monitored the program being recorded by using a stereo headphone.		

II. MEASURING METHOD

TAPE SPEED DEVIATION

1. Method involving use of pre-recorded tape
Playback on the tape recorder to be tested tape pre-recorded at 1,000 Hz \pm 0.1% for measuring tape speed deviation.

Connect the appropriate output to a frequency counter meter in order to measure the tape speed deviation from the resulting deviation of the measured frequency.

2. Method involving use of timing tape
(designed for tape speed measurement)

This method utilizes a timing tape marked at intervals of 7-1/2". The running time of the tape over 60 marked section is measured in order to calculate the deviation of the tape speed. In applying this method, however, it should be born in mind that the timing tape stretch or contract, measurement error is inevitable, so that it is necessary to measure the total length of the tape in advance.

WOW AND FLUTTER

Playback the 3,000 Hz pre-recorded tape whose wow and flutter level is guaranteed to be smaller than 0.07% for measurement by means of a wow meter. It is also possible for a 3,000 Hz sine wave to be recorded and played for measurement by means of the wow meter. In this case, however, the wow meter indicates a value as much as twice the value given in the specification on the first page.

SIGNAL TO NOISE RATIO

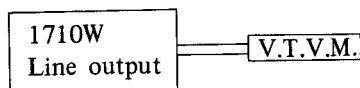

Set the Equalizer Switch on "7-1/2 ips" position and playback a tape containing a 1,000 Hz sine wave recorded at "0" VU level on a standard recorder. Connect a V.T.V.M. to the line output jack of the recorder and measure its output.

Then remove the tape and measure the noise level under the same condition. Convert each of the measured values into decibels.

TOTAL HARMONIC DISTORTION FACTOR

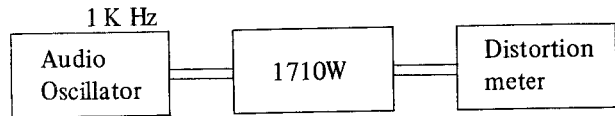

Connect the measuring instrument as shown above, and record the 1,000 Hz sine wave at "0" VU. Playback the resultant signal and measure the overall distortion factor. Measure the noise level of the tape recorder with the tape removed; connect the audio oscillator directly to the distortion meter for measurement of the distortion factor of the oscillator.

The required distortion factor may be obtained from the results of the above measurement by the following formula.

$$d_0 = d - d_1 - d_2$$

where, d_0 = Required
 d = Overall distortion factor
 d_1 = Noise level
 d_2 = Distortion factor of the oscillator

(Note: New tape of particularly good quality should be used for measurement of the distortion factor).

POWER OUTPUT

Playback a tape containing a sine wave of 1,000 Hz recorded at 0 VU on a standard recorder.

Connect a V.T.V.M. to the line output jack of the recorder and measure the voltage at the output of the recorder to be tested.

CROSS TALK (Cross talk between the tracks)

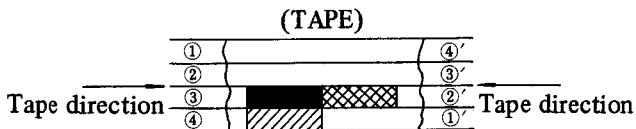

As shown in the figure, first record a 1,000 Hz sine wave on track No. 3 at +3 VU level. Next, remove the 1,000 Hz input signal and record under a non-input condition.

Then, playback the tape on track No. 3 and No. 1 (reversed condition of tape) through the 1,000 Hz B.P.F. (Band Pass Filter, Sensitivity ... 1 : 1) and obtain a ratio between the two from the following formula.

$$C = 20 \log \frac{E_0}{E_2 - E_1} \text{ (db)}$$

C = Desired cross talk ratio (db)

E_0 = 1,000 Hz signal output level

E_2 = 1,000 Hz cross talk output level

E_1 = Non-input signal record level



PLAYBACK:

- 5) Set the Record/Playback Knob in "Play" position.
- 6) Set the Equalizer Switch on 7-1/2" or 3-3/4" position.
- 7) Connect a V.T.V.M. to the Line output.
- 8) Playback the tape previously recorded.
- 9) Adjust the output level to "0" dbm at 1,000 Hz as indicated on the V.T.V.M. by the range selector of a V.T.V.M.
- 10) Playback the recorded spot frequencies with the conditions in (9); make a memo of output level and plot the value on a graph.

FREQUENCY RESPONSE

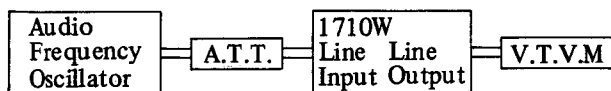

Connect the measuring instrument as in the above diagram, and measure the frequency response in the following sequence:

RECORD:

- 1) Give a sine wave of 1,000 Hz to the Line Input of the recorder to be tested through an attenuator from an audio frequency generator.
- 2) Set the Record/Playback Knob in "Rec" position and adjust the line input volume so that the VU meter needle indicates "0" VU.
- 3) Under the condition described in (2), lower the input level 10 db by means of the attenuator.
- 4) Record the spot frequency in the range of 30 Hz to 25,000 Hz from the audio frequency generator.

III. LOCATION OF CONTROLS

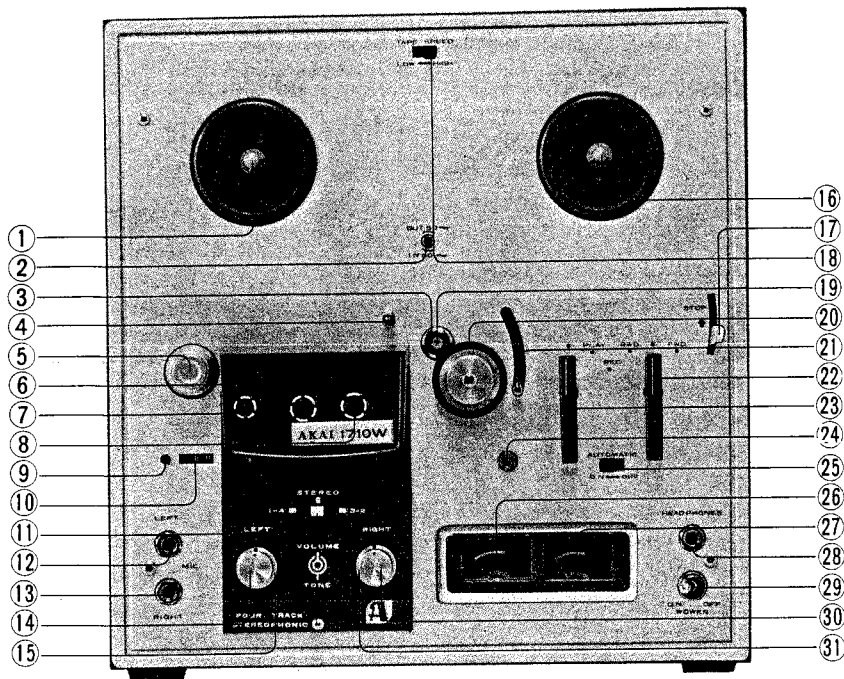

- ① Supply Reel Shaft
- ② Cycle Conversion Switch (A)
- ③ Capstan
- ④ Capstan Storage Post
- ⑤ Tape Guide
- ⑥ Erase Head
- ⑦ Tape Cleaner
- ⑧ Record/Playback Head
- ⑨ Reset Button
- ⑩ Index Counter
- ⑪ Track Selector
- ⑫ Microphone Jack (Left)
- ⑬ Microphone Jack (Right)
- ⑭ Volume Control (Left)
- ⑮ Tone Control (Left)
- ⑯ Take-up Reel Shaft
- ⑰ Pause Lever
- ⑱ Speed Change Switch
- ⑲ Capstan Shaft
- ⑳ Pinch Wheel
- ㉑ Automatic Shut-off Lever
- ㉒ Fast Forward/Rewind Knob
- ㉓ Record/Playback Button
- ㉔ Record Safety Button
- ㉕ Automatic Shut-off Switch
- ㉖ VU Meter (Left)
- ㉗ VU Meter (Right)
- ㉘ Stereo Headphone Jack
- ㉙ Power Switch
- ㉚ Volume Control (Right)
- ㉛ Tone Control (Right)
- ㉜ Voltage Selector Switch
- ㉝ Fuse Post
- ㉞ Cycle Conversion Switch (B)
- ㉟ Speaker Switch
- ㊱ External Speaker Jack (Left)
- ㊲ External Speaker Jack (Right)
- ㊳ Line Input Jack (Right)
- ㊴ Line Output Jack (Right)
- ㊵ DIN Jack
- ㊶ Line Output Jack (Left)
- ㊷ Line Input Jack (Left)

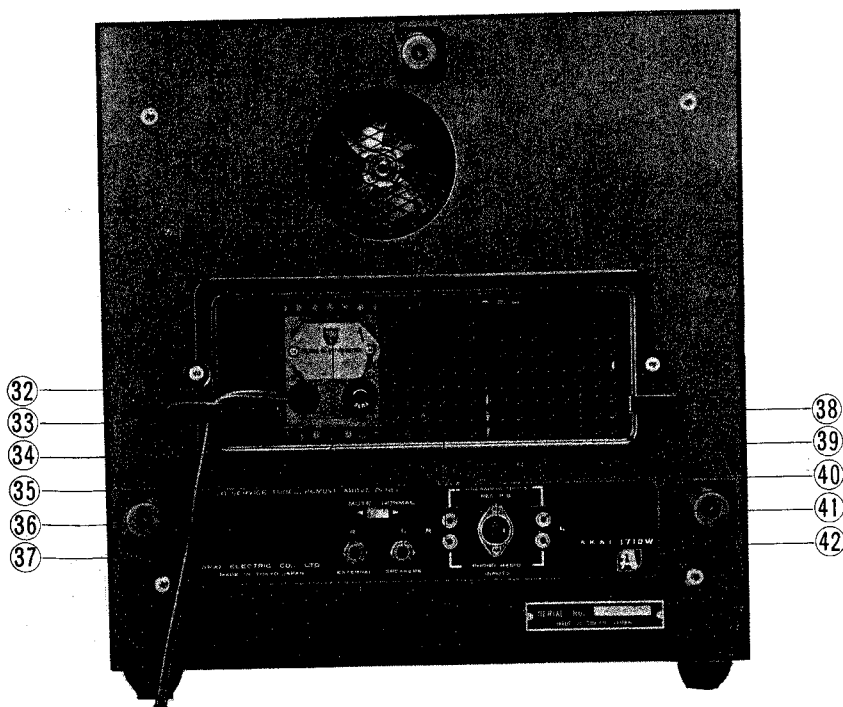

IV. DISMANTLING OF TAPE TRANSPORT UNIT & AMPLIFIERS

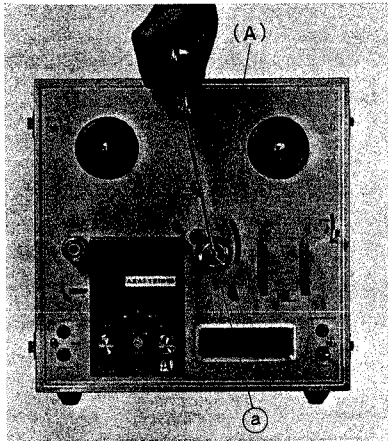

(1) Loosen the RETAINING SCREW (a) of the PINCH WHEEL (A) using a philips-headed screw driver and remove the PINCH WHEEL by hand.

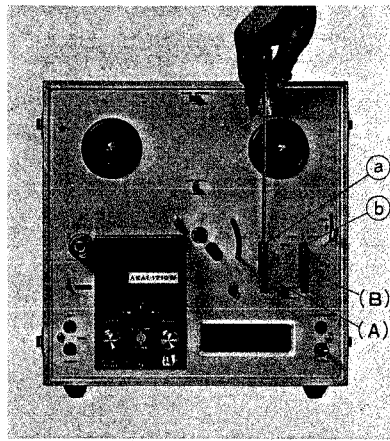

(2) Loosen the RETAINING SCREWS (a) and (b) of the DECK CONTROL KNOBS (A) and (B) by using a philips-headed screw driver and remove the KNOBS by hand.

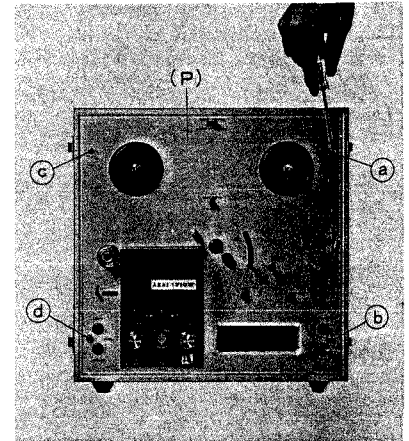

(3) Loosen the SCREWS (marked from (a) to (d)) by using a philips-headed screw driver and remove the DECK PANEL (P) by hand.

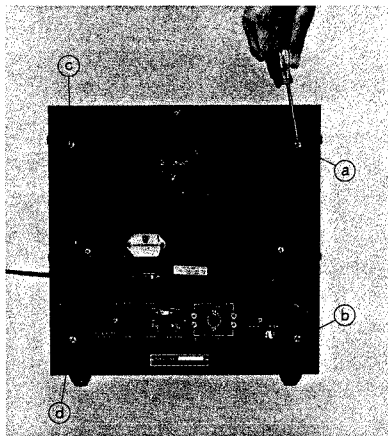

(4) Loosen the SCREWS (marked from (a) to (d)) by using a philips-headed screw driver.

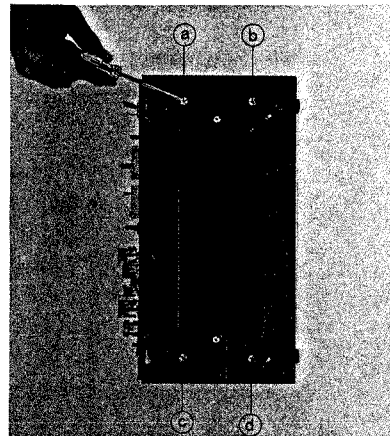

(5) Loosen the SCREWS (marked from (a) to (d)) by using a philips-headed screw driver.

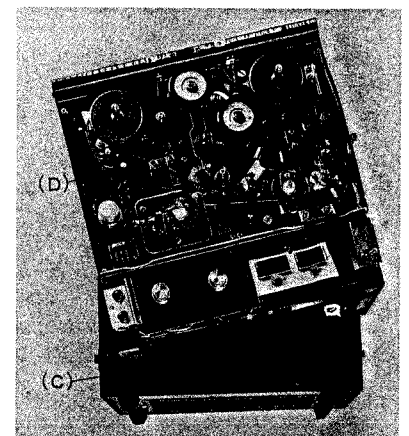

(6) Remove the TAPE TRANSPORT MECHANISM ASSEMBLY AND AMPLIFIER ASSEMBLY (D) by slowly lifting it from the CASE (C) as shown in picture.

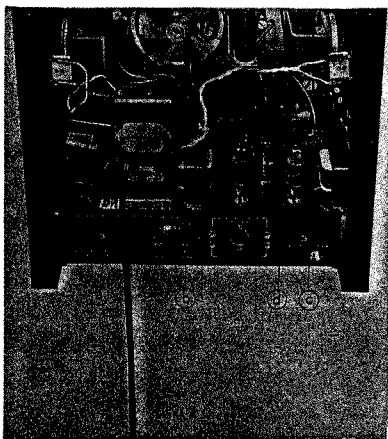

(7) Disconnect the PLUGS (marked (a) to (d)) carefully by hand.

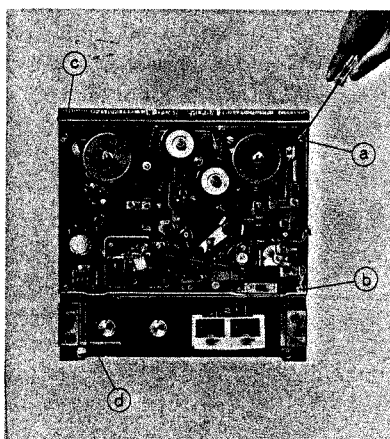

(8) Loosen the SCREWS (marked from (a) to (d)) of the DECK FRAME by using a philips-headed screw driver.

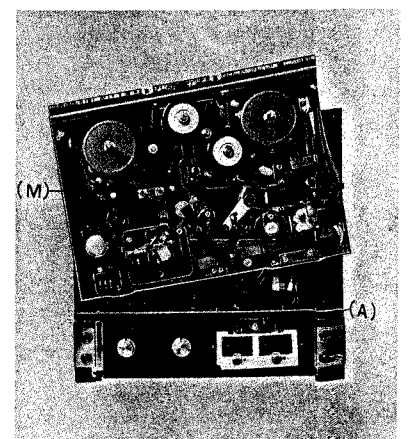

(9) Separate the TAPE TRANSPORT MECHANISM ASSEMBLY (M) from the AMPLIFIER ASSEMBLY (A) carefully by hand.

V. TRANSPORT MECHANISM

DRIVING OF CAPSTAN

Figure 1.

- (A) Motor
- (B) Driving Belt (flat belt)
- (C) Capstan
- (D) Flywheel

High-speed rotation of *Motor* (A) is reduced by *Driving Belt* (B) and transmitted to *Capstan* (C), which is connected of flywheel with ample inertia. This enables the rated rotation by absorbing minor rotation distortion of motor itself.

Capstan Rotation:

- 606 R.P.M. at 7-1/2" (19 cm) per sec.
- 303 R.P.M. at 3-3/4" (9.5 cm) per sec.
- 151.5 R.P.M. at 1-7/8" (4.75 cm) per sec.

Motor Rotation:

- 3,000 to 1,500 R.P.M. at 50 Hz
- 3,600 to 1,800 R.P.M. at 60 Hz

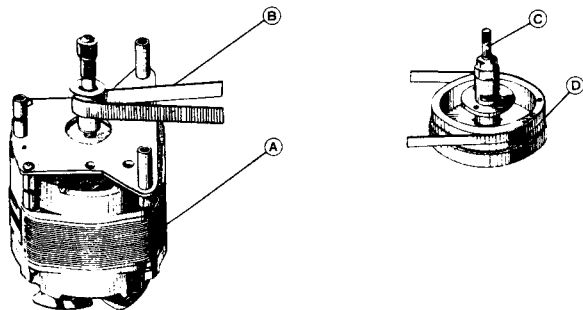

Fig. 1

DRIVING OF PINCH WHEEL

Put tape between rotating capstan and pinch wheel and push pinch wheel against capstan, this will transport the tape at rated speed. The appropriate pressure of pinch wheel is between 1,000 to 1,150 grams at the tape speed of 7-1/2" (19 cm) per second.

RECORDING AND PLAYBACK

Turn the RECORD/PLAYBACK KNOB (A) to "PLAY" position, and pinch wheel presses against capstan to move tape at the rated speed. At the same time, *Idler* (B) moves between *Motor Bushing* (C) and the *Take-Up Reel Spindle* (D) to transmit the motor rotation to (D) so that the tape is moved and wound on the take-up reel. The Take-up Reel Spindle Base is made up of two plastic rollers (1 and 2) with a clutch felt in between. The Idler is rotating the plastic roller (2) underneath. Therefore, the tape-winding friction is adjusted by the slipping of the felt to maintain rated winding of the tape. On the other hand, the *Supply Reel Spindle* (H) has a *Brake Roller* (E) hung on the Plastic Roller (4) underneath, which provides appropriate back tension by the felt clutch slipping to the rotation of the Pulley (3) above. To prevent accidental erasure, the *Record Interlock Button* (F) must be depressed before the RECORD/PLAYBACK KNOB can be moved to the "REC" position. The *Safety device* (G) is depressed to operate the recording mechanism. (See figure 2)

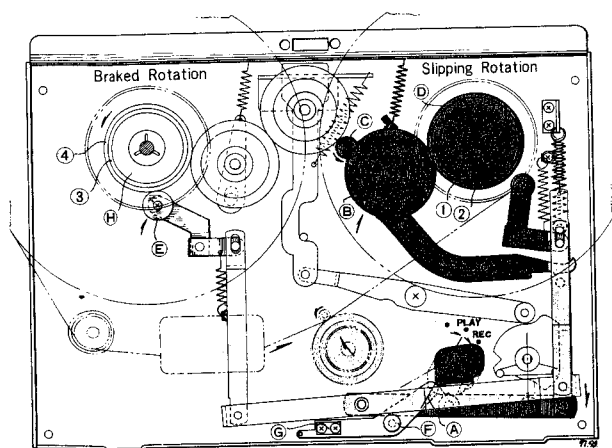

Fig. 2

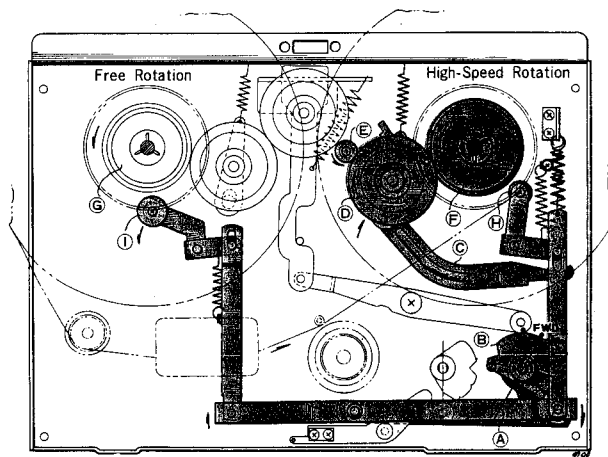

Fig. 3

FAST-FORWARD MECHANISM

Turn the *FAST FWD-REWIND knob (A)* in "FAST FWD" position, and the *cam (B)* under the knob pushes up the *Lever (C)*. The *Idler (D)* moves into the space between the *Plastic Roller (F)* above the *Take-up Reel Spindle* and the upper part of the rotating *motor drive bushing* to transmit the motor rotation to the take-up reel spindle. At the same time, *Brake Rollers (H) and (I)* come off the reel spindle to free the *Supply Reel Spindle (G)*, thereby allowing fast winding of the tape onto the take-up reel.
(See figure 3)

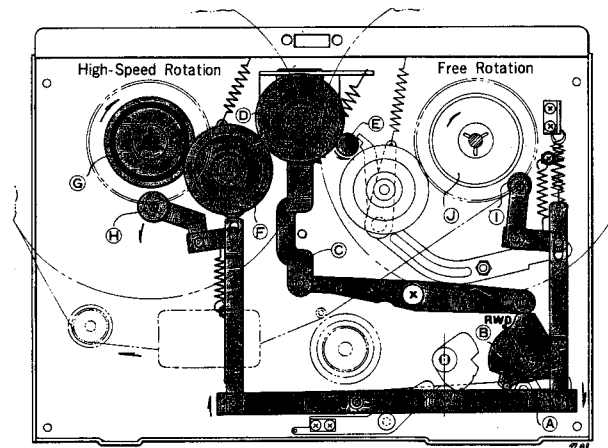

Fig. 4

REWIND MECHANISM

Turn the *FAST FWD-REWIND knob (A)* in "REWIND" position, and the *cam (B)* under the knob pushes the *Lever (C)* up. The *Idler (D)* moves into the space between the upper part of the rotating *Motor drive bushing (E)* and the *Intermediate Pulley (F)* to transmit the high-speed rotation of the motor through the intermediate pulley to the *Supply Reel Spindle (G)*. At the same time, *Brake Rollers (H) and (I)* come off the reel spindle to free the *take-up reel spindle (J)*, thereby rewinding the tape into the supply reel at a fast speed.
(See figure 4)

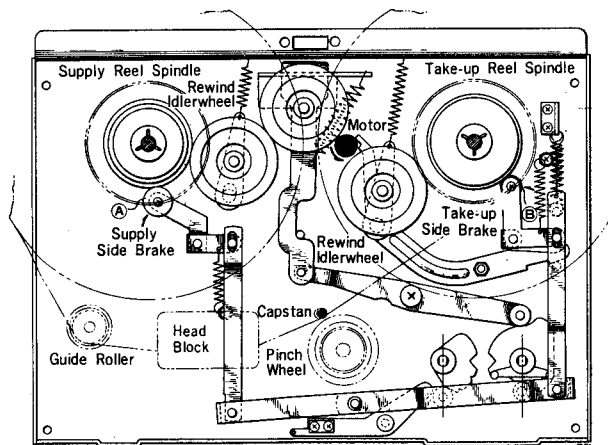

Fig. 5

STOP CONTROL

Turn the stop lever in "STOP" position, *Brake Rollers (A) and (B)* depress reel spindles to stop rotation of the reel spindles.
As the brake rubber depresses the plastic rollers under the reel spindles, no friction works on the tape itself.
(See figure 5)

Modes of Operation	Pinch Wheel	Take-up Idler Wheel	Rewind Idler Wheel	Take-up side Brake	Supply side Brake
(a) STOP	X	X	X	○	○
(b) FAST-FORWARD	X	○	X	X	X
(c) REWIND	X	X	○	X	○
(d) RECORDING PLAYBACK	○	○	X	X	X

NOTE: X - marks indicates "open" and
○ - marks "engaged"

RECORD/PLAYBACK CHANGING MECHANISM

By turning the RECORD/PLAYBACK KNOB (N) to the recording position, the CAM (a) pushes the RECORDING LEVER (b), as illustrated in dotted line. Then the LEVER (b) pulls the RECORDING LEVERS (d) and (e), which are joined with the RECORD/PLAYBACK CHANGING SWITCH (SW1) to be turned to recording position.

If the LEVERS (b), (d) and (e) are not pulled properly, the (SW1) does not operate properly, so abnormal oscillation may occur and also recording cannot take place. The LEVERS must be adjusted to proper position by loosening the SCREWS (f) and (g).

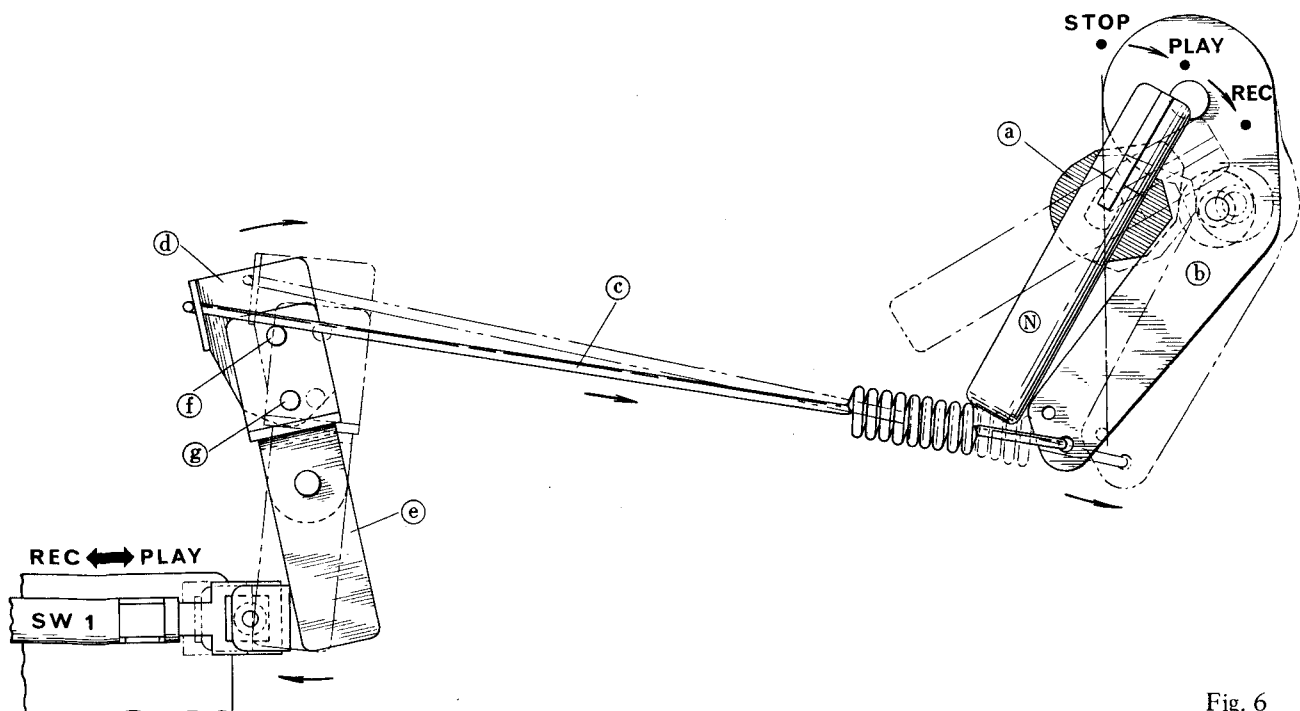

Fig. 6

VI. MECHANISM ADJUSTMENT

1. ADJUSTMENT OF PINCH WHEEL

It is important that the pinch wheel shaft is kept in complete alignment with the capstan shaft. A proper pinch wheel pressure is between 1,000 and 1,150 grams when the unit is operated at the tape speed of 7-1/2 ips. Any deviation from this specification will result in wow and flutter. Check pinch wheel pressure by a spring scale, and if necessary, adjust the pinch wheel load spring.

2. ADJUSTMENT OF TAKE-UP IDLER WHEEL

The take-up idler wheel must be kept in complete alignment with the take-up reel shaft. When the unit is set in fast forward condition, the idler wheel will contact with the upper knurled wheel of the take-up reel shaft assembly, and it will contact with the lower knurled wheel during record or play operation. Adjust idler wheel load spring so that the idler wheel pressure is kept between 50 and 80 grams. The idler wheel rapidly wears if the pressure is excessive. Slippage occurs if the pressure is smaller than the specification.

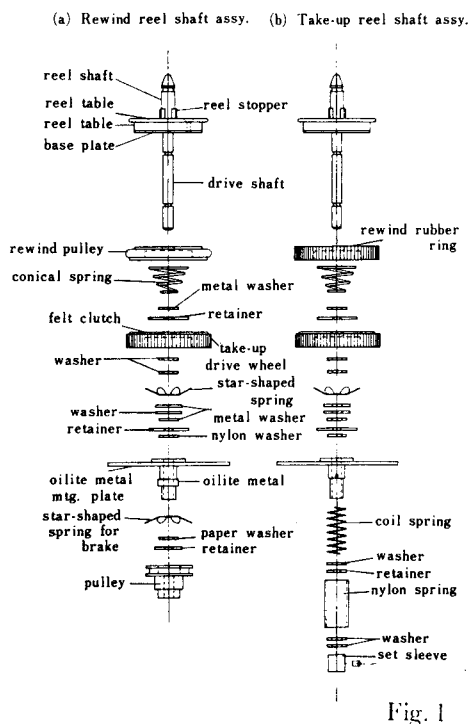

Fig. 1

3. ADJUSTMENT OF REWIND IDLER WHEEL

The rewind idler wheel must be kept in complete alignment with the rewind reel shaft. The amount of pressure to the knurled motor bushing should be maintained about 50 grams during rewind operation. Adjust both the idler load spring and rewind roller.

4. ADJUSTMENT OF INTERMEDIATE WHEEL

The intermediate wheel is located between the rewind idler wheel and the rubber ring which is used on the upper part of the supply reel shaft assembly. When the unit is set in rewind condition, it will contact with these parts simultaneously transmitting torque of motor. An adequate pressure is 50 grams. Adjust the load spring of the intermediate wheel if the pressure is not sufficient.

5. ADJUSTMENT OF TAKE-UP REEL SHAFT ASSEMBLY

A felt clutch material is attached to the bottom side of the reel table base plate so that recording tape will not be stretched during fast forwarding operation due to excessive tension. To check the amount of friction of this part, place a 5-inch reel with recording tape wound by 60 m/m in diameter, and gently pull the end of tape upward using a spring scale. Adjust the conical spring so that the amount of tension at this part will be kept between 400 to 500 grams. Another felt clutch material is attached to the take-up drive wheel. It is to provide proper slipping operation during record or play mode. The procedure for checking friction of this part is same as the foregoing, and between 150 and 200 grams of friction will provide the best result. Adjust the star-shaped spring just under the take-up drive wheel. When the unit is set to rewind operation, the amount of friction of this part will be greatly reduced and will become 15 to 20 grams. Check to see whether this is satisfactory, if not, readjust the star-shaped spring for Brake, and spring retainer washer accordingly. (See figure 1 (b) at left)

6. ADJUSTMENT OF SUPPLY REEL SHAFT ASSEMBLY

Felt clutch material is used between the lower side of the reel table base plate and the rewind rubber ring to protect recording tape from excessive tension during the recording operation. To check the amount of friction of this part, place onto the supply reel table a 5-inch reel with a tape 60 m/m in diameter, and gently pull the end of tape upward by a spring scale. Adjust the conical spring so that the amount of tension is kept between 400 and 500 grams. Other felt clutch material is attached to the rewind drive wheel to provide proper slipping operation during record or play operation. The procedure for checking friction of this part is the same as the foregoing, and between 80 and 120 grams of friction will give the best result. When the unit is set to fast forward operation, the amount of friction will be greatly reduced and will become 15 - 20 grams. Check to see whether this is correct. If not, readjust coil spring and spring retainer washer. (See figure 1 (a) at left)

7. ADJUSTMENT OF HEADS

(A) Adjustment of Head Height (See Fig-2 and Fig-3)

a. Erase Head

Adjust the height of the Erase Head by turning the height control screws (a) (a') as the upper edge of the tape passes through until it is just 0.125 – 0.15 mm under the top edge of the CH-1 erase head's core.

b. Playback Head

Adjust the height of the Playback Head by turning the height control screws (b) (b') as the upper edge of the tape passes through in the same way as the top edge of the CH-1 playback head's core.

(B) Adjustment of Vertical Azimuth of the Head

Adjust the vertical azimuth of each head (erase and playback) by turning the height control screws (a) to (b') until the tape contacts each head properly.

(C) Adjustment of Head Alignment

Playback Head

Playback an Ampex Alignment tape (8000 Hz) at 7-1/2" tape speed and turn the alignment control screw (c) until the out-put level of both channels reaches the maximum.

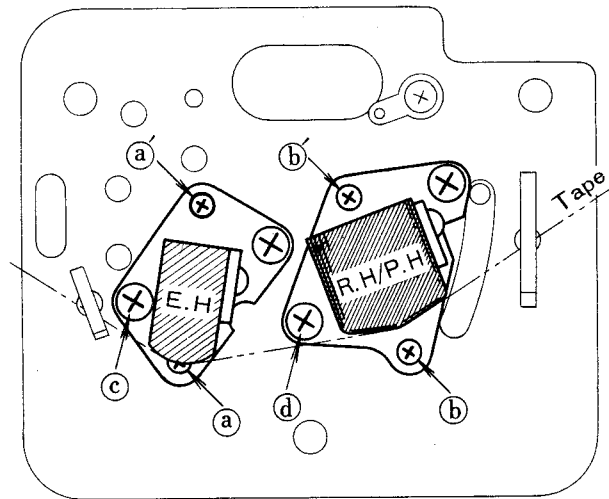

Fig. 2

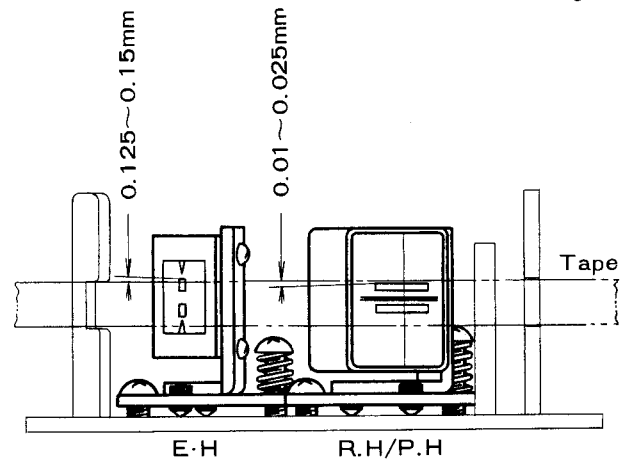

Fig. 3

VII. AMPLIFIER ADJUSTMENT

1. ADJUSTMENT OF RECORDING BIAS FREQUENCY (Fig. 1)

- Put on the resistor 10 or 50 ohms in series with the Bias Head and connect the Vertical Input Terminal of the Oscilloscope to points (a) and (b).
- Feed in the sine wave signal from an Audio Frequency Oscillator to the Horizontal Input of the Oscilloscope and tune the Dial of the Audio Frequency Oscillator until the Oscilloscope displays a circular or linear pattern.
- If it reads 60 K Hz \pm 5 K Hz, the Recording Bias Frequency is correct.
- If it is not correct, it may be adjusted by inserting another condenser (C-11) value 560 PF.

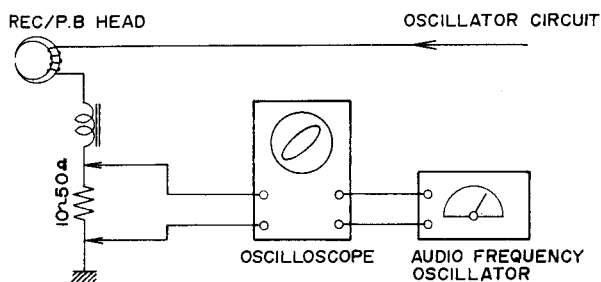

Fig. 1

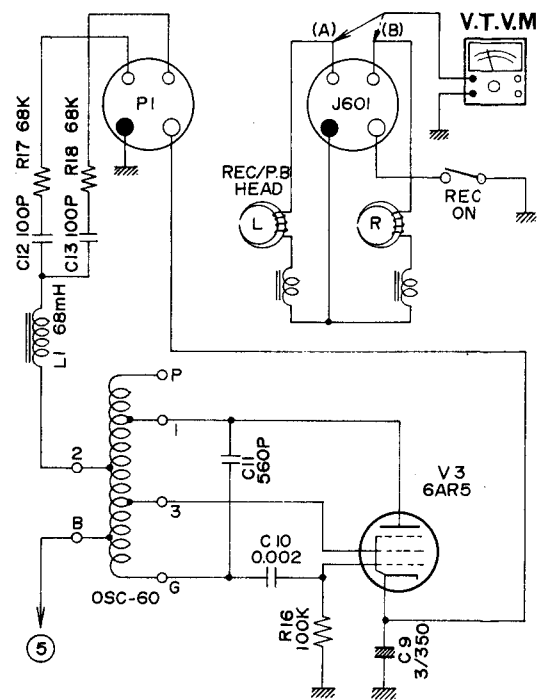

Fig. 2

2. ADJUSTMENT OF RECORDING BIAS VOLTAGE (Fig. 2)

- Connect the V.T.V.M. to the point (A) and (B), then read the figure on the meter of the V.T.V.M.
- If it reads AC 35 V \pm 5 V, the Recording Bias Voltage is correct.
- If it not correct, it may be adjusted by inserting another resistor (R-17, 18) value 68 K Ohms.

3. ADJUSTMENT OF ERASING BIAS VOLTAGE (Fig. 3)

- Connect the V.T.V.M. to the point (A) and (B), then read the figure on the meter of the V.T.V.M.
- If it reads AC 47 V \pm 10 V, the Erasing Bias Voltage is correct.
- If it not correct, it may be adjusted by inserting another regulator coil (L2, L3) value 22 mH.

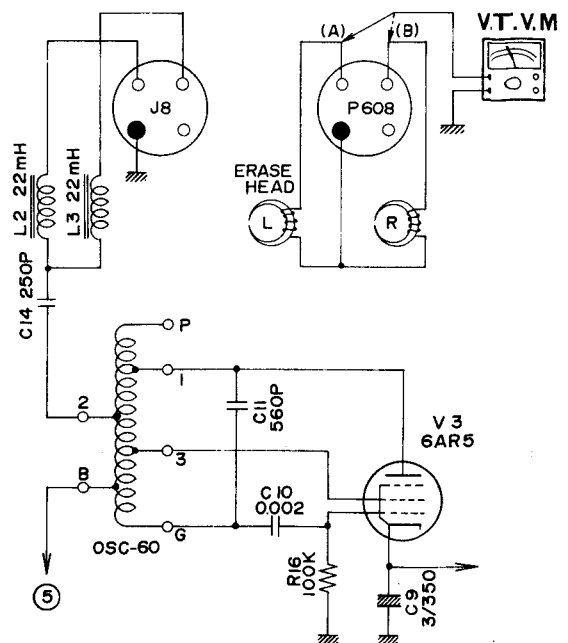

Fig. 3

VIII. MAINTENANCE PROCEDURES

1. LUBRICATION INSTRUCTION

For maximum service life and optimum performance, lubricate the parts identified below after each 500 hours of operation. Use only light machine oil of good quality.

Motor

Flywheel Assembly

Rewind Idler Wheel and Wind Take-Up Idler 1 drop

Intermediate Idler 1 drop

Pinch Wheel 1 drop

Also apply a liberal film of light machine grease to each roller surface of all levers and cams.

CAUTION: DO NOT OVER-LUBRICATE, AND WIPE OFF EXCESS OIL WITH A COTTON SWAB SOAKED IN ALCOHOL. OTHERWISE, EXCESS LUBRICANT MAY BE SCATTERED DURING OPERATION. AND THE RUBBER COMPONENT PARTS WILL DETERIORATE.

2. CLEANING TAPE HEADS AND OTHER PARTS

Wipe surface of tape heads, guide roller bearing, capstan bushing and pinch wheel periodically with a soft cloth soaked in alcohol or carbon-tet.

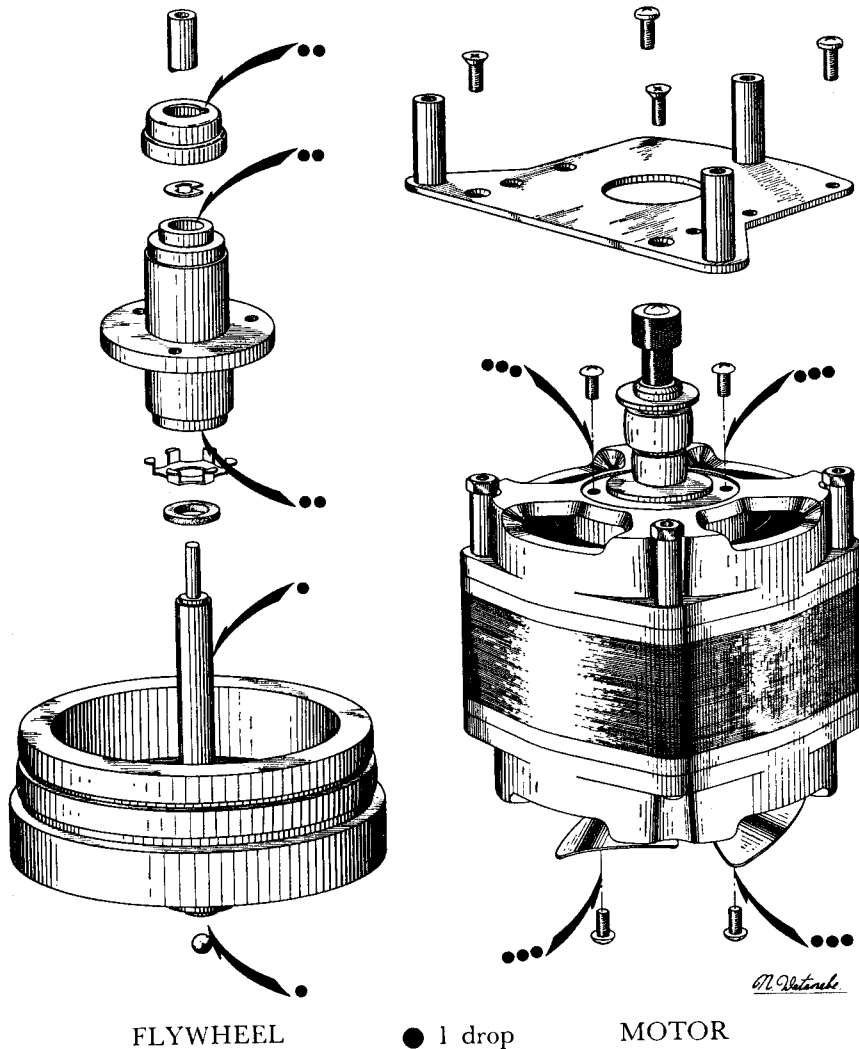

MEMO

IX. REPLACEMENT PARTS TABLE

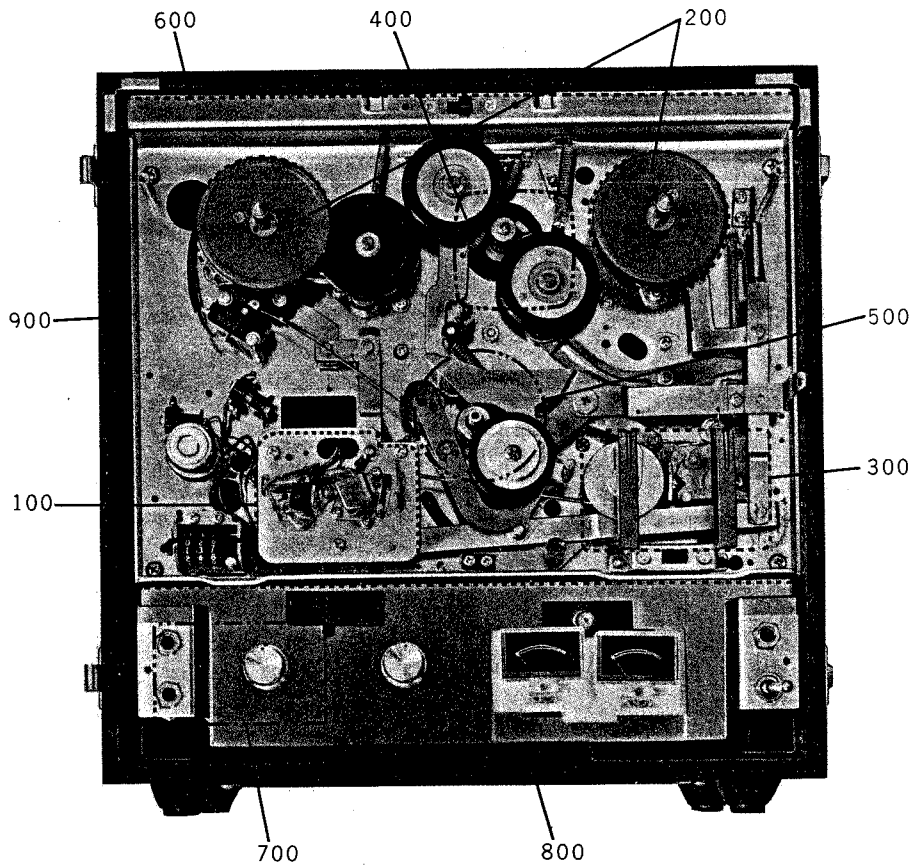

100	HEAD BLOCK
200	REEL ASSEMBLY BLOCK
300	SWITCH BLOCK
400	MOTOR BLOCK
500	FLY WHEEL BLOCK
600	MECHA. FRAME (front & rear)
700	PRE-AMPLIFIER CARD (1 & 2)
800	AMPLIFIER (1, 2 and 3)
900	CASE & TOP PANEL BLOCK

HEAD BLOCK

- LCS-101 Head Assembly,
Complete
- k Erase Head
l Record/Playback Head
r Table, Lifter Pin
(with Lifter Pin)
- LCS-102 Screw Flat Mould 4x8
LCS-103 Prop C, Head
LCS-623 Cam A, Head Lifter
b Spoke, for Lifter

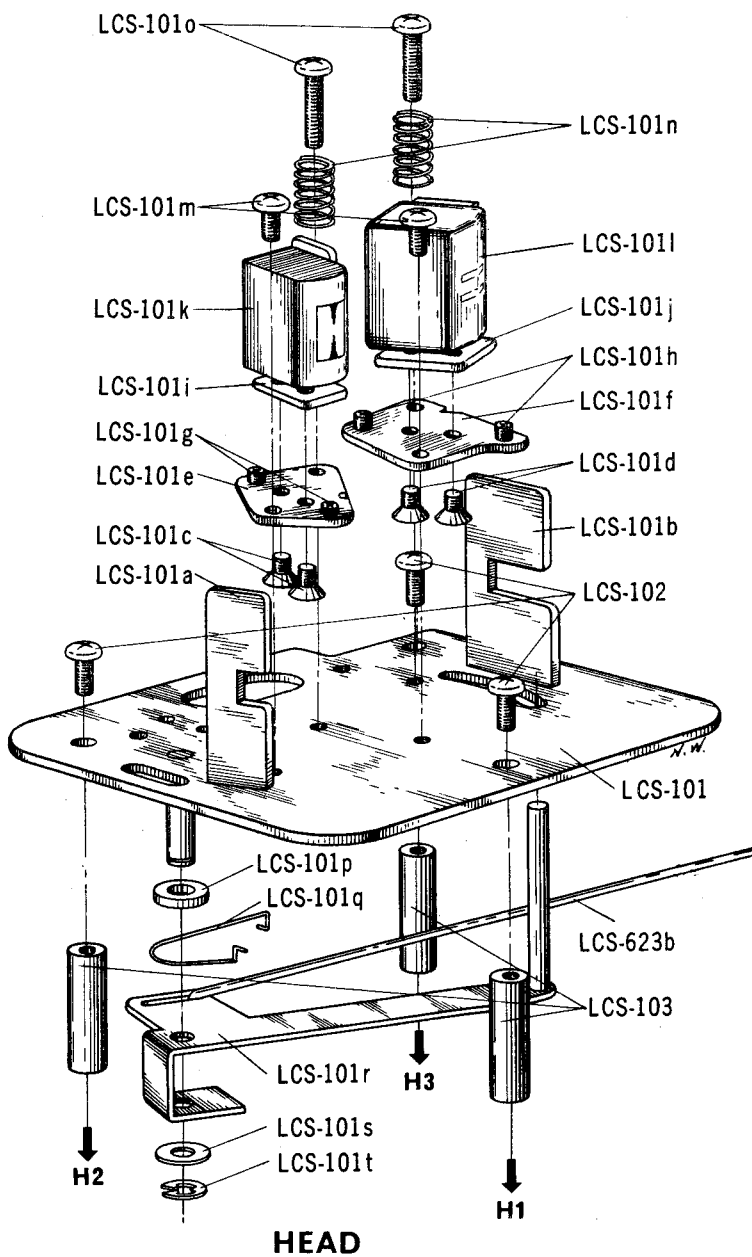

REEL ASSEMBLY BLOCK

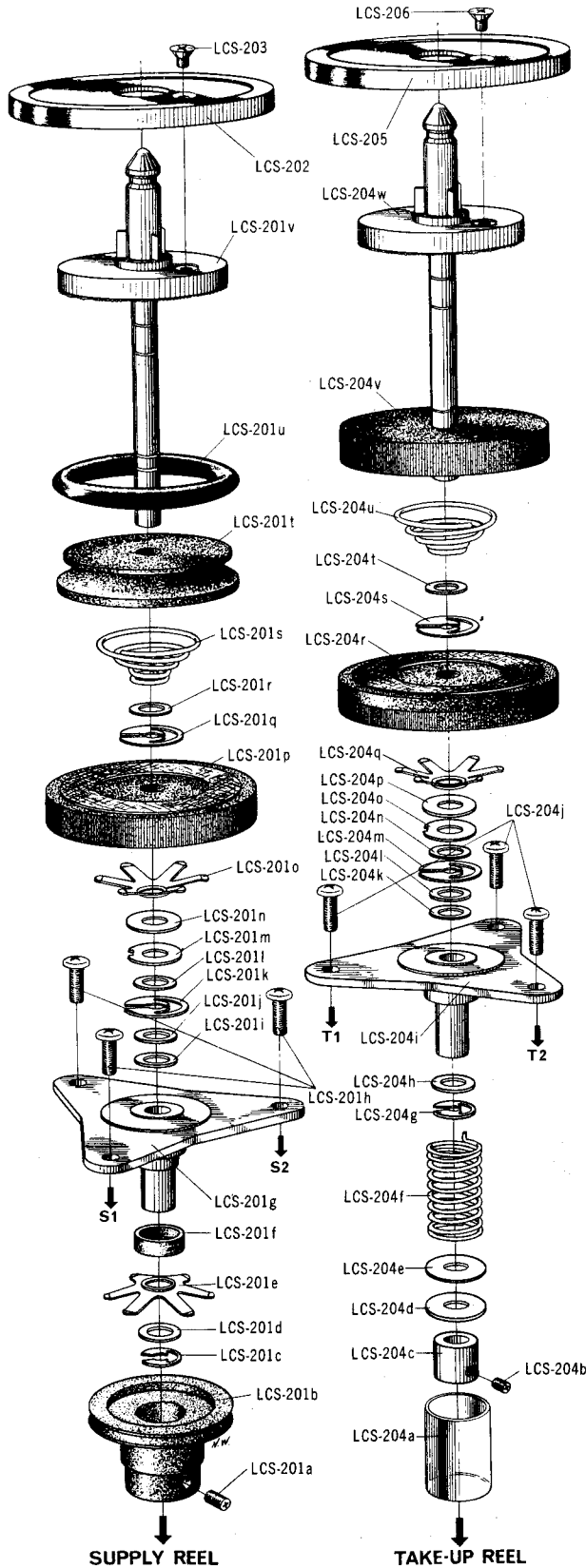

- LCS-201 Supply Reel Assembly
- a Screw, without Head 4x7
 - b Pulley, Reel Shaft
 - e Holder, Reel Shaft (Star Type Spring)
 - g Metal Fitting A, Reel Table
 - o Holder, Reel Shaft (Star Type Spring)
 - p Take-up Roller, C
 - s Spring G, Left
 - t Rewind Pulley
 - u Rubber Ring
 - v Table C, Reel
- LCS-202 Plate, Reel Table
- LCS-203 Screw Flat 3x6
- LCS-204 Take-up Reel Assembly
- a Nylon Tube
 - b Screw, without Head 3x3
 - c Set Sleeve
 - f Spring, F3
 - i Metal Fitting B, Reel Table
 - q Holder, Reel Shaft (Star Type Spring)
 - r Take-up Roller, B
 - u Spring G, Right
 - v Take-up Roller, A
 - w Reel Shaft A, Take-up Reel
- LCS-205 Plate, Reel Table
- LCS-206 Screw Flat 3x6

SWITCH BLOCK

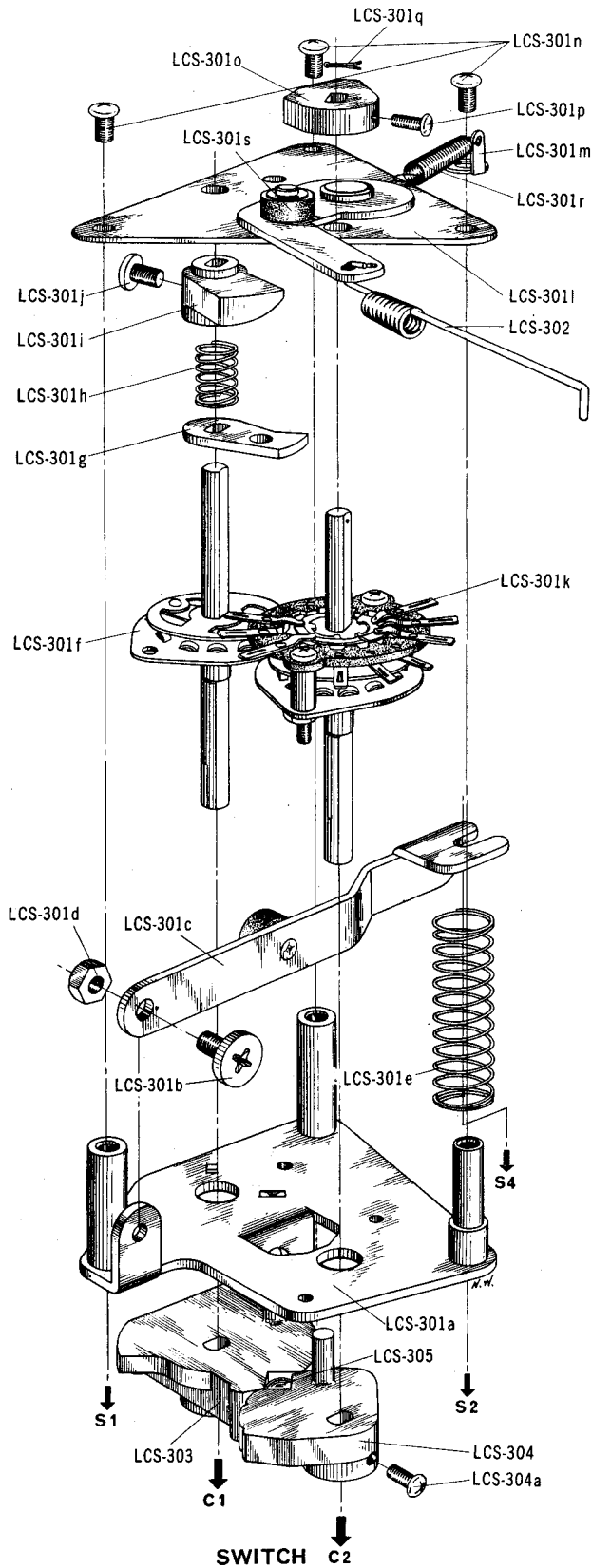

- LCS-301 Switch Block
- a Switch Table, A
- c Lever, I
- d Nut
- f Fast/Forward
 Rewind Shaft
- g Plate, Cam
- h Spring, K
- i Cam, C
- k Rotary Switch
 S-133-B
- l Switch Table, B-2
- q Pin
- t Washer
- u Screw Bind 3x5
- LCS-302 Record/Playback
 Conversion Pin
- LCS-303 Cam A-2
- LCS-304 Cam B
- LCS-305 8 mm Ball Bearing

MOTOR BLOCK

- LCS-401 Motor, Complete
- a Screw Flat Mould
3x15
 - b Stepped Pulley
 - c Belt Holder
 - d Motor Pulley
 - g Motor Holder
 - h Hexagonal Nut
 - j Motor Fan, D
 - k Screw, without Head
4x5
 - n Prop A, Motor
(8x22.5)
 - o Prop B, Motor
(8x21.5)
 - q Holder,
Motor Condenser
 - r MP Condenser 2 μ f
(260V AC)
 - s Wire Wound Fixed
Power Resistor
(450 Ω 20H)

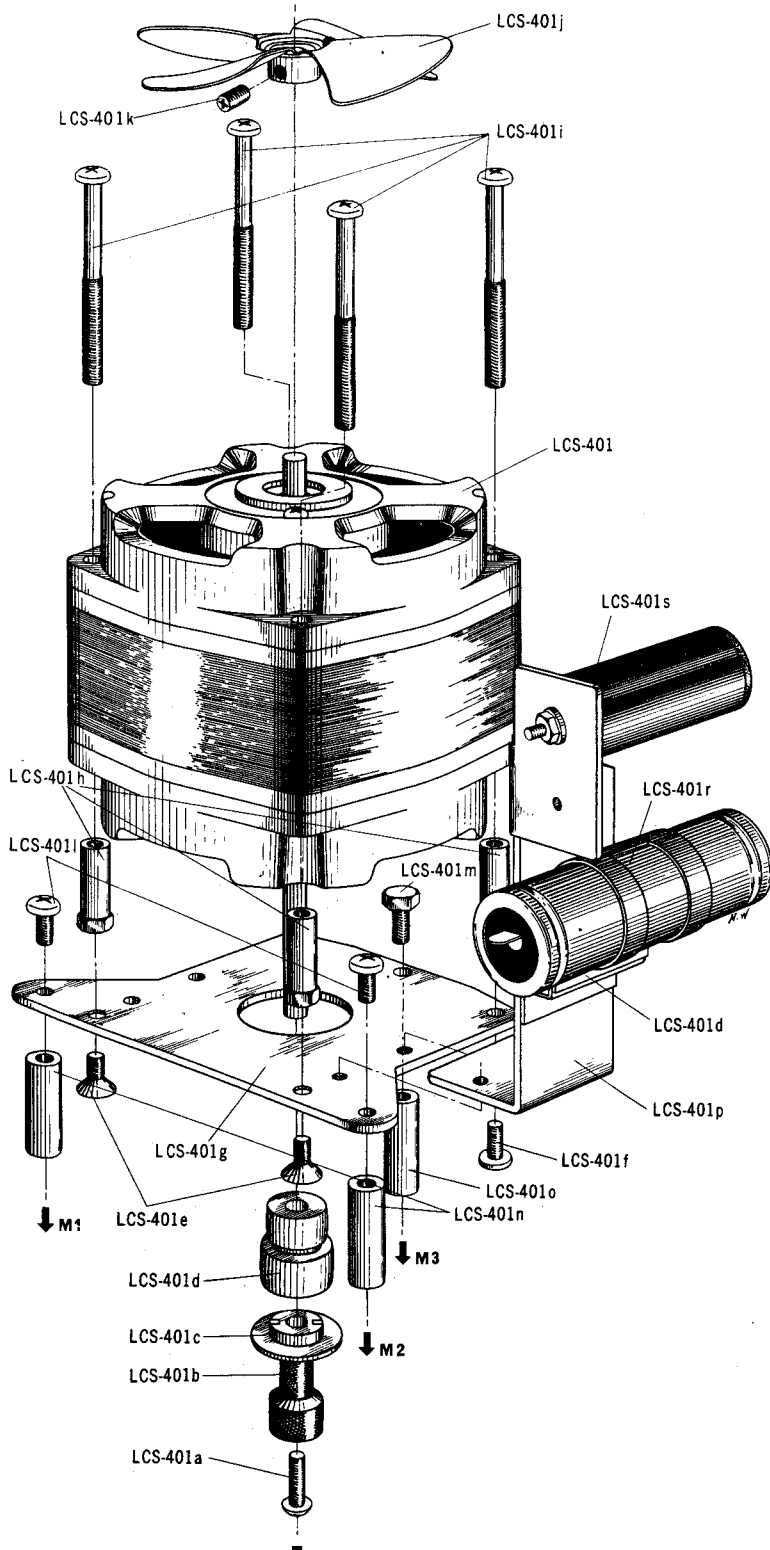

MECHA. BLOCK (FRONT)

LCS-601	Deck Frame	a	Lever, Supply Brake
LCS-602	Prop, Panel	b	Supply Brake Roller
LCS-603	Prop, Tape Guide	c	Screw, Brake Roller
	a Table B, Tape Guide	d	3 mm Nut
	b Washer	e	Washer Pin
	c Table, Washer	f	Spring, UN-D
	d Bearing (635JZZ)	LCS-618	Shaft, Take-up Brake Lever
	e Table, Washer	a	Lever, Take-up Brake
	f Washer	b	Take-up Brake Roller
	g Table A, Tape Guide	c	Screw, Brake Roller
LCS-604	Index Counter, Complete	d	3 mm Nut
	a Pulley, Counter	e	Washer Pin
LCS-605	Plate, AS Lever with Prop	f	Spring, D
	a 3 mm Ground Lug	LCS-619	Lever, A (with Lever E)
	b Screw Bind 3x5	a	Washer Pin
	c Spring, AS Lever	b	Washer
	d AS Lever, Complete	c	Washer Pin
	e Washer Pin	LCS-620	Lever, C3
LCS-606	Recording Safety Button	a	Washer
	a Cam Stopper	b	Washer Pin
	b Insulator Plate, Cam Stopper	c	Spring D
	c Fiber, Cam Stopper	LCS-621	Lever, Pinch Wheel
	d Screw Flat Mould 4x8	a	Shaft A, Cam Roller
LCS-607	6P Slide Switch ESS-22C-NB	b	Cam Roller B
	b Plate, Automatic Switch	c	Shaft C, Pinch Wheel
	c Screw Semi-Cubic 3x5	d	4 mm Nut
LCS-608	6P Slide Switch ESS-22C-NC	e	Spring, A
LCS-609	Shaft, Lever A	LCS-622	Instant Stop/Pause Lever, A
LCS-610	Lever B, with Lever E	a	Stopper, Instant Stop Lever
	a Cam Roller, A	b	Screw Bind 3x5
	b Cam Roller, B	c	Screw, Retaining Instant Stop Lever
	c Washer Pin	d	Spring, Instant Stop Lever
	d Spring, B	e	Holder B, Instant Stop Lever
LCS-611	Holder B, Spring	f	Screw Flat Mould 4x8
LCS-612	Holder, Lever G Metal Lever, G with Lever H-D	LCS-623	Cam A, Head Lifter
	b Idler Shaft, B	a	Cam B, Head Lifter
	c Spring, Idler	b	Spoke, for Lifter
	d Stopper, Lever G	LCS-624	Lever K
LCS-613	Shaft, Pinch Wheel Lever	a	Screw A
	a Lever, FA	b	Torsion Spring, D
	b Cam Roller, A	LCS-625	Idler Wheel
	c Washer Pin	a	Washer
LCS-614	Pin B, Spring	b	Washer Pin
LCS-615	Table, Lever FB	LCS-626	Internal Wheel
	a Spring, Lever FB	a	Washer
	b Screw Flat Mould 4x10 *	b	Washer Pin
LCS-616	Lever F, (for Motor)	LCS-627	Prop, Micro Switch
	b Washer Pin	a	Micro Switch M8-3
	c Fiber Washer	b	Screw Flat Mould 3x15
LCS-617	Shaft, Supply Brake Lever	c	Washer
		LCS-628	Hum Bucking Coil (40T)
		a	Holder, Hum Bucking Coil

- b Screw Semi-Cubic
- c 3 mm Nut 3x22
- LCS-629 4P Jack
- a 3P Lug Plate
- LCS-630 Metal Fitting, Belt Change Lever
- c Spring B, Belt Change Lever
- LCS-303 Cam A-2
- LCS-304 Cam B
- LCS-305 8 mm Ball Bearing

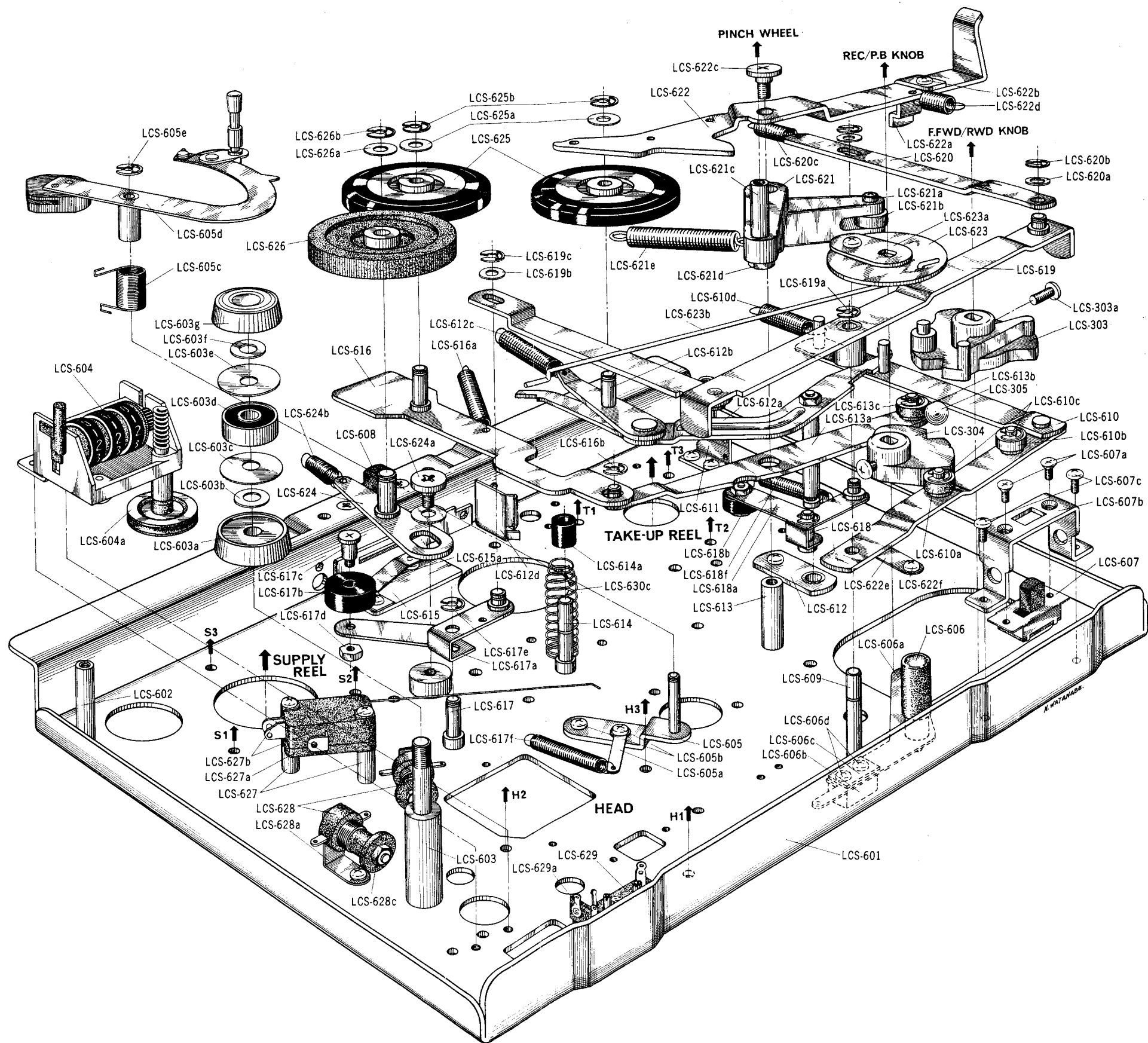

MECHA. BLOCK (REAR)

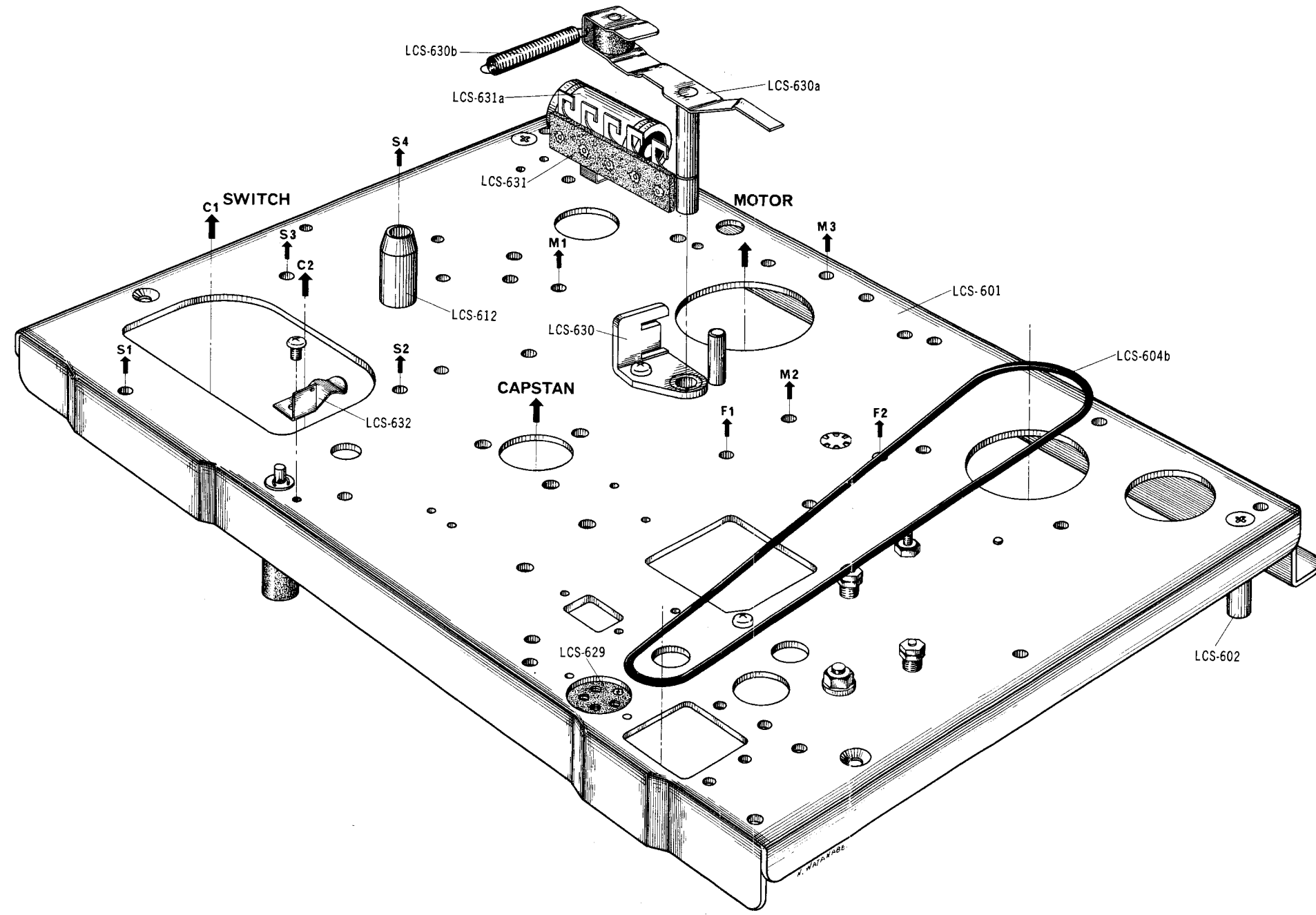

- LCS-601 Deck Frame
- LCS-602 Prop, Panel
- LCS-604 Index Counter, Complete
- b Belt, Counter
- LCS-612 Holder, Lever G Metal
- LCS-629 4P Jack
- LCS-630 Metal Fitting, Belt Change Lever
- a Lever, Belt Change
- b Spring, Belt Change Lever
- LCS-631 3L1 Lug Plate
- a MP Condenser 1μ 220V AC
- LCS-632 Cord Holder

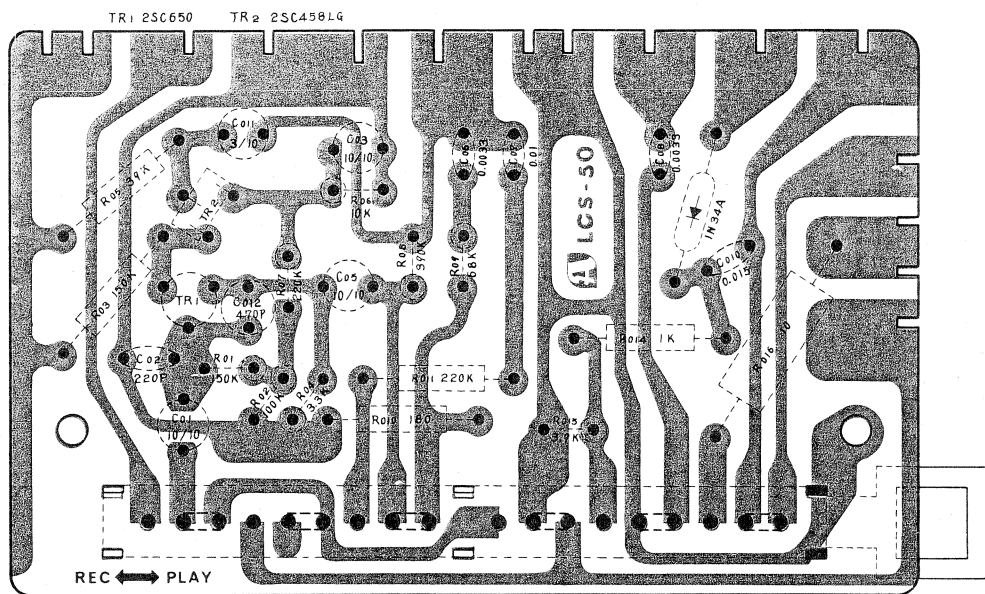
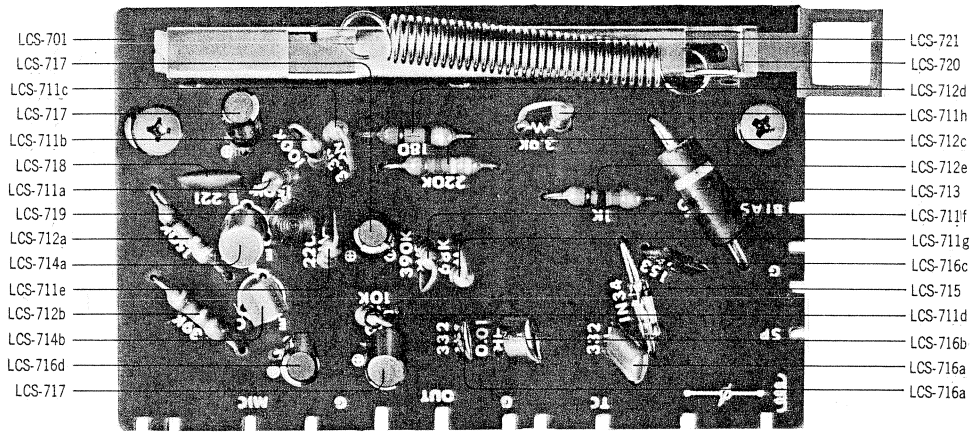

PRE-AMPLIFIER CARD BLOCK

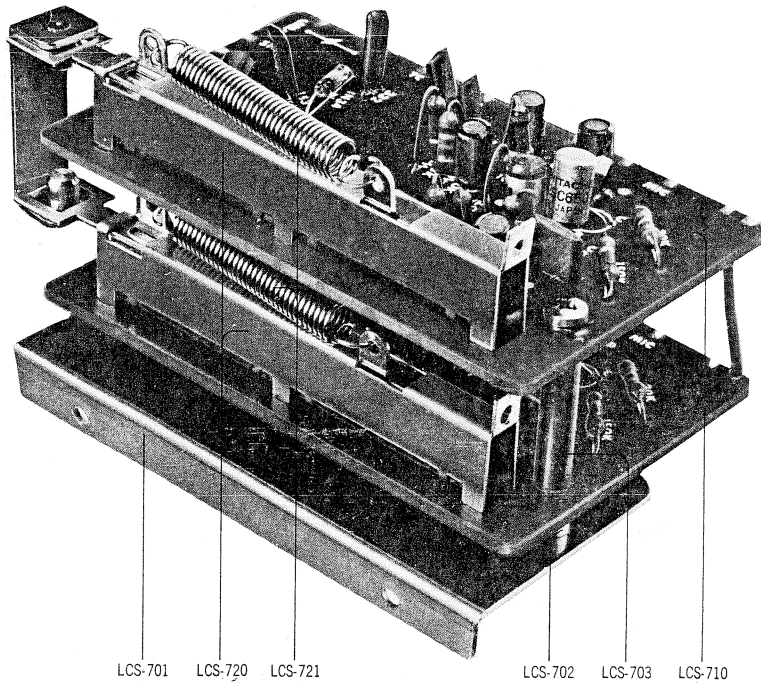

- LCS-701 Holder Pre-amplifier
Card
- LCS-702 Prop B, Pre-amplifier
- LCS-703 Prop, Printed Card
- LCS-710 Pre-amplifier Card
Complete
- LCS-711 Carbon Resistor
with Stopper
 - a 150K 1/4 W (R01)
 - b 100K 1/4 W (R02)
 - c 3.3K 1/4 W (R04)
 - d 10K 1/4 W (R06)
 - e 220K 1/4 W (R07)
 - f 390K 1/4 W (R08)
 - g 68K 1/4 W (R09)
 - h 3.9K 1/4 W (R015)
- LCS-712 Carbon Resistor
 - a 150K 1/4 W (R03)
 - b 39K 1/4 W (R05)
 - c 220K 1/4 W (R011)
 - d 180Ω 1/4 W (R010)
 - e 1K 1/4 W (R014)
- LCS-713 Fixed Composition
Resistor 10 Ω 1W (R016)
- LCS-714 Transistor
 - a 2SC-650 (C)
 - b 2SC-459LG (C,D)
- LCS-715 Germanium Diode
IN34A
- LCS-716 Vertical Mounting Type
Mylar Condenser
 - a 0.003μ 50V (C06, C08)
 - b 0.01μ 50V (C07)
 - c 0.015μ 50V (C010)
 - d 3μ 10V (C011)
- LCS-717 Vertical Mounting Type
Electrolytic Condenser
10μ 10V(C01, C03, C05)
- LCS-718 Polyethylene Condenser
220P (C02)
- LCS-719 VFM Condenser
470P (K) 50WV (C012)
- LCS-720 Slide Switch (Record/
Playback)
- LCS-721 Amplifier Spring

AMPLIFIER BLOCK I

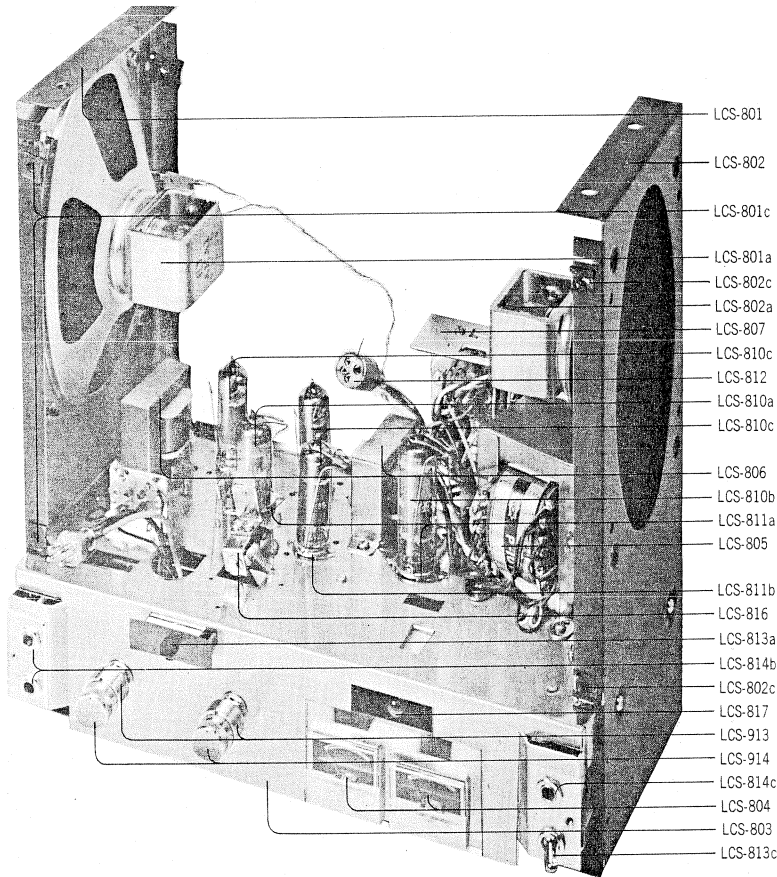

- LCS-801 Chassis A, Speaker
 - a Speaker 5x7"
 - b Screw Flat Mould 4x12
 - c Speed Nut
- LCS-802 Chassis B, Speaker
 - a Speaker 5 x 7"
 - b Screw Flat Mould 4x12
 - c Speed Nut
- LCS-803 Amplifier Chassis
- LCS-804 VU Meter
- LCS-805 Power Transformer
- LCS-806 Out-Put Transformer
- LCS-807 AC Changing Complete
 - a Angle, Changing Voltage
 - b 6P Slide Switch
 - c Name Plate, Cycle Change
 - d Socket, Change Voltage
 - e Plug, Change Voltage
 - f Hexagonal Prop, Selector
 - g Name Plate, AC Change
 - h M 3 Cap Nut
- LCS-808 Fuse Extractor Post
 - a Fuse (1.5A)
- LCS-809 Power Supply Cord
 - a Rubber Bush, Power Cord
- LCS-810 Vacuum Tube
 - a 12AT7
 - b 6CA4
 - c 6AR5
- LCS-811 Vacuum Tube Socket
 - a 9P Mould Type
 - b 7P Mould Type
- LCS-812 4P Socket
- LCS-813 Switch
 - a Track Selector (8P Slide)
 - b Speaker ON/OFF (6P Slide)
 - c Power ON/OFF (Toggle)
 - d Cycle Change (6P Slide)

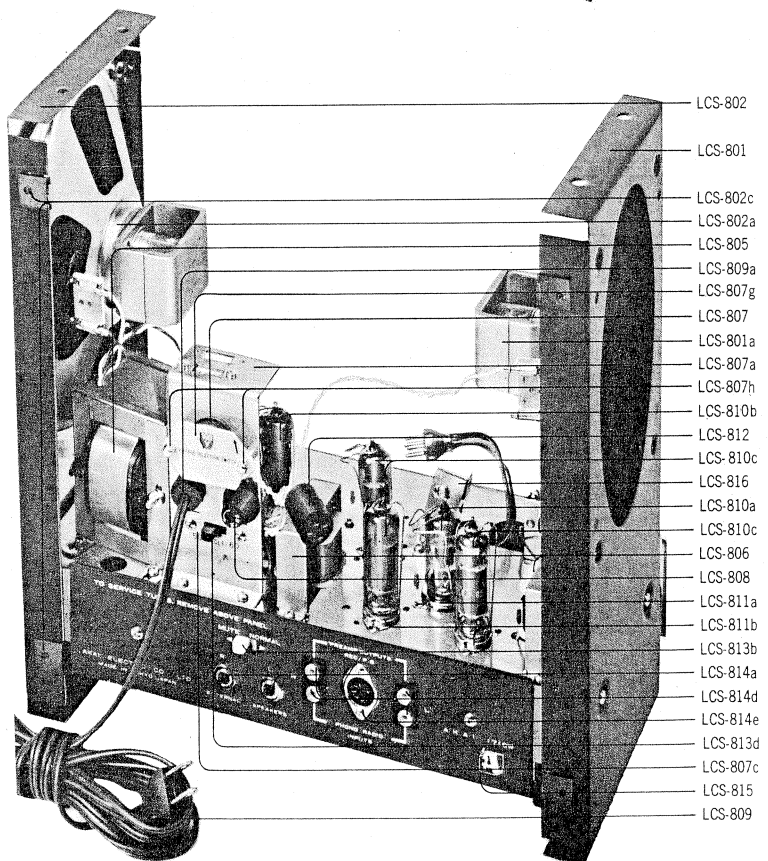

- LCS-814 Jack
 - a External Speaker (2 Conductor E Jack)
 - b MIC. (2 Conductor E Jack)
 - c Headphone (3 Conductor E Jack)
 - d Pin (2 Connective)(2 used)
 - e DIN (5P Receptacle Socket)
- LCS-815 1710W Name Plate
- LCS-816 Recording Lever Block
 - a Lever, Recording I
 - b Lever, Recording II
 - c Lever, Recording III
 - d Binding, Washer Hd. 3x5
 - e Holder, Tension Shaft
 - f Spring UL Lock Lever
- LCS-817 Pilot Lamp
 - a Lamp Socket
- LCS-913 Amplifier Knob A(Tone)
- LCS-914 Amplifier Knob B(Volume)

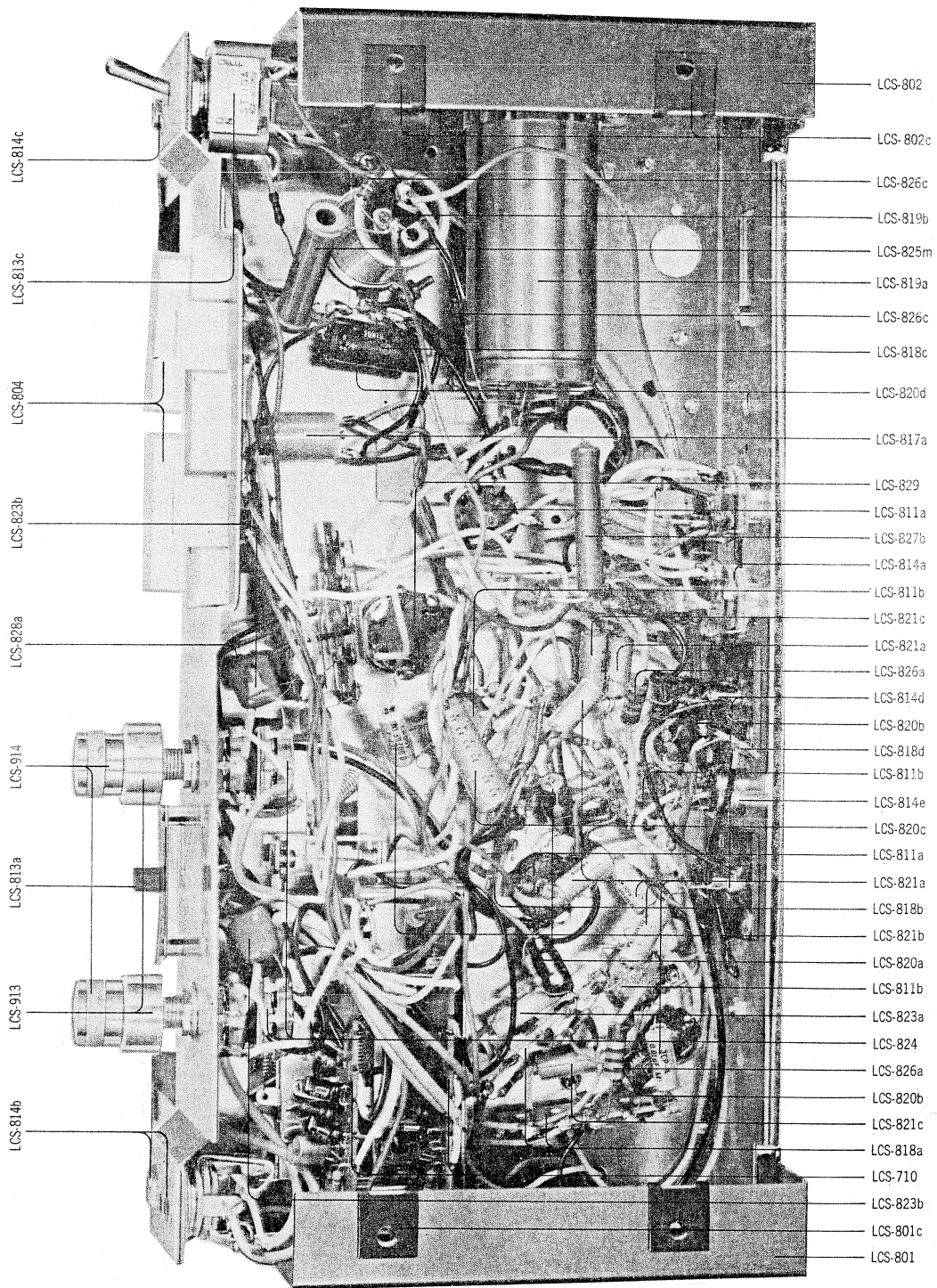

AMPLIFIER BLOCK II

LCS-801	Chassis A, Speaker	i	5.6K 1/4W (R12)
c	Speed Nut	j	3.9K 1/4W (R13)
LCS-802	Chassis B, Speaker	k	220Ω 1/4W (R14)
c	Speed Nut	l	68K 1/4W (R17, R18)
LCS-804	VU Meter	m	33K 2L (R20)
LCS-811	Vacuum Tube Socket	LCS-826	Fixed Composition Resistor
a	9P Mould Type	a	470Ω 1W (R9)
b	7P Mould Type	b	6.8K 1/4W (R19)
LCS-813	Switch	c	2.7K 1/2W (R21)
a	Track Selector (8P Slide)	d	680Ω 1/2W (R22)
c	Power ON/OFF (Toggle)	LCS-827	Wired Resistor
LCS-814	Jack	a	8Ω 1W (R15)
a	External Speaker (2 Conductor E Jack)	b	330Ω 6P (R23)
b	MIC. (2 Conductor E Jack)	LCS-828	Coil
c	Headphone (3 Conductor E Jack)	a	68 mH (L1)
d	Pin (2 Connective) (2 used)	b	22 mH (2 used) (L2, L3)
e	DIN (5P Receptacle Socket)	LCS-829	Oscillator Coil(60KC)
LCS-817	Pilot Lamp	LCS-710	Pre-amplifier Card Complete
a	Lamp Socket	LCS-913	Amplifier Knob A (Tone)
LCS-818	Lug Plate	LCS-914	Amplifier Knob B (Volume)
a	2L2		
b	2L3		
c	1L3		
d	1L1		
LCS-819	Lug Terminal Type Electrolytic Condenser		
a	100 + 100μ 350V		
b	20 + 20μ 350V		
LCS-820	Tublar Type Electrolytic Condenser		
a	100μ 3V (C1)		
b	50μ 25V (C4)		
c	3μ 350V (C9)		
d	20μ 50V (C15)		
LCS-821	Oil Tublar Type Condenser		
a	0.01μ 400V (C2, C3, C6)		
b	0.002μ 400V (C10)		
c	0.001μ 400V (C5)		
LCS-822	FM Condenser		
a	300J 500V (C7)		
b	561J 500V (C11)		
c	101J 500V (C12, C13)		
d	251J 500V (C14)		
LCS-823	Mylar Condenser		
a	FNX 0.33μ 100V (C8)		
b	MFL 0.1μ 50V (C20)		
LCS-824	Volume/Tone Control (500K/50K)		
LCS-825	Carbon Resistor		
a	100K 1/4W (R1, R6, R11, R16)		
b	33K 1/4W (R2)		
c	3.3K 1/4W (R3)		
d	560Ω 1/4W (R4)		
e	150Ω 1/4W (R5)		
f	390K 1/4W (R7)		
g	82K 1/4W (R8)		
h	1.2M 1/4W (R10)		

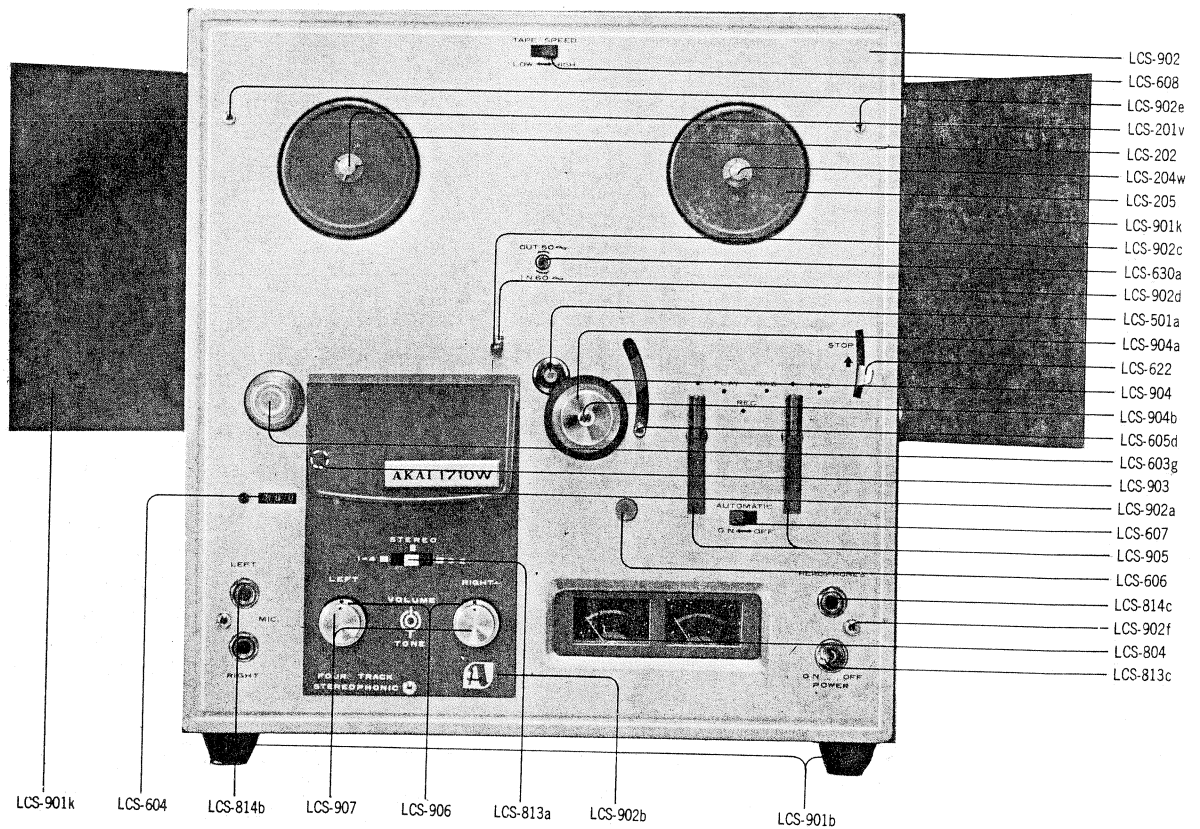
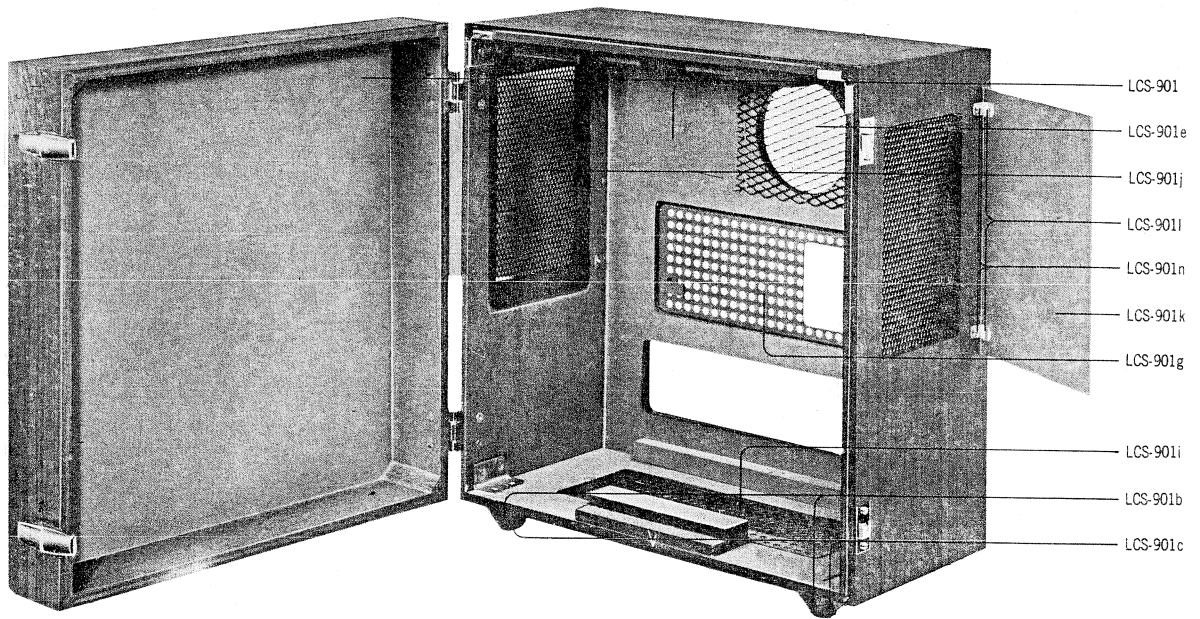

CASE & TOP PANEL BLOCK

LCS-901	Case Assembly, Complete	LCS-622	Instant Stop/Pause Lever, A
a	Case	LCS-630	Metal Fitting, Belt Change Lever
b	Table, Rubber Foot	a	Lever, Belt Change
c	Rubber Foot	LCS-804	VU Meter
d	Screw Semi-Cubic 3x18	LCS-813	Switch
e	Ventilator, A	a	Track Selector (8P Slide)
f	Screw Truss 3x12	c	Power ON/OFF (Toggle)
g	Ventilator, B	LCS-814	Jack
h	Screw Truss	b	MIC. (2 Conductor E Jack)
i	Panel Escucheon	c	Headphone (3 Conductor E Jack)
j	Russ Plate, Speaker		
k	Speaker Reflector		
l	Holder, Speaker Reflector		
n	Screw Truss 3x6		
LCS-902	Front Panel		
a	Head Cover with Name Plate		
b	Frame, Head Cover		
c	Capstan Rest		
d	Capstan Holder		
e	Screw Truss 3x6		
f	Screw Truss 4x8		
LCS-903	Tape Cleaner, Complete		
a	Base, Tape Cleaner		
b	Cap, Tape Cleaner		
c	Tape Cleaner Pad		
d	Holder, Tape Cleaner		
LCS-904	Pinch Wheel		
a	Metal Cap, Pinch Wheel		
b	Screw, Pinch Wheel		
LCS-905	Knob, Record/Playback & Rewind Fast Forward		
LCS-906	Amplifier Knob A (Tone)		
LCS-907	Amplifier Knob B (Volume)		
LCS-201	Supply Reel Assembly		
v	Table C, Reel		
LCS-202	Plate, Reel Table		
LCS-204	Take-up Reel Assembly		
w	Reel Shaft A, Take-up Reel		
LCS-205	Plate, Reel Table		
LCS-501	Flywheel, Complete		
a	Capstan		
LCS-603	Prop, Tape Guide		
g	Table A, Tape Guide		
LCS-604	Index Counter, Complete		
LCS-605	Plate, AS Lever with Prop		
d	AS Lever, Complete		
LCS-606	Recording Safety Button		
LCS-607	6P Slide Switch ESS-22C-NB		
LCS-608	6P Slide Switch ESS-22C-NC		

X. TROUBLE SHOOTING CHART

SECTION "A" TROUBLES WITH AMPLIFIER

A. Playback problems. (Unit set in play position.)

1. No sound from loud speaker.

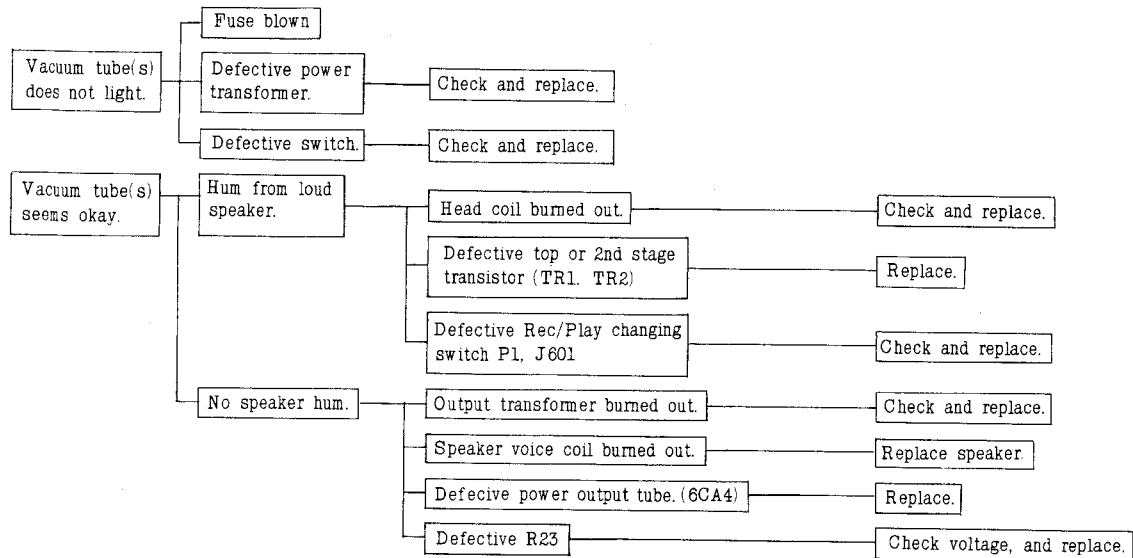

2. Sound from speaker but insufficient volume.

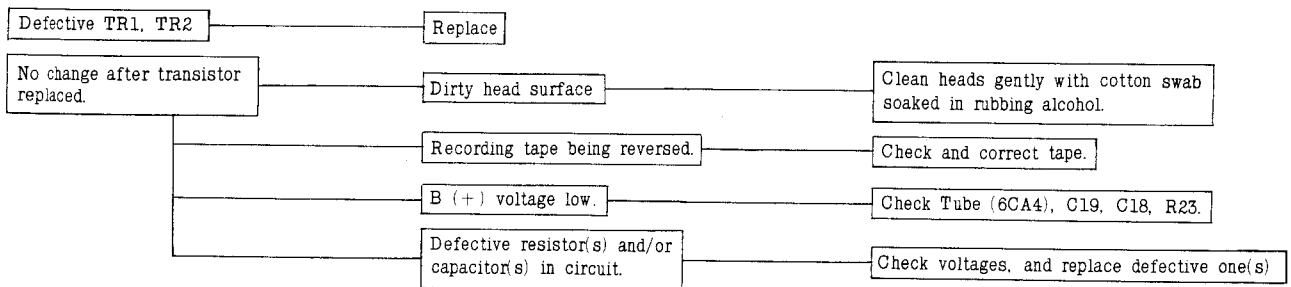

3. Sound from speaker but with loud hum.

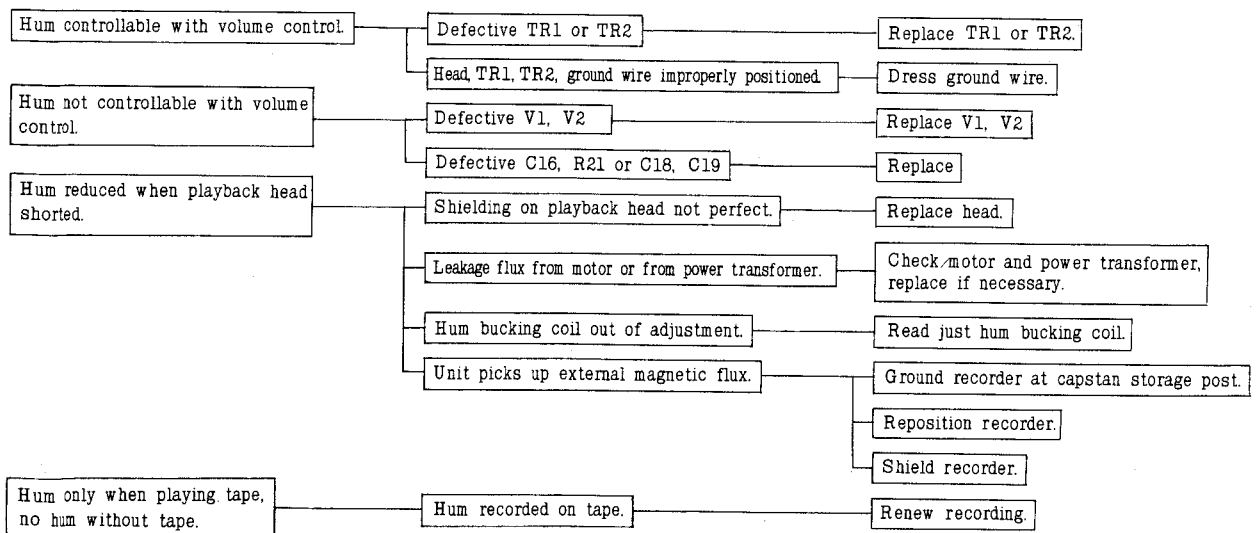

4. Intermittent noise.

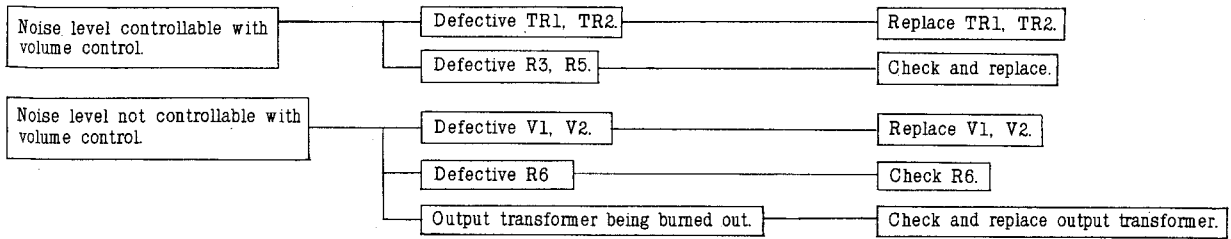

5. Constant background noise from speaker.

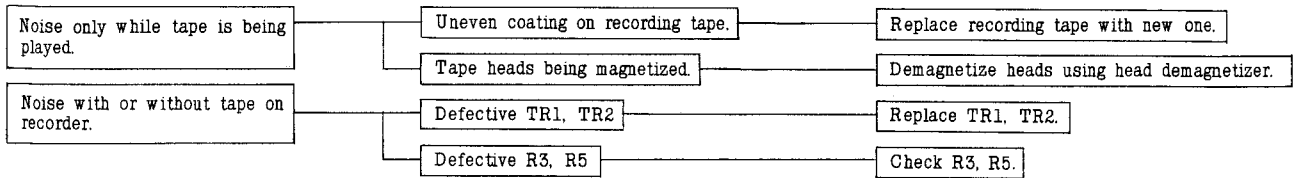

6. Lack of bass.

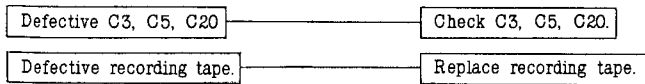

7. Lack of treble.

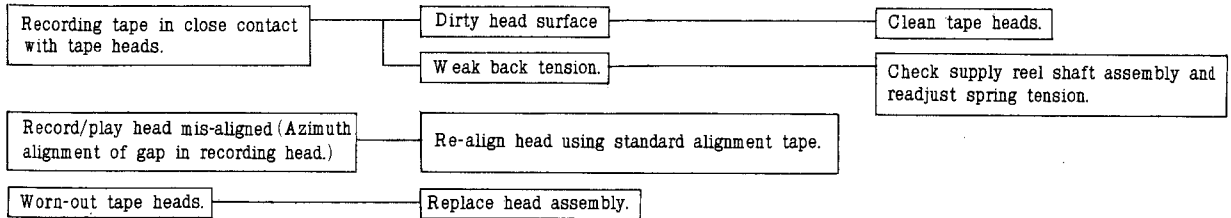

8. Sound distorted.

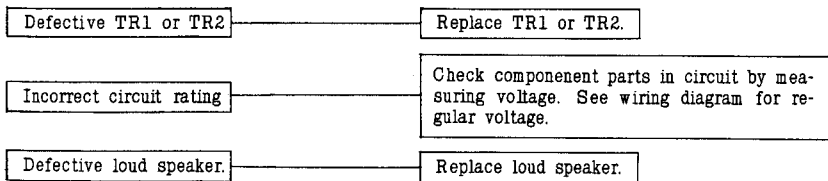

B. Recording problems.

(Unit plays back pre-recorded tapes okay, but recording not satisfactory.)

9. No recording possible.

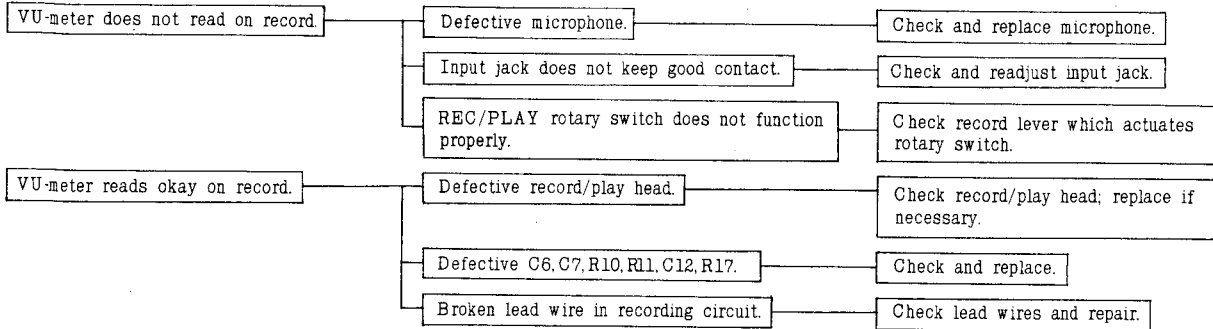

10. Sound distorted.

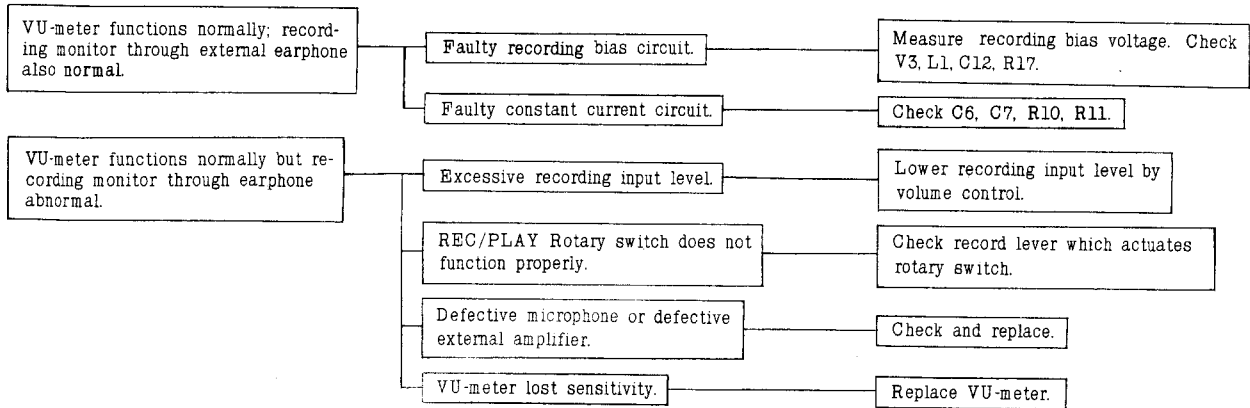

11. Erasing problems.

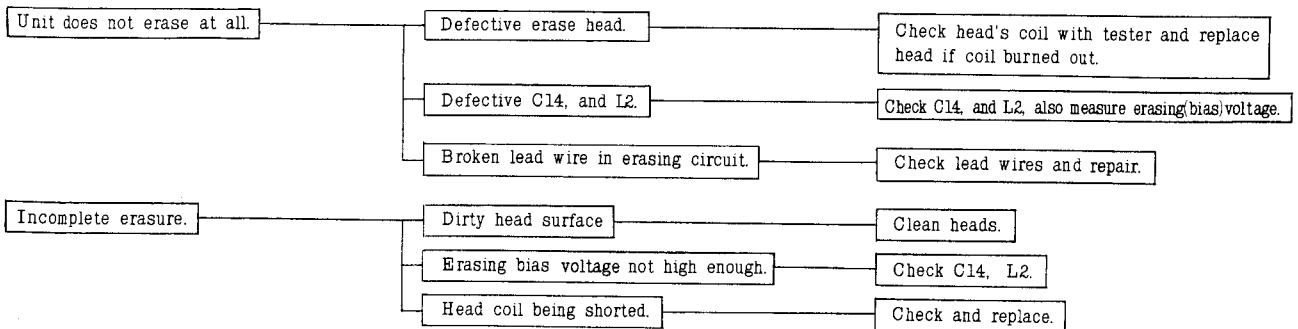

12. Insufficient treble on recording.

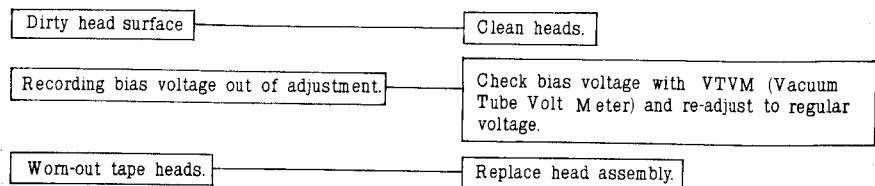

13. Noisy recording. (Constant and loud background noise recorded on tape.)

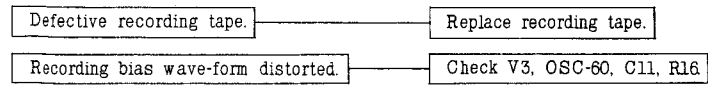

14. Low recording sensitivity.

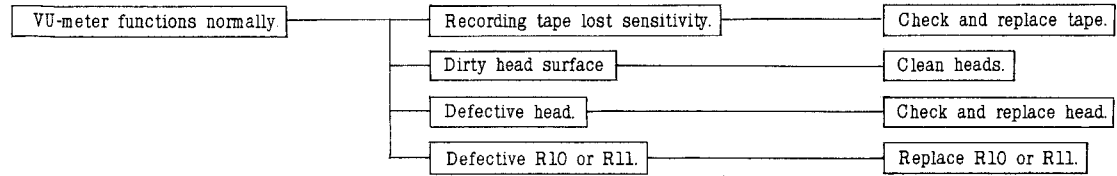

SECTION "B" TROUBLES WITH TAPE TRANSPORT MECHANISM.

1. Capstan does not rotate.

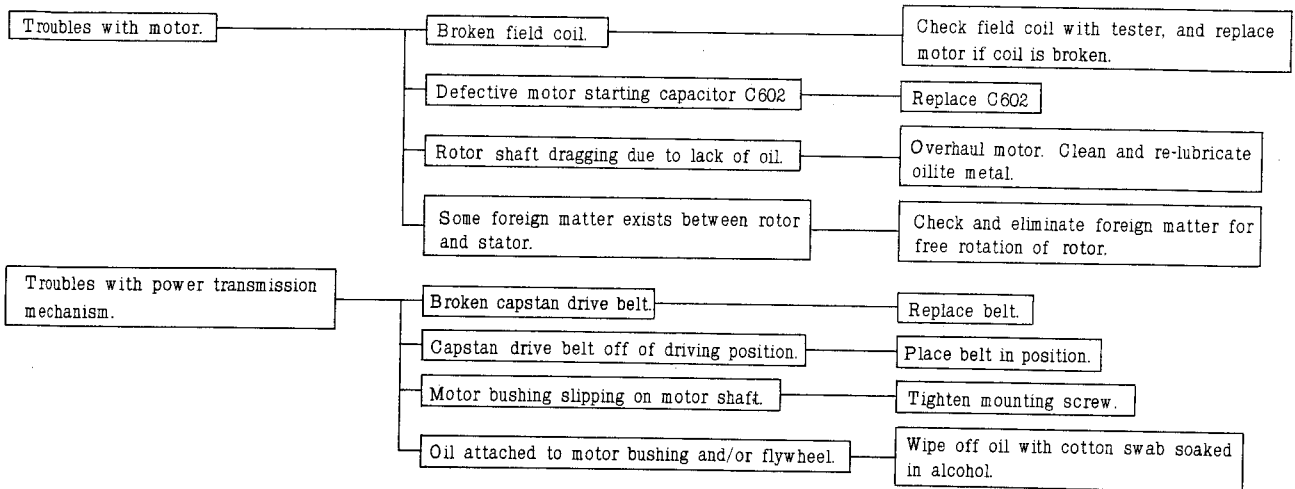

2. Capstan rotates in Stop position, but tape does not advance when switched to Play position.

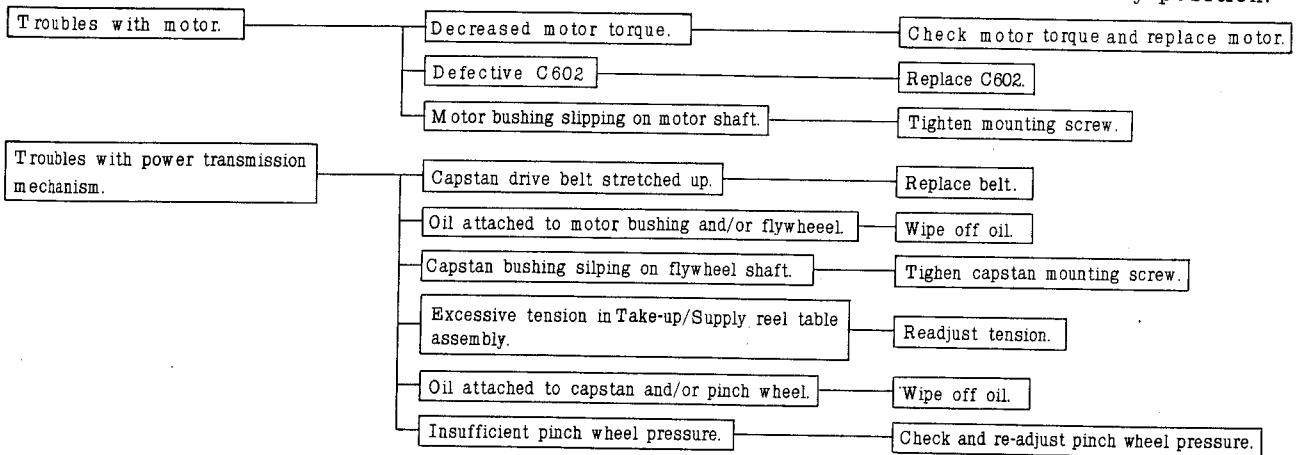

3. Capstan advances tape, but take-up reel does not take up tape.

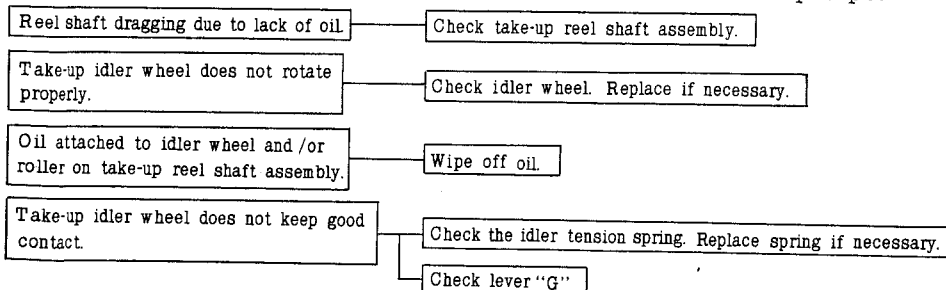

4. Take-up functions normally, but tape speed lower than regular speed.

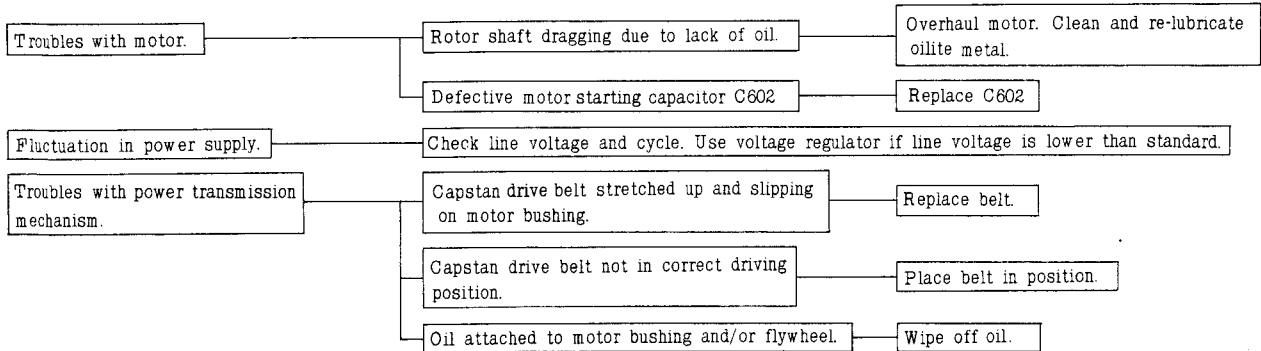

5. Wow flutter. Irregular tape movement.

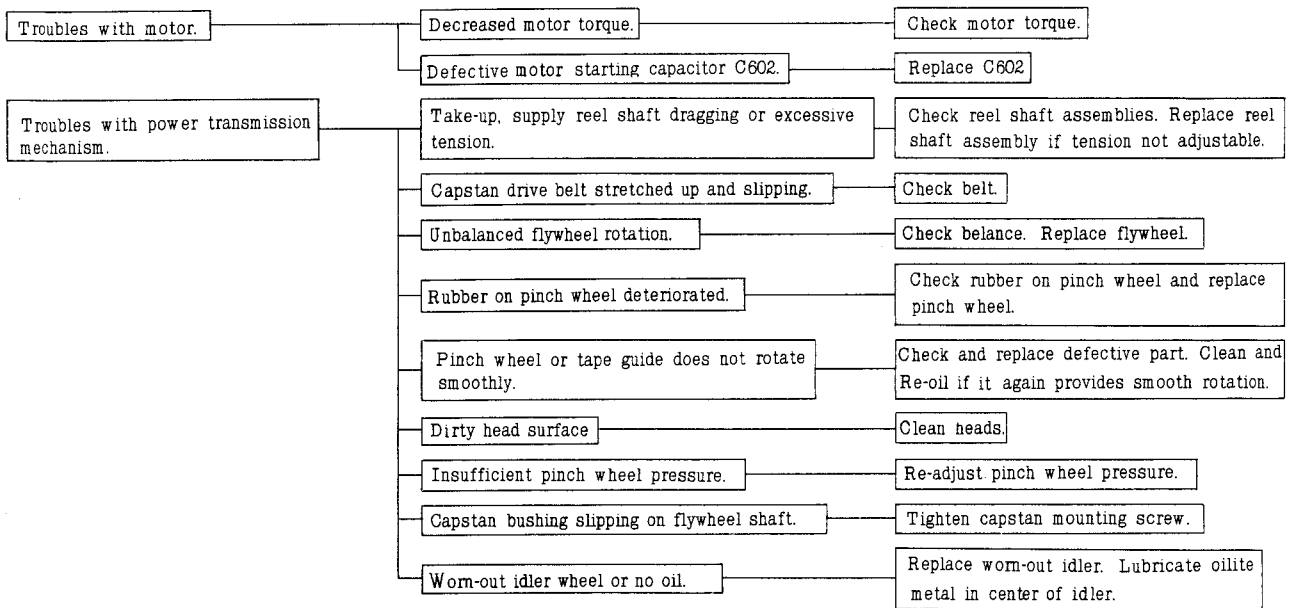

6. Unit does not operate in Fast Forward mode.

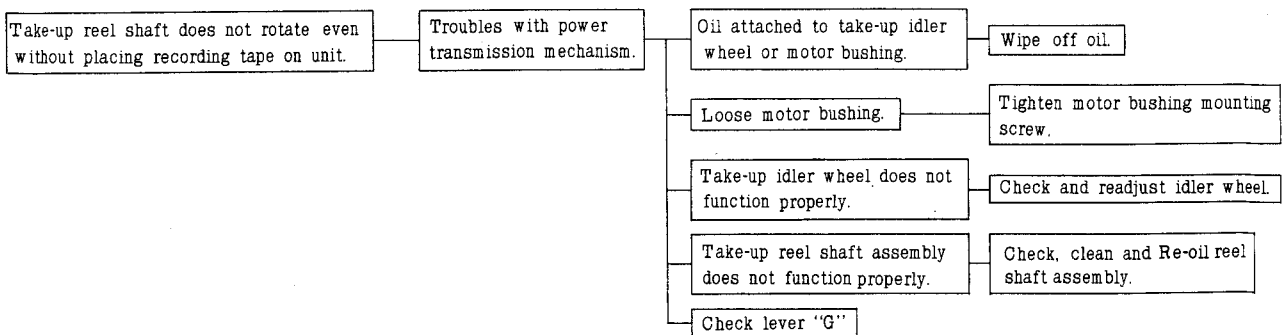

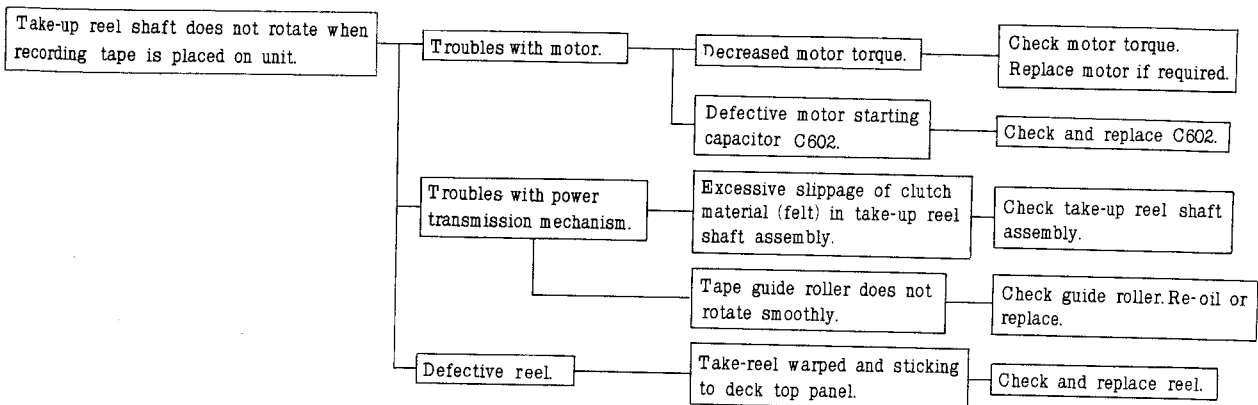

7. Unit does not rewind tape.

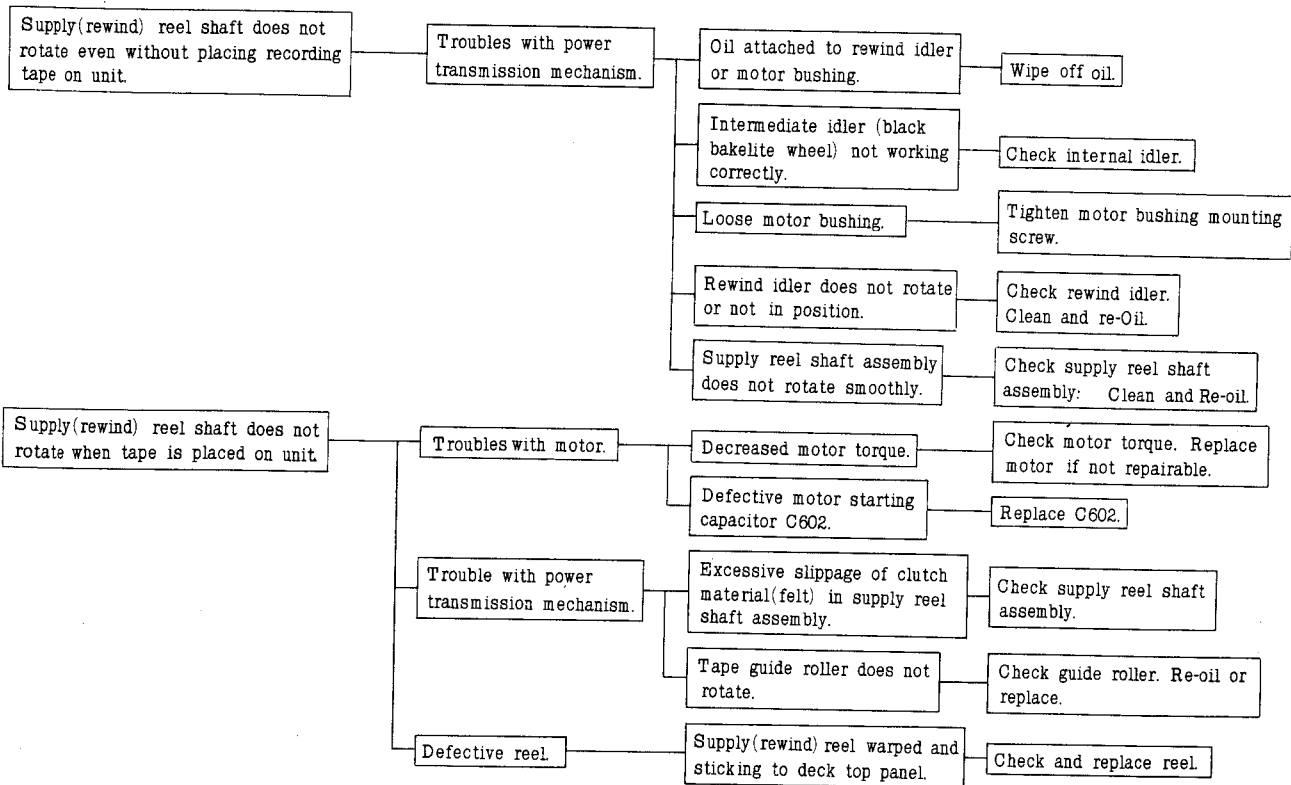

8. Loose tape winding after being placed in Rewind or Fastforward mode.

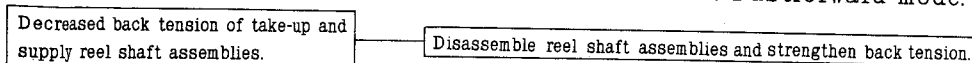

9. Tape spills when stopped from Rewind or Fast Forward mode.

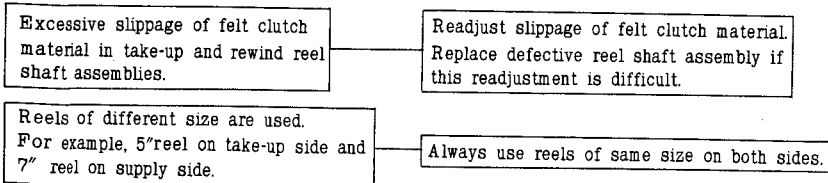

10. Brake does not function properly.

- Worn-out brake shoes. ————— Check and replace brake shoes.
- Oil attached to surface of brake shoes. ————— Wipe off oil with cotton swab soaked in alcohol.
- Loose brake shoes. ————— Tighten brake shoes mounting screw.
- Brake lever does not function properly. ————— Check and re-adjust brake lever.

11. Periodical clack noise when rewinding or fast forwarding tape.

- Worn-out and rugged idler wheel. ————— Check idler wheel.

12. Loud motor vibration.

- Loose motor mounting screw. ————— Tighten mounting screw.
- Defective motor starting capacitor C602. ————— Replace C602.
- Loose oil cover mounting screw. ————— Tighten mounting screw.

13. Squeaking noise when playing tape.

- Dirty head surface. ————— Clean heads.
- Recording tape is being charged with static electricity. ————— Replace recording tape.
- Excessive heat on head surface after continued operation. ————— Check tape head.
- Old and worn-out recording tape. ————— Inspect recording tape.
- Inferior recording tape. ————— Use recording tape of good quality.

14. Automatic stopping device does not function.

- Automatic stop lever moves normally. ————— Micro switch (S603) does not work properly. ————— Check S603.
- Automatic stop lever does not move or sticky. ————— Broken lever spring or lever spring not in position. ————— Check lever spring.
- Automatic stop lever sticks to rear deck panel. ————— Check rear side of deck sub-plate.

15. Cycle change switch does not move.

- No lubricant on cycle conversion lever. ————— Relubricate lever.
- Eccentric or bent cycle conversion lever. ————— Check cycle conversion lever.
- Capstan drive belt not on driving track of flywheel. ————— Check capstan drive belt.
- Loose motor bushing. ————— Tighten mounting screw.
- Loose motor mount screw. ————— Tighten mounting screw.
- Oil on motor bushing or on flywheel. ————— Wipe off oil with cotton swab soaked in alcohol.

MEMO

ME MO

MEMO

1710W

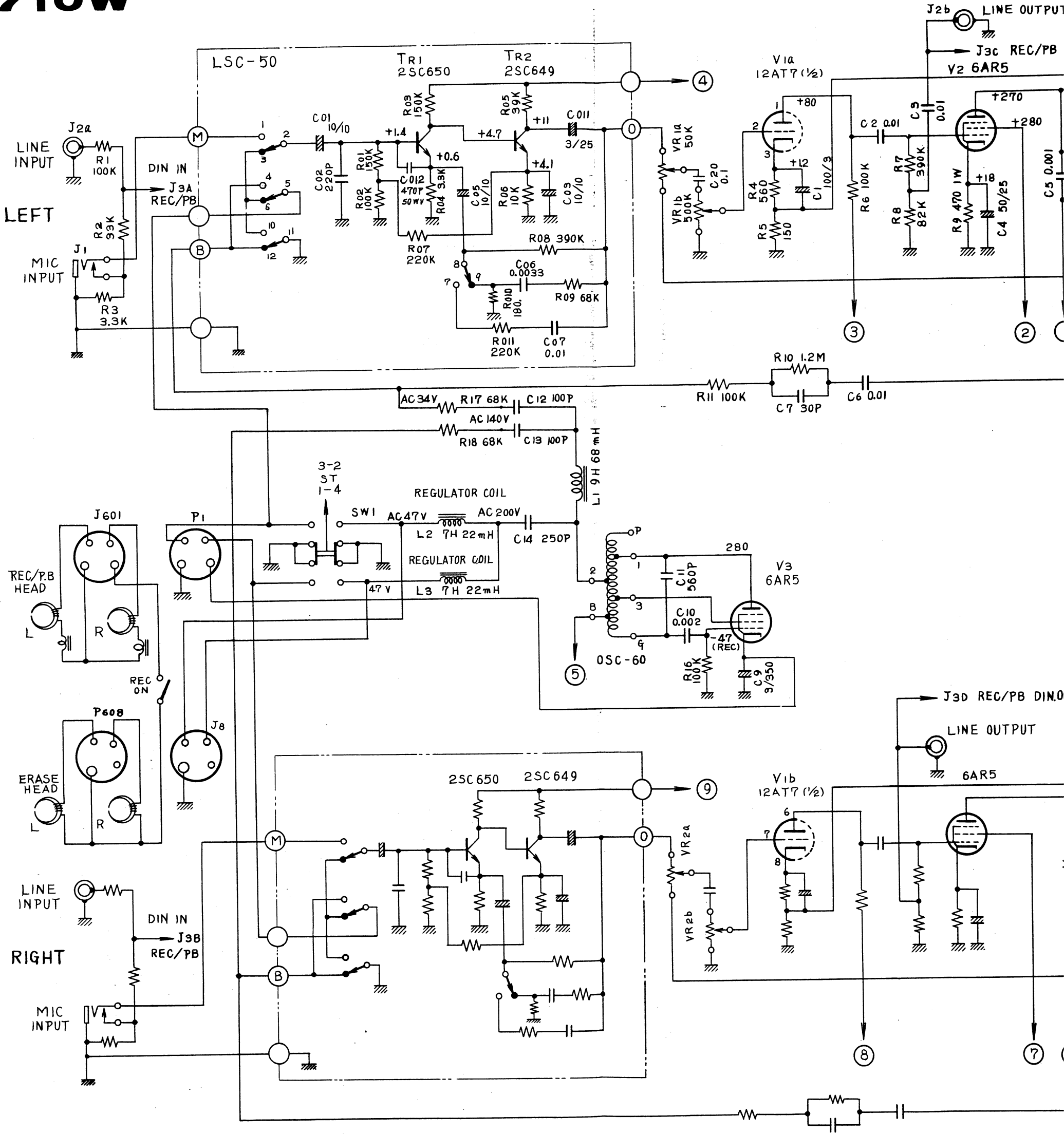

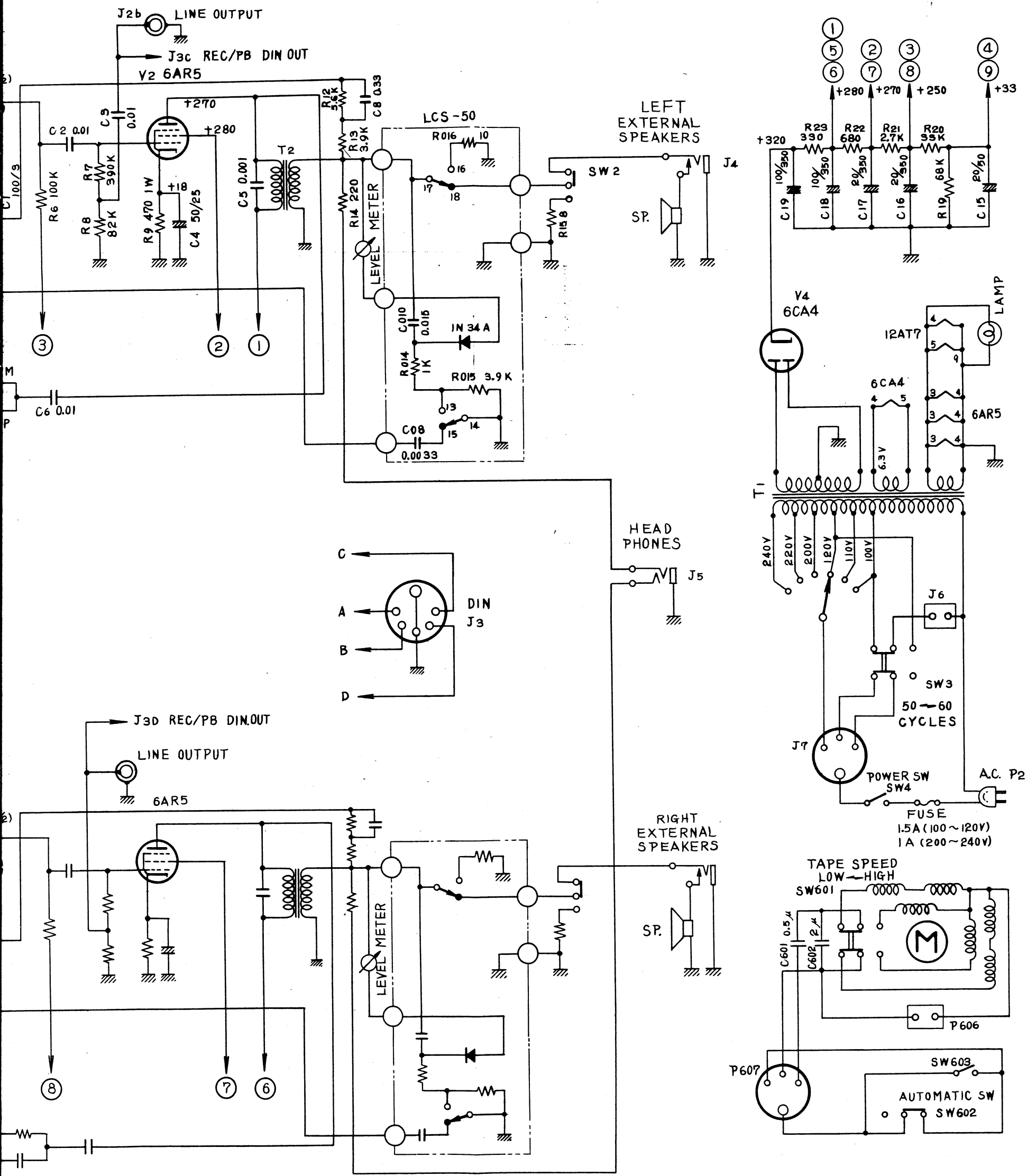

1710W SCHEMATIC 13422544