

SERVICE MANUAL

PARTS LIST

AP-207

MODEL AP-307

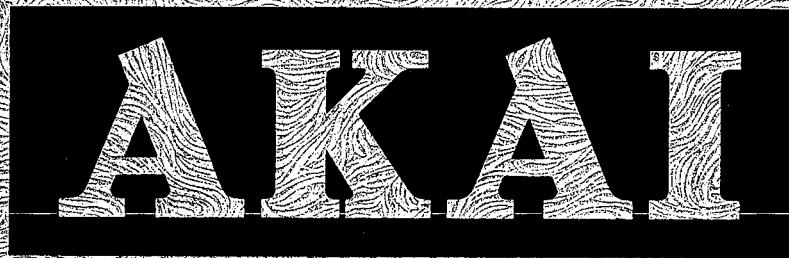

ALSO APPLICABLE TO BLACK MODEL

AP-207
AP-307



AP-207



AP-307

**AKAI DIRECT DRIVE FULLY AUTOMATIC TURNTABLE
AND
QUARTZ LOCK DIRECT DRIVE FULLY AUTOMATIC TURNTABLE**

MODEL AP-207 AP-307

ALSO APPLICABLE TO BLACK MODEL

SECTION 1	SERVICE MANUAL	3
SECTION 2	PARTS LIST	29
SECTION 3	SCHEMATIC DIAGRAM	48

SECTION 1

SERVICE MANUAL

TABLE OF CONTENTS

I. TECHNICAL DATA	4
1. MODEL AP-207	4
2. MODEL AP-307	4
II. DISMANTLING OF UNIT	5
III. CONTROLS	6
1. MODEL AP-207	6
2. MODEL AP-307	7
IV. PRINCIPAL PARTS LOCATION	8
1. MODEL AP-207	8
2. MODEL AP-307	8
V. BLOCK DIAGRAM	9
1. MODEL AP-207	9
2. MODEL AP-307	9
VI. CIRCUIT OPERATION	10
1. GENERAL	10
2. SERVO CIRCUIT	10
3. STROBE LIGHT CIRCUIT	11
VII. MECHANICAL ADJUSTMENT	12
1. STYLUS PRESSURE ADJUSTMENT	12
2. OVERHANG ADJUSTMENT	13
3. SLEEVE POSITION ADJUSTMENT	14
4. ARM LIFTER HEIGHT ADJUSTMENT	14
5. AUTOMATIC ARM CONTROL ADJUSTMENT	15
VIII. ELECTRICAL ADJUSTMENT	16
1. DIRECT DRIVE P.C BOARD ADJUSTMENT	16
2. PLL P.C BOARD ADJUSTMENT	17
IX. CLASSIFICATION OF VARIOUS P.C BOARDS	19
1. P.C BOARD TITLE AND IDENTIFICATION NUMBER	19
2. COMPOSITION OF VARIOUS P.C BOARDS	20

I. TECHNICAL DATA

1. MODEL AP-207

TURNTABLE	314 mm aluminium alloy die-cast
DRIVE SYSTEM	Direct Drive, Fully Automatic
MOTOR	DC Servo Motor, Geared Motor for Tone Arm Drive
SPEED & PITCH CONTROL	33-1/3 and 45 rpm $\pm 2.5\%$
SPEED ACCURACY	1,000 Hz $\pm 0.15\%$
WOW AND FLUTTER	0.035% (DIN), 0.025% (JIS)
RUMBLE	Better than 49 dB (DIN A), 70 dB (DIN B)
STONE ARM	Static balanced type with Anti-skating Adjuster
ARM LENGTH	220 mm
STYLUS PRESSURE ADJUSTMENT RANGE	0 to 3 grams
APPLICABLE CARTRIDGE WEIGHT	4 to 12 grams
ARM LIFTER	Oil-damped
OVERHANG	15 mm
OFFSET ANGLE	22°30'
HORIZONTAL TRACKING ERROR ANGLE	$\pm 2^\circ$
SHELL WEIGHT	7.8 grams
POWER REQUIREMENTS	120V, 60 Hz for U.S.A. and Canada 220V, 50 Hz for European countries 240V, 50 Hz for U.K. and Australia 110 to 120V, 220 to 240V switchable 50/60 Hz for other countries
DIMENSIONS	440(W) x 158(H) x 350(D) mm
WEIGHT	8.1 kg

* For improvement purposes, specifications and design are subject to change without notice.

2. MODEL AP-307

TURNTABLE	314 mm aluminium alloy die-cast
DRIVE SYSTEM	Quartz Lock Direct Drive, Fully Automatic
MOTOR	DC Servo Motor, Geared Motor for Tone Arm drive
SPEED & PITCH CONTROL	33-1/3 and 45 rpm $\pm 2.5\%$
SPEED ACCURACY	1,000 Hz $\pm 0.08\%$
WOW AND FLUTTER	0.035% (DIN), 0.025% (JIS)
RUMBLE	Better than 49 dB (DIN A), 70 dB (DIN B)
MOMENT OF INERTIA	230 kg.cm ²
STONE ARM	Static balanced type with Anti-skating Adjuster
ARM LENGTH	220 mm
STYLUS PRESSURE ADJUSTMENT RANGE	0 to 3 grams
APPLICABLE CARTRIDGE WEIGHT	4 to 12 grams
ARM LIFTER	Oil-damped
OVERHANG	15 mm
OFFSET ANGLE	22°30'
HORIZONTAL TRACKING ERROR ANGLE	$\pm 2^\circ$
SHELL WEIGHT	7.8 grams
POWER REQUIREMENTS	120V, 60 Hz for U.S.A. and Canada 220V, 50 Hz for European countries 240V, 50 Hz for U.K. and Australia 110 to 120V, 220 to 240V switchable 50/60 Hz for other countries.
DIMENSIONS	440(W) x 158(H) x 350(D) mm
WEIGHT	8.6 kg

* For improvement purposes, specifications and design are subject to change without notice.

II. DISMANTLING OF UNIT

In case of trouble, etc. necessitating dismantling, please dismantle in the order shown in the photographs. Reassemble in reverse order.

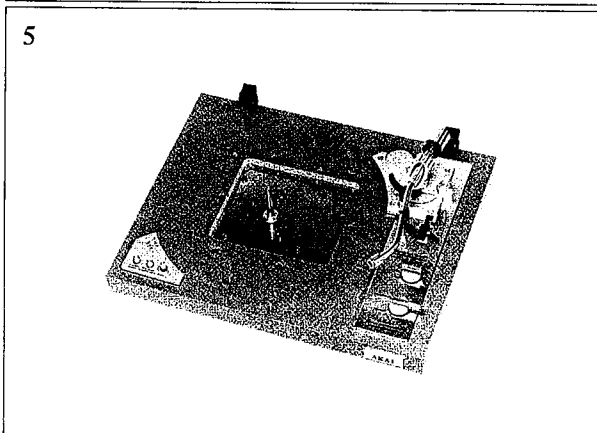
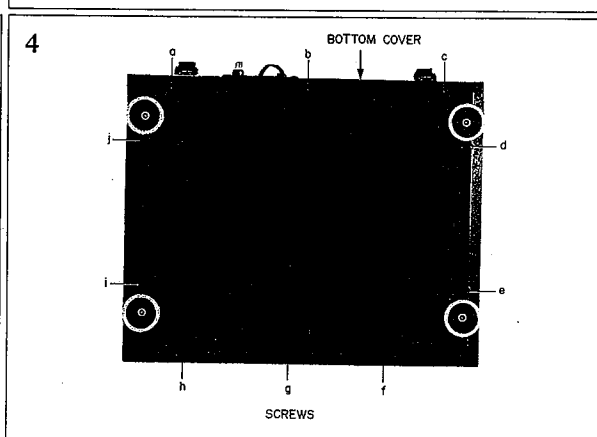
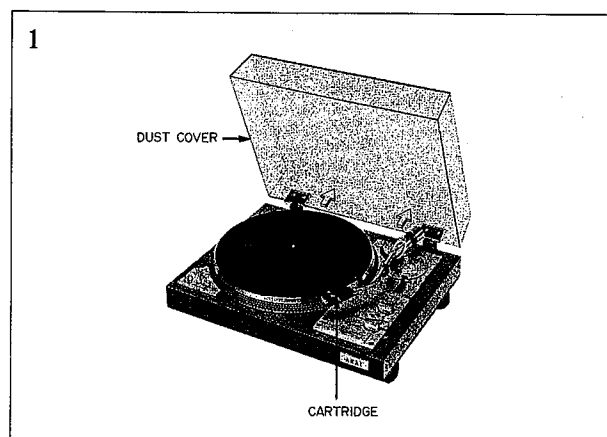

NOTE: Photos of dismantling are those of AP-307, but the order applies to AP-207 also.

III. CONTROLS

1. MODEL AP-207

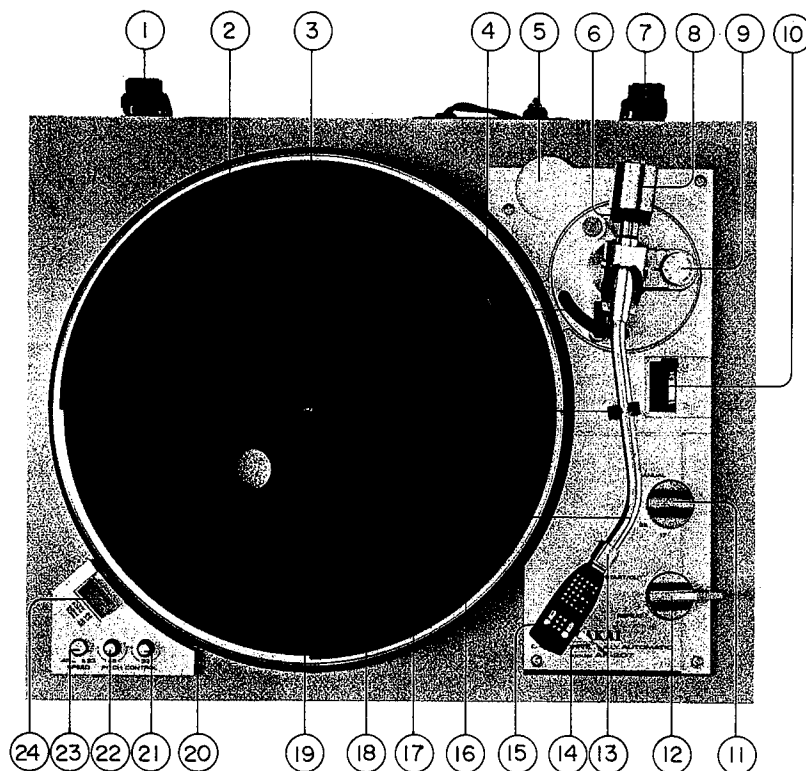

Fig. 1

- | | |
|---------------------------------------|--|
| 1. HINGE | 13. LOCKING NUT |
| 2. TURNTABLE PLATTER | 14. CARTRIDGE SHELL FINGER LEVER |
| 3. SPINDLE | 15. CARTRIDGE SHELL |
| 4. TONE ARM LIFTER | 16. TONE ARM |
| 5. POSITION FOR 45 rpm ADAPTOR | 17. TONE ARM REST |
| 6. STYLUS PRESSURE SCALE RING | 18. RUBBER MAT |
| 7. HINGE | 19. OVERHANG ADJUSTMENT SCALE |
| 8. MAIN WEIGHT | 20. STROBE MARKINGS |
| 9. ANTI-SKATING ADJUSTOR | 21. 33 rpm PITCH CONTROL |
| 10. TONE ARM LIFTER LEVER ▼ UP ▼ DOWN | 22. 45 rpm PITCH CONTROL |
| 11. DISC SIZE SELECTOR/MANUAL | 23. 33/45 rpm SPEED SELECTOR 33 ▲ 45 ▼ |
| 12. START/CUT REPEAT LEVER | 24. BUILT-IN STROBE LIGHT |

2. MODEL AP-307

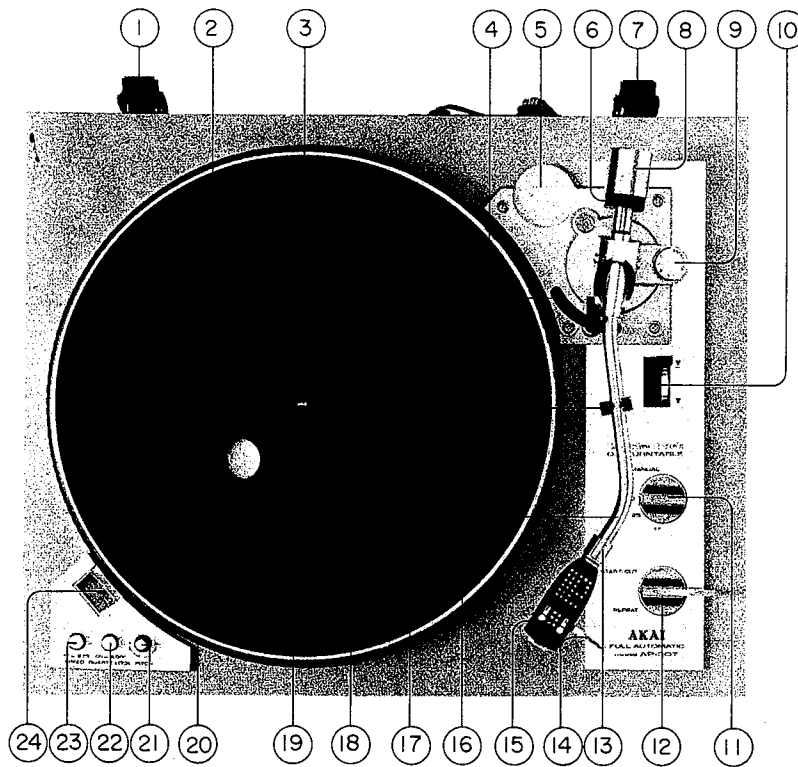

Fig. 2

- | | |
|---|-------------------------------------|
| 1. HINGE | 13. LOCKING NUT |
| 2. TURNTABLE PLATTER | 14. CARTRIDGE SHELL FINGER LEVER |
| 3. SPINDLE | 15. CARTRIDGE SHELL |
| 4. TONE ARM LIFTER | 16. TONE ARM REST |
| 5. POSITION FOR 45 rpm ADAPTOR | 17. TONE ARM |
| 6. STYLUS PRESSURE SCALE RING | 18. RUBBER MAT |
| 7. HINGE | 19. OVERHANG ADJUSTMENT SCALE |
| 8. MAIN WEIGHT | 20. STROBE MARKINGS |
| 9. ANTI-SKATING ADJUSTER | 21. PITCH CONTROL SWITCH |
| 10. TONE ARM LIFTER LEVER ∇ UP ∇ DOWN | 22. QUARTZ LOCK SWITCH |
| 11. DISC SIZE SELECTOR/MANUAL | 23. 33/45 rpm SPEED SELECTOR SWITCH |
| 12. START/CUT REPEAT LEVER | 24. BUILT-IN STROBE LIGHT |

IV. PRINCIPAL PARTS LOCATION

1. MODEL AP-207

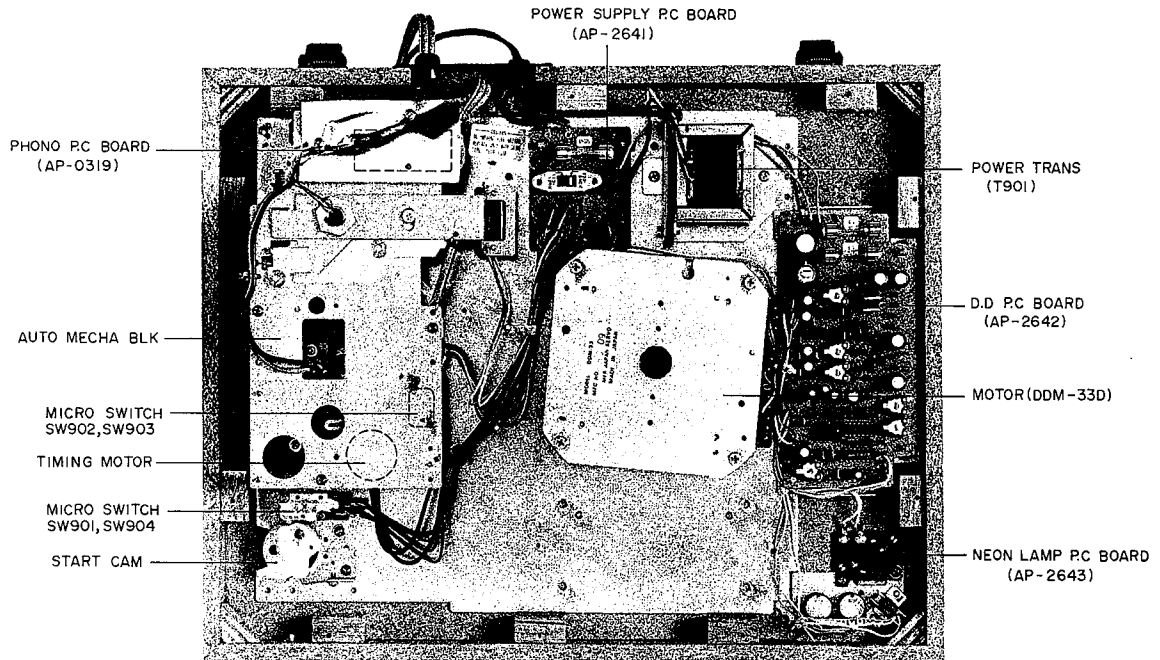

Fig. 3 Bottom View

2. MODEL AP-307

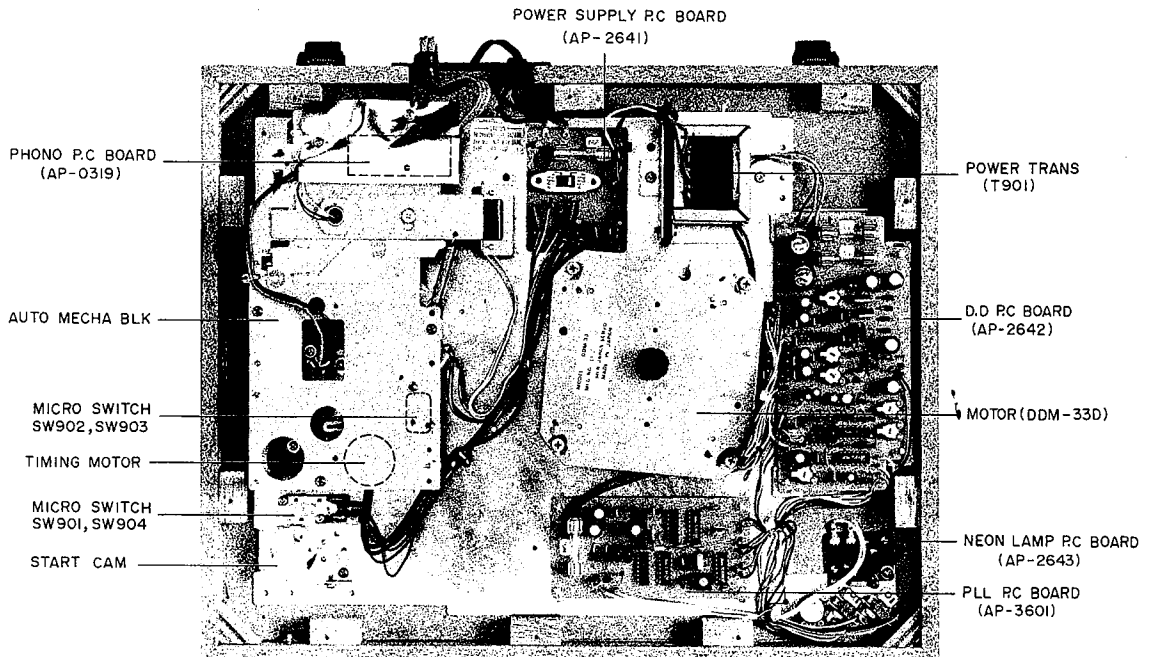

Fig. 4 Bottom View

V. BLOCK DIAGRAM

1. MODEL AP-207

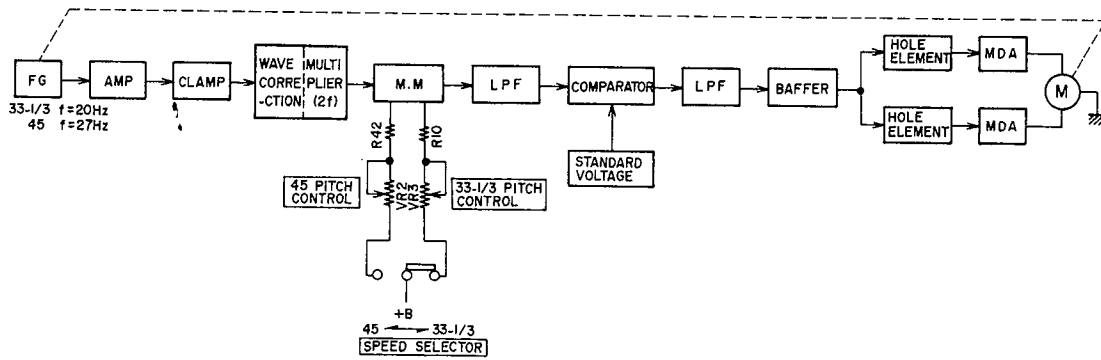

Fig. 5

2. MODEL AP-307

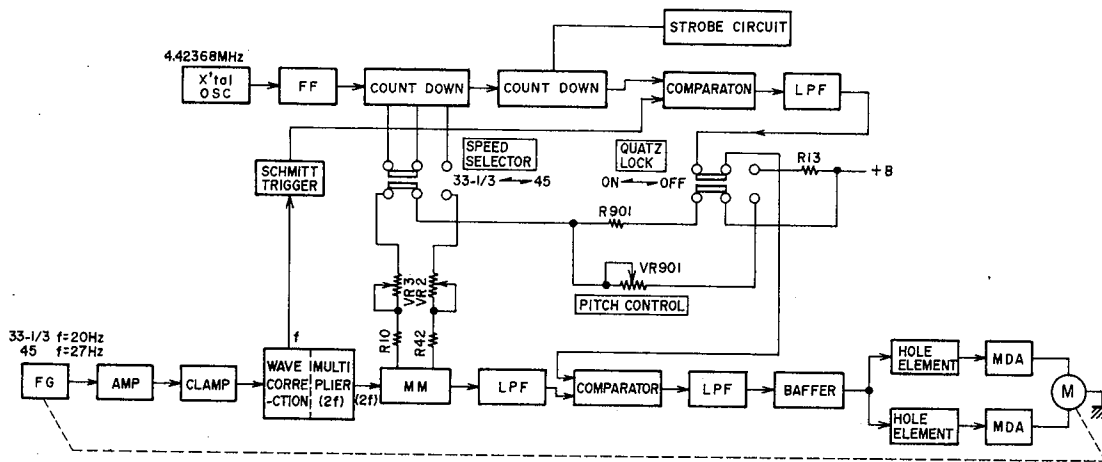

Fig. 6

VI. CIRCUIT OPERATION

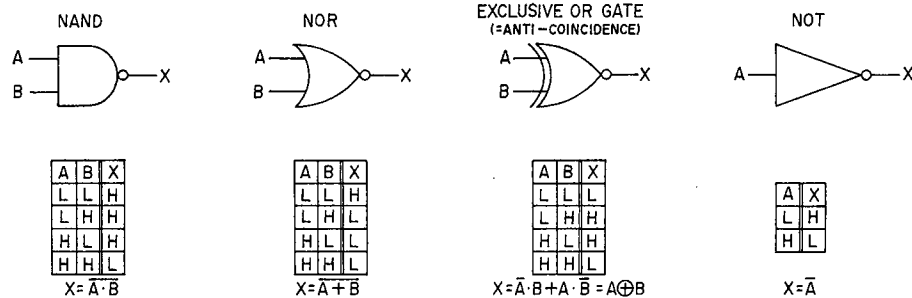

Fig. 7

1. GENERAL

The AP-207 has a D.D (Direct Drive) P.C Board (AP-2642) that contains a FG (Frequency Generator) the signal output of which controls the motor.

The AP-307 has a PLL (Phase-Locked Loop) P.C Board (AP-3601) in addition to the electrical circuit in the AP-207.

The PLL Circuit in the AP-307 consists of a Quartz Lock Circuit and a Stroboscope Circuit. The stroboscope circuit flashes the neon tube NE901 in synchronism with the frequency to which the crystal oscillator frequency is accurately counted down, while the neon tube NE901 in the AP-207 is activated by the line power to flash the stroboscope patterns on the turntable.

2. SERVO CIRCUIT

1) Operation when the Quartz Lock Switch SW903 is OFF

(Refer to the D.D. Circuit schematic diagram of the AP-307.)

The motor incorporates a FG coil that produces FG signal as the motor rotates. The FG signal frequency is 20 Hz for 33-1/3 rpm and 27 Hz for 45 rpm. The FG signal is magnified through IC1 (4 to 8). The magnified FG signal is clamped to positive side by R40 and VR1, and enters IC2 ①. In IC2, the signal is waveform-shaped and frequency-doubled. The doubled signal is fed to IC3 ①, as an input to Mono Multi.

The Mono Multi provides a characteristic that its stable state is inverted by an external trigger into the unstable state, where it remains for a predetermined time before returning to the original stable state. The pulse output of Mono Multi IC3 ⑩ is smoothed by C7 to DC which is led to IC1 ② as the voltage to be compared. When the Quartz Lock Switch SW903 is off, a reference voltage is applied to IC1 ③.

The voltage at IC1 ② is compared with the reference voltage at IC1 ③, and the output appears at IC1 ①. The output at IC1 ① is passed through the phase correction circuit, consisting of

C9 through C11 and R18 through R20, to TR1. TR1. TR1 makes current flow through the Hall Elements H1 and H2, which are installed in position under the rotor magnet of the motor. The voltage developed across each Hall element is in proportion to the current flowing through the Hall Elements and the strength of the magnetic field of the rotor magnet.

The voltages output of the two Hall elements are supplied to the motor drive amplifier, consisting of IC4 (4 to 8), TR2 and TR3 and IC4 (1 to 3), TR4, and TR5, to control motor speed.

If the motor speed is made late by some cause, the FG signal frequency becomes lower. The width of the pulse output of the IC3 Mono Multi becomes wider. This increases the comparison voltage at IC1 ②, which in turn raises the voltage output of IC1 ①. The result is an increase of the current flowing through TR1 and the Hall elements H1 and H2. The current increase the motor drive amplifier so as to make the motor speed fast.

2) Operation when the Quartz Lock Switch SW903 is ON

(Refer to the PLL Circuit schematic diagram of the AP-307)

The 4.42368 MHz signal generated by the crystal oscillator is delivered through TP-1 to IC2 ③. The Flip-Flop in IC2 halves the oscillation frequency of 4.42368 MHz. The frequency-halved signal is delivered as a clock pulse to IC3 ⑤, which counts it down to 1/27 (81.920 Hz) for 33-1/3 rpm or 1/20 (110.592 Hz) for 45 rpm according as set by the Speed Selector Switch SW902. The count-down signal, which appears at IC3 ⑩, is further counted down to 20 Hz for 33-1/3 rpm or 27 Hz for 45 rpm at IC4 ①. This output signal of IC4 ① enters the comparison circuit in IC5 ⑦, as a set pulse.

On the other hand, the FG signal fed through the D.D circuit to the PLL circuit is waveform-shaped by the Schmitt trigger in IC1 (10 to 13), and is fed through IC1 ⑩, and R3 to IC5 ⑧ as the reset

pulse. The reset pulse of 20 Hz for 33-1/3 rpm or 27 Hz for 45 rpm shaped from the FG signal is compared with the above-mentioned set pulse entering IC5 ⑦, and the output appears at IC5 ③. The output pulse is smoothed by the low-pass filter, consisting of C9, C10 and R5 through R7, and enters IC5 ②, then the inverted output is fed from IC5 ①. The output of IC5 ① fed through R8 and SW903 to IC1 ③, in the D.D circuit as the reference voltage. In short, when the Quartz Lock Switch SW903 is off, the reference voltage is made of the +B voltage, while when it is on, the pulse made of the FG signal is compared with the pulse generated by the crystal oscillator to produce the reference voltage. The succeeding operation is similar to the one when the Quartz Lock Switch is off.

3. STROBE LIGHT CIRCUIT

(Refer to the PLL Circuit schematic diagram of the AP-307)

The 4.42368 MHz signal generated by the crystal oscillator is delivered through TP-1 to IC2 ③. The Flip-Flop in IC2 halves the oscillation frequency to 2.21184 MHz. The halved signal is fed from IC2 ①, to IC3 ⑮. IC3 counts the frequency down to 1/27 for 33-1/3 rpm or 1/20 for 45 rpm.

The count-down signal is fed from IC3 10, to IC4 ⑩.

IC4 further counts the signal down to 160 Hz at IC4 ⑫, 320 Hz at IC4 ⑬ and 80 Hz at IC4 ⑭ for 33-1/3 rpm or to 216 Hz, 432 Hz and 108 Hz for 45 rpm, respectively. These output signals are input to the NOR circuit of IC6 (1 to 5). The NOR circuit outputs from IC6 ①, 80 Hz signal for 33-1/3 rpm or 108 Hz signal for 45 rpm. The signal is fed through R10 to TR1 to turn on and off, which flashes the neon lamp NE901.

Reference: Logic Symbols and Their Truth Table

VII. MECHANICAL ADJUSTMENT

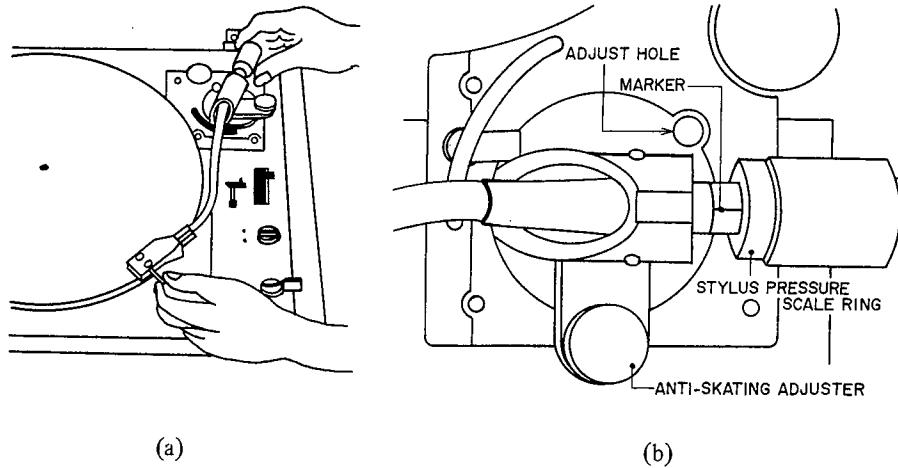

Fig. 8

1. STYLUS PRESSURE ADJUSTMENT

- 1) Plug the power cord into a wall outlet of rated voltage.
- 2) Unlock tone arm.
- 3) Bring the tone arm over to the turntable to start the motor. Pull the Start/Cut lever toward you and release immediately.
- 4) Wait until the tone arm lift is completely lowered.
- 5) Keep the tone arm between the turntable and arm rest without touching either.
- 6) Rotate the main weight backward until the tone arm is in perfect horizontal balance. (Zero balance is attained.)

CAUTION 1: Be sure that the Anti-skating Adjuster is set to zero.

2: Be careful not to damage the stylus.

- 7) Without moving the main weight, turn the stylus pressure scale ring only to match the "0" mark with the marker on the weight shaft (see Fig. 8).
- 8) Turn the main weight counterclockwise (as viewed from the front) with the stylus pressure scale ring until the marker on the weight shaft corresponds to the desired stylus pressure on the scale.

NOTES 1: The AP-207 and AP-307 Black and Silver Panel Models do not come equipped with cartridge.

2: If there is outside interference, it is needed that the stylus pressure should be increased for stable playback. The range of adjustable stylus pressure is from 0 to 3 grams.

- 9) Set the Anti-skating Adjuster to correspond to the stylus pressure. (Fine adjust if necessary.)

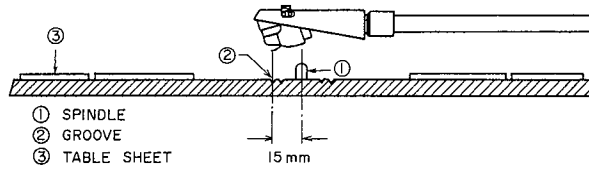
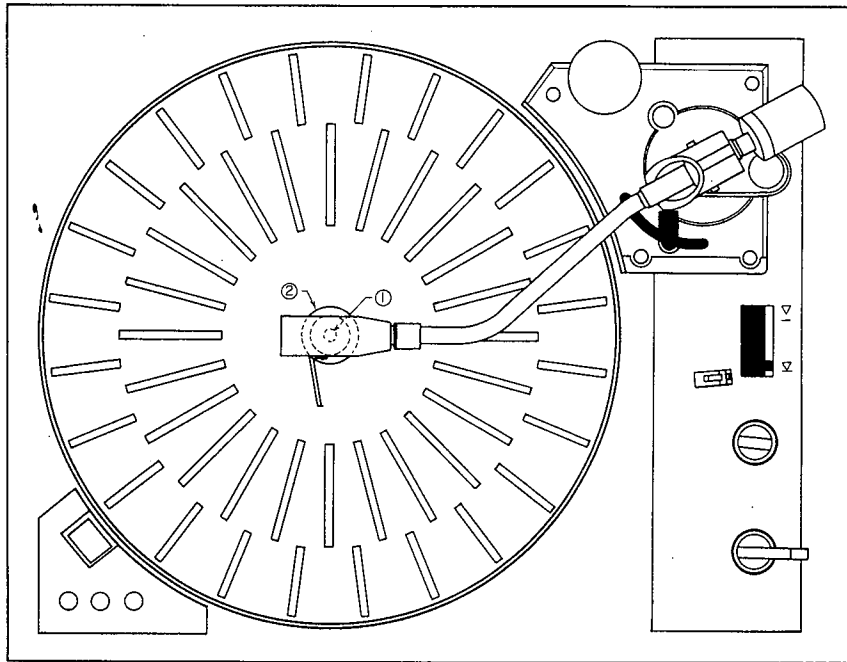

Fig. 9

2. OVERHANG ADJUSTMENT (Refer to Fig. 9)

The distance between the turntable spindle and the stylus when the tone arm is at the center of the turntable is called overhang. Different cartridges require different overhang adjustments. For your convenience, the rubber turntable mat had indicator groove at the center for easy overhang adjustment. Bring the tone arm to the center of the turntable. Adjust the cartridge position in the cartridge shell so that the stylus position is even with the outside groove ring. The cartridge position is adjustable by resetting the screws on the cartridge shell.

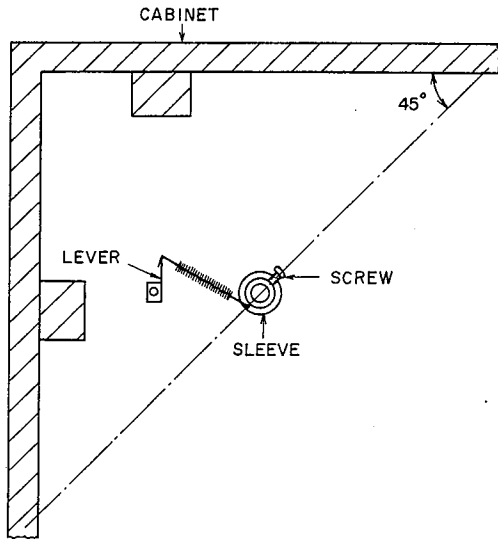

Fig. 10

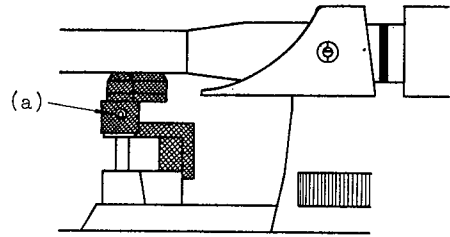

Fig. 11

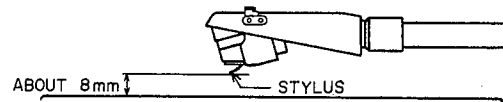

Fig. 12

3. SLEEVE POSITION ADJUSTMENT

(Refer to Fig. 10)

The sleeve position adjusts anti-skating feature.

- 1) Put the tone arm in the "stop" state, or on the arm rest.
- 2) Set the sleeve, located between the PU Plate and the chassis, to approximately 45° position as shown in Fig. 10.

4. ARM LIFTER HEIGHT ADJUSTMENT

(Refer to Fig. 11 and Fig. 12)

- 1) Loosen the set screw (a).
- 2) Adjust the tone arm lifter stylus is around 8 mm above the disk surface when the tone arm is put on the tone arm lifter.
- 3) Make certain that silicon oil remains on the lifter plate. If not, apply it to assure smooth tone arm movement.

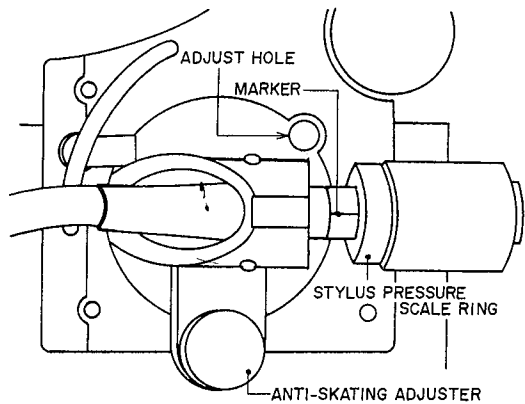

Fig. 13

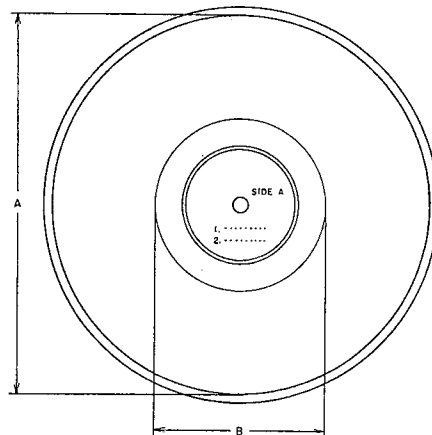

Fig. 14

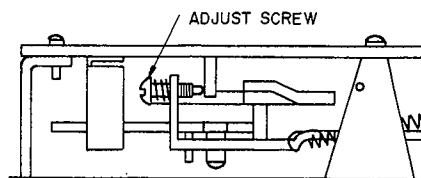

Fig. 15

5. AUTOMATIC ARM CONTROL ADJUSTMENT (Refer to Figs. 9, 10 and 11)

1) Stylus Lead-in Adjustment

- Bring the tone arm toward the center of the turntable until the adjust screw is seen through the adjust hole located as in Fig. 13.
- Adjust the adjust screw until the stylus is dropped down onto an appropriate point in the lead-in groove of a disk.

NOTE: The range A of lead-in groove on which the stylus is to be dropped down is (refer to Fig. 14):

- 293 to 298 mm diameter for 30 cm disk.
- 242 to 247 mm diameter for 25 cm disk.
- 168 to 173 mm diameter for 17 cm disk.

2) Stylus Lead-out Adjustment

- Hold the tone arm put on the arm rest.
- For a 30 or 25 cm disk, adjust the adjust screw seen through the adjust hole (see Fig. 13) until the stylus is lifted up at an appropriate point in the lead-out groove. For a 17 cm disk, remove the bottom cabinet, and similarly adjust the adjust screw shown in Fig. 15.

NOTE: The range B of lead-out groove on which the stylus is to be lifted up is (refer to Fig. 14):

- 109 to 115 mm diameter for 30 and 25 cm disks.
- 98 to 106 mm diameter for 17 cm disk.

CAUTION: Do not use any disk or phono sheet other than the one complying with the JIS standard or equivalent disk for stylus lead-in and lead-out adjustments.

VIII. ELECTRICAL ADJUSTMENT

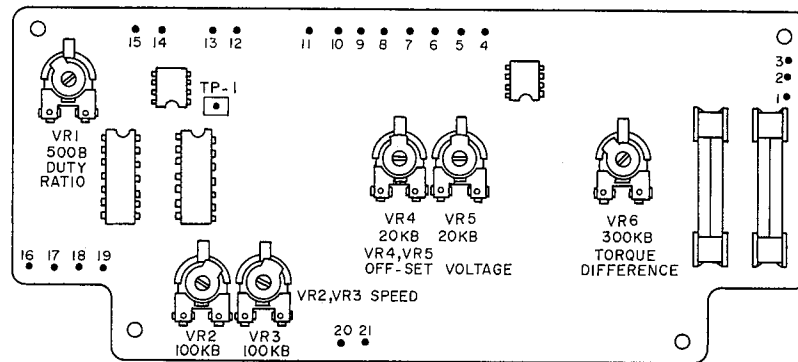

Fig. 16

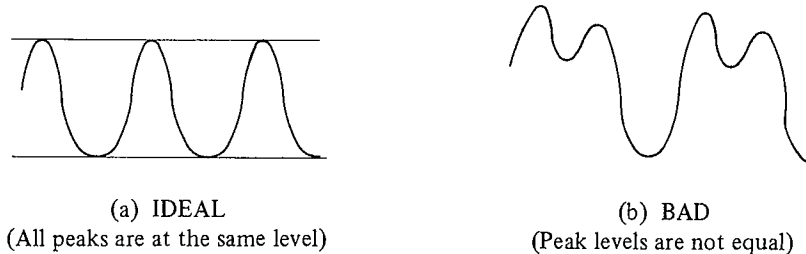

Fig. 17

1. DIRECT DRIVE P.C BOARD ADJUSTMENT

1) Off-set Voltage Adjustment (VR4, VR5)

- a) Disconnect the motor, or make open pins 4 through 11 and 14 and 15, leaving the other pins connected.
- b) For VR4, connect a digital DC voltmeter to pins 6 and 8 (ground).
- c) Shortcircuit pins 9 and 10.
- d) Move the tone arm to turn the power on.
- e) Adjust VR4 until the output at pin 6 is $0V \pm 10$ mV for the AP-2-7 and 80 ± 10 mV for the AP-307.
- f) For VR5, in turn, connect the digital DC voltmeter to pins 7 and 8 (ground).
- g) Shortcircuit pins 4 and 5.
- h) Adjust VR5 until the output at pin 7 is $0V \pm 10$ mV for the AP-207 and 80 ± 10 mV for the AP-307.

2) Duty Ratio Adjustment to 1:1 (VR1)

- a) Connect an oscilloscope to TP-1.
- b) Set the SPEED selector to the "33-1/3" position.
For the AP-307, release the QUARTZ LOCK button to the OFF position.
- c) Move the tone arm to rotate the motor.
- d) Adjust VR1 until the oscilloscope shows such a waveform as illustrated below.

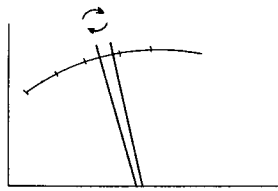

Fig. 18

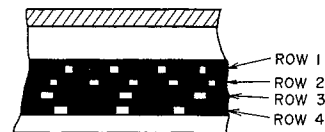

Fig. 19

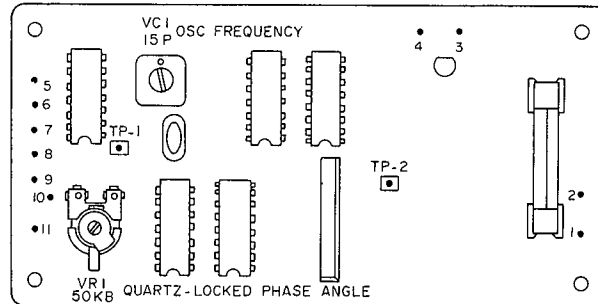

Fig. 20

3) Torque Difference Adjustment (VR6)

- Connect a dual-channel AC voltmeter to pins 6, 7 and 8 (common ground).
- Set the SPEED selector to the "33-1/3" position. For the AP-307, release the QUARTZ LOCK button to the OFF position.
- Move the tone arm to rotate the motor.
- Adjust VR6 until the outputs at pins 6 and 7 are of the same level.

NOTE: As the output frequency is as low as a few Hz, the voltmeter needles will vibrate minutely. In the state of correct adjustment, the two needles will seem intertwining as shown below.

CAUTION: In this adjustment, the voltages are determined by the motor rpm so they should only be matched in as much as that vary.

4) Speed Adjustment (VR2, VR3)

- Set the SPEED selector to the "33-1/3" position. For the AP-307, release the QUARTZ LOCK button to the OFF position.
- Set the PITCH control to the center.
- Move the tone arm to rotate the motor.
- For the AP-207, adjust VR3 until the stroboscope pattern on the first line for 50 Hz power or the second line for 60 Hz power is seen standing still. For the AP-307, also adjust VR3 until the single stroboscope pattern is seen standing still.

- In turn, reset the SPEED selector to the "45" position.
- For the AP-207, similarly adjust VR2 until the stroboscope pattern on the third line for 50 Hz power or the fourth line for 60 Hz power is seen standing still.

NOTE: It is important that the pattern should not rotate in the reverse direction of the motor, or rightward as in the above line drawing.

2. PLL P.C BOARD ADJUSTMENT

(AP-307 Only)

1) Oscillation Frequency Adjustment (VC1)

- Connect a frequency counter to TP-1 and pin 5 (ground).
- Set the SPEED selector to the "33-1/3" position.
- Move the tone arm to turn power on.
- Adjust VC1 until the frequency counter reads $4,423,680 \pm 10$ Hz.

CAUTION: For turning VC1, use a RF adjusting screwdriver.

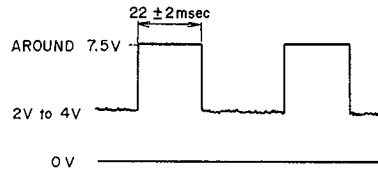

Fig. 21

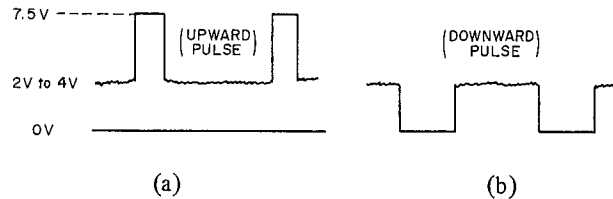

Fig. 22

2) Quartz-Locked Phase Angle Adjustment (VR1)

- Connect an oscilloscope to TP-2 and pin 5 (ground).
- Release the SPEED selector to the "33-1/3" position.
- Depress the QUARTZ LOCK button in (ON).
- Move the tone arm to turn power on.
- Adjust VR1 until the width of the upward pulse above 2 to 4V is 22 ± 2 msec when the stroboscope pattern is seen standing still, as Fig. 20.

CAUTION: The upward pulse around +7.5V shown above may change to downward pulse (0V) below 2 to 4V with VR1 turned as Fig. 22(a). Be careful not to measure the width of the downward pulse. It can be checked in a simple way as the upward pulse will change to a downward pulse when some pressure is applied to the platter by hand.

This adjustment must be made with an oscilloscope of 1 M ohm input impedance using 10:1 probe and must be conducted in the DC mode. When the input impedance is other than 1 M ohm and the waveforms are observed in the AC mode, pulse width changes and correct adjustment cannot be made.

IX. CLASSIFICATION OF VARIOUS P.C BOARDS

1. P.C BOARD TITLE AND IDENTIFICATION NUMBER

P.C Board Title	P.C Board Number	Utilizing Model
Power Supply P.C Board	AP-2641	AP-207, AP-307
D.D P.C Board	AP-2642	AP-207, AP-307
Neon Lamp P.C Board	AP-2643	AP-207, AP-307
PLL P.C Board	AP-3601	AP-307

2. COMPOSITION OF VARIOUS P.C BOARDS

1) D.D. P.C BOARD AP-2642

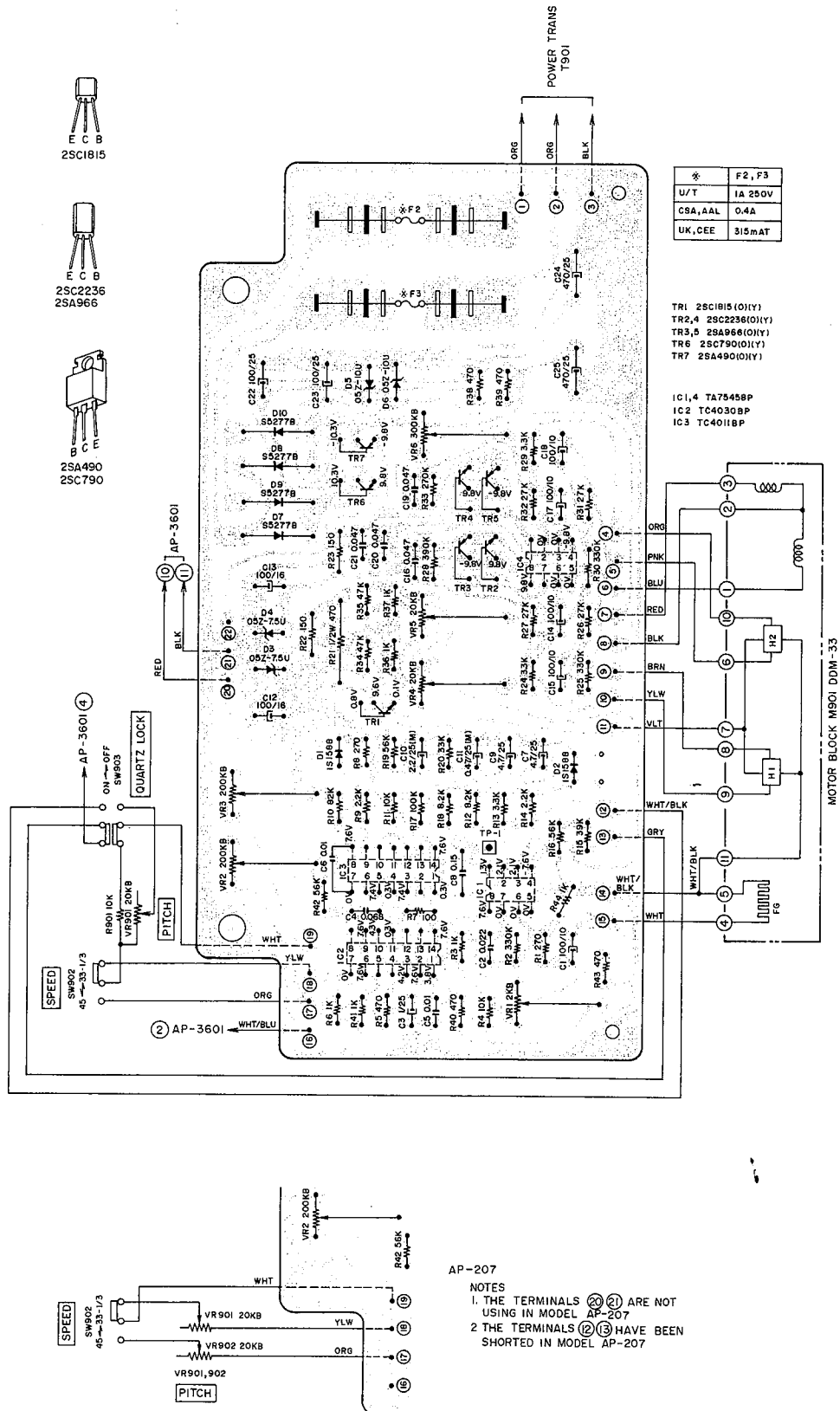

2) PLL P.C BOARD AP-3601 (Model AP-307 only)

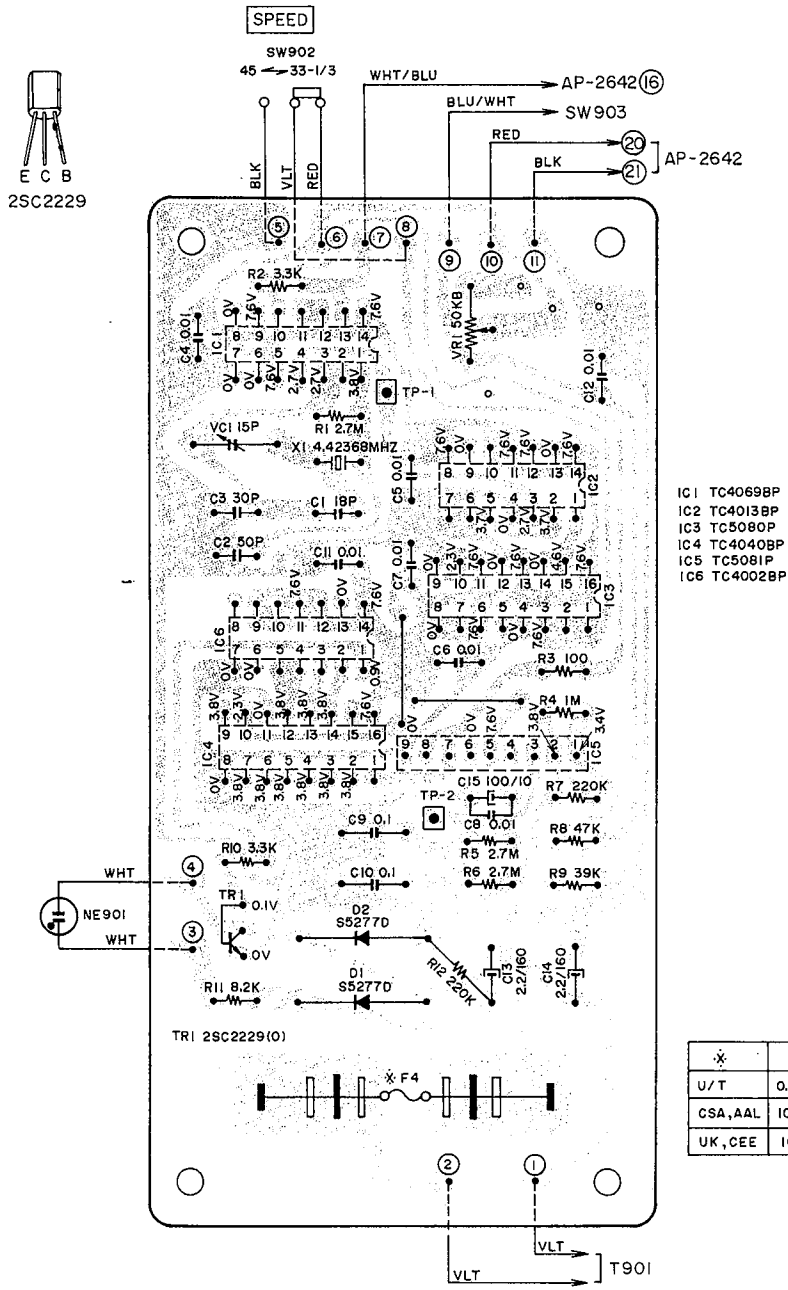

✱	F4
U/T	0.1A 250V
CSA, AAL	100mA 125V
UK, CEE	100 mA T

3) POWER SUPPLY P.C BOARD AP-2641 (U/T)

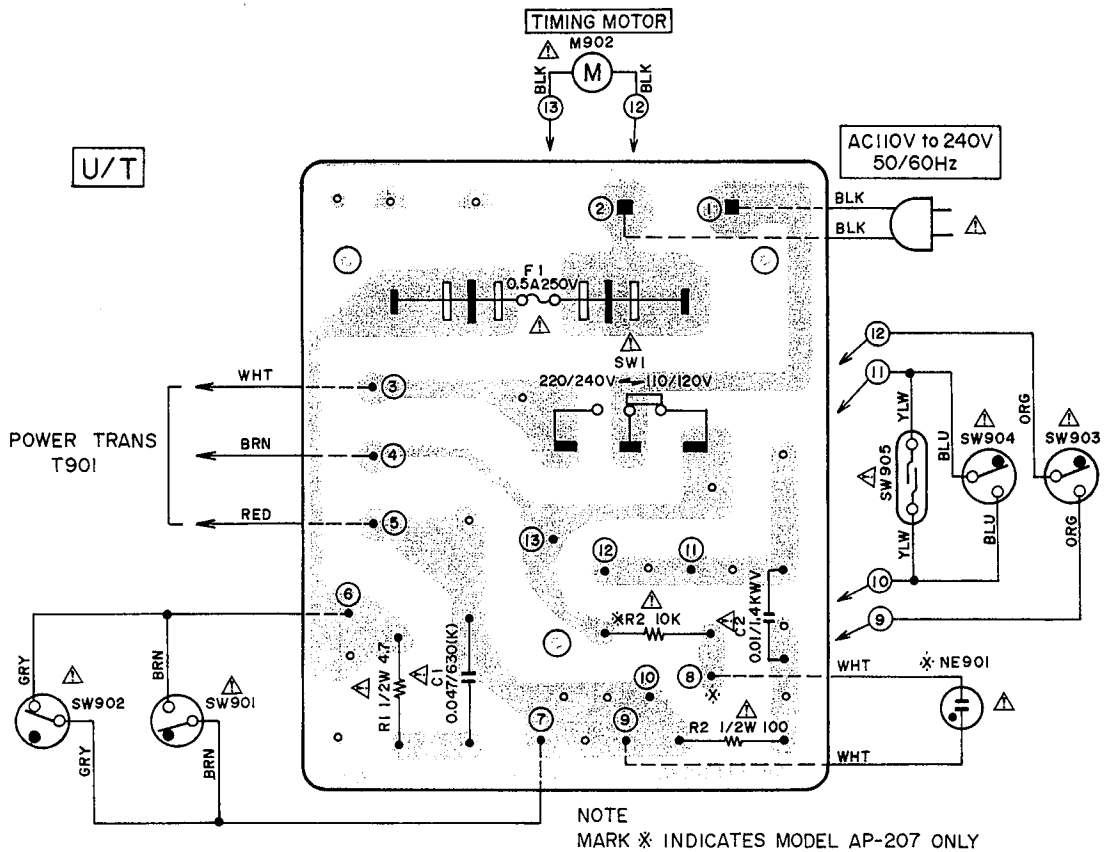

WARNING: ⚠ INDICATES SAFETY CRITICAL COMPONENTS. FOR CONTINUED SAFETY, REPLACE SAFETY CRITICAL COMPONENTS ONLY WITH MANUFACTURER'S RECOMMENDED PARTS.
 AVERTISSEMENT: ⚠ IL INDIQUE LES COMPOSANTS CRITIQUES DE SÛRETÉ. POUR MAINTENIR LE DEGRÉ DE SÛRETÉ DE L'APPAREIL, NE REMPLACER LES COMPOSANTS DONT LE FONCTIONNEMENT EST CRITIQUE POUR LA SÛRETÉ QUE PAR DES PIÈCES RECOMMANDÉES PAR LE FABRICANT.

4) POWER SUPPLY P.C BOARD AP-2641 (AAL, CSA)

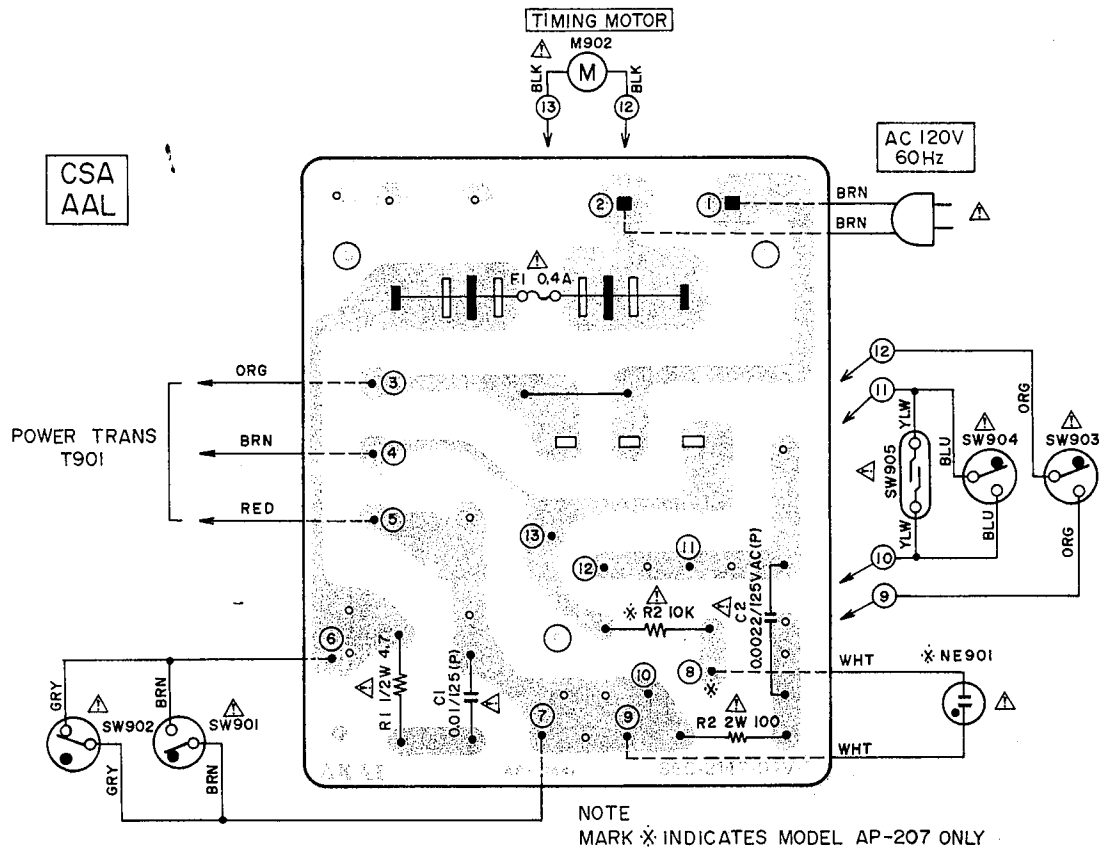

WARNING: Δ INDICATES SAFETY CRITICAL COMPONENTS. FOR CONTINUED SAFETY, REPLACE SAFETY CRITICAL COMPONENTS ONLY WITH MANUFACTURER'S RECOMMENDED PARTS.
 AVERTISSEMENT: Δ IL INDIQUÉ LES COMPOSANTS CRITIQUES DE SÛRETÉ. POUR MAINTENIR LE DEGRÉ DE SÛRETÉ DE L'APPAREIL, NE REMPLACER LES COMPOSANTS DONT LE FONCTIONNEMENT EST CRITIQUE POUR LA SÛRETÉ QUE PAR DES PIÈCES RECOMMANDÉES PAR LE FABRICANT.

5) POWER SUPPLY P.C BOARD AP-2641 (UK, CEE)

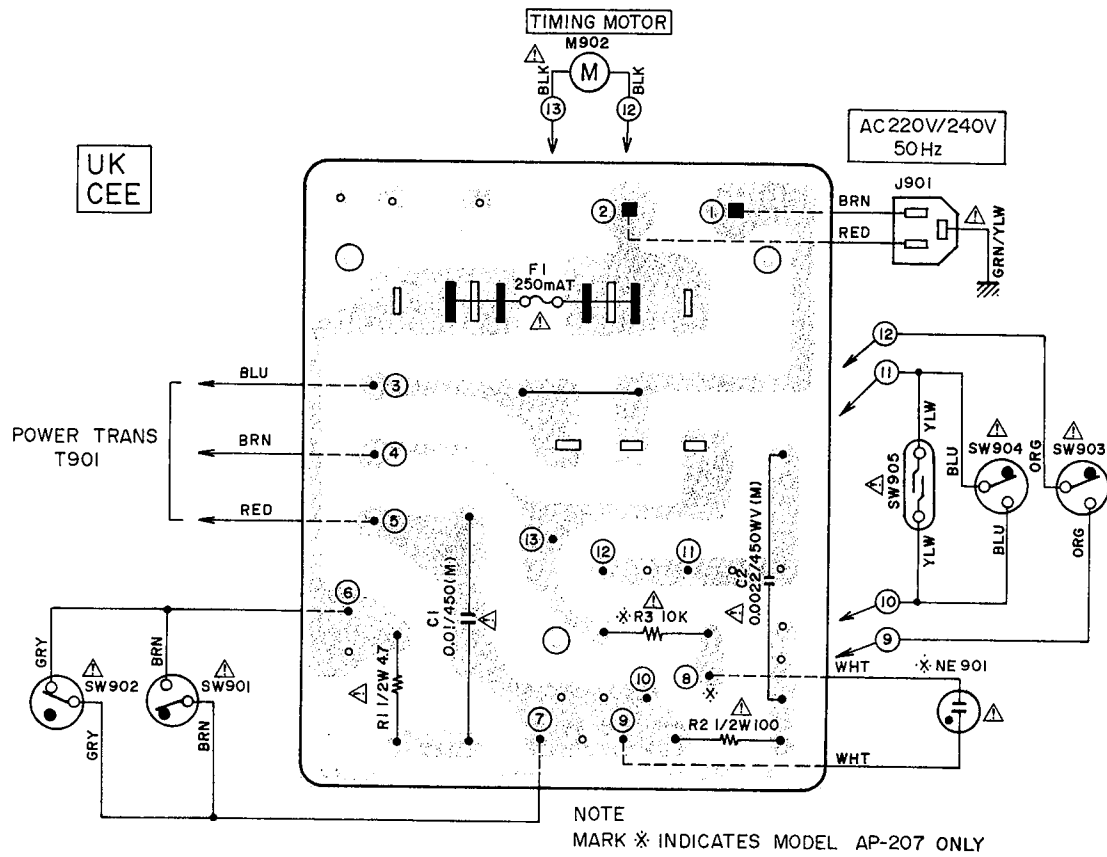

WARNING: Δ INDICATES SAFETY CRITICAL COMPONENTS. FOR CONTINUED SAFETY,
REPLACE SAFETY CRITICAL COMPONENTS ONLY WITH MANUFACTURER'S
RECOMMENDED PARTS

AVERTISSEMENT: Δ IL INDIQUE LES COMPOSANTS CRITIQUES DE SÛRETÉ. POUR
MAINTENIR LE DEGRÉ DE SÛRETÉ DE L'APPAREIL, NE REMPLACER LES
COMPOSANTS DONT LE FONCTIONNEMENT EST CRITIQUE POUR LA SÛRETÉ
QUE PAR DES PIÈCES RECOMMANDÉES PAR LE FABRICANT

MEMO

MEMO

MEMO

MEMO

SECTION 2

PARTS LIST

TABLE OF CONTENTS

1. D.D P.C BOARD (AP-2642) BLOCK	32
2. POWER SUPPLY P.C BOARD (AP-2641) BLOCK	32
3. PLL P.C BOARD (AP-3601) BLOCK (AP-307)	33
4. AP-207 ASSEMBLY BLOCK (1)	34
5. AP-207 ASSEMBLY BLOCK (2)	36
6. AP-207 ASSEMBLY BLOCK (3)	38
7. AP-307 ASSEMBLY BLOCK (1)	40
8. AP-307 ASSEMBLY BLOCK (2)	42
9. AP-307 ASSEMBLY BLOCK (3)	44
INDEX	46

Resistor and Capacitor which is not listed in this parts list, please refer to COMMON LIST FOR SERVICE PARTS.

HOW TO USE THIS PARTS LIST

1. This parts list is compiled by various individual blocks based on assembly process.
2. When ordering parts, please describe parts number, serial number, and model number in detail.
3. How to read List

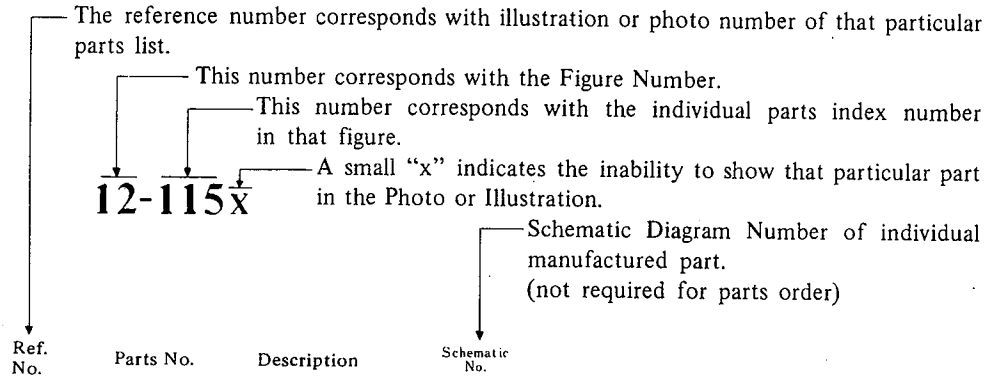

Ref. No.	Parts No.	Description	Schematic No.
FLYWHEEL BLOCK #13			
12-115x	800425	Flywheel Block Assy. Comp.	RDG #13
12-116	244506	Flywheel Only	RD-233
12-117x	244754	Felt, Flywheel	RD-275
12-118	251324	Main Metal Case	RD-236
12-119	253080	Main Metal	RD-237

4. The symbol numbers shown on the P.C. Board list can be matched with the Composite Views of Components of the Schematic Diagram or Service Manual.
5. Please utilize separate "Common List for Service Parts" for Resistor Parts orders.
6. The shape of the parts and parts name, etc. can be confirmed by comparing them with the parts shown on the Electrical Parts Table of P.C. Board.
7. Both the kind of part and installation position can be determined by the Parts Number. To determine where a parts number is listed, utilize Parts Index at end of Parts List.
It is necessary first of all to find the Parts Number. This can be accomplished by using the Reference Number listed at right of parts number in the Parts Index. (meaning of ref. no. outlined in Item 3 above).
8. Utilize separate "Price List for Parts" to determine unit price. The most simple method of finding parts Price is to utilize the reference number.

- CAUTION:**
1. When placing an order for parts, be sure to list the parts no. model no., and description. There are instances in which if any of this information is omitted, parts cannot be shipped or the wrong parts will be delivered.
 2. Please be careful not to make a mistake in the parts no. If the parts no. is in error, a part different from the one ordered may be delivered.
 3. Because parts number and parts unit supply in the Preliminary Service Manual (Basic Parts List) may be partially changed, please use this parts list for all future reference.

WARNING: **⚠** INDICATES SAFETY CRITICAL COMPONENTS. FOR CONTINUED SAFETY, REPLACE SAFETY CRITICAL COMPONENTS ONLY WITH MANUFACTURER'S RECOMMENDED PARTS.

AVERTISSEMENT: **⚠** IL INDIQU LES COMPOSANTS CRITIQUES DE SURETE. POUR MAINTENIR LE DEGRE DE SECURITE DE L'APPAREIL NE REMPLACER LES COMPOSANTS DONT LE FONCTIONNEMENT EST CRITIQUE POUR LA SECURITE QUE PAR DES PIECES RECOMMANDEES PAR LE FABRICANT.

AC INLET SYSTEM

This model is equipped with an AC INLET SYSTEM. Please refer to the AC INLET SYSTEM CHART below for the specific type. By the AC INLET SYSTEM, AC (mains) cord can be connected to and disconnected from the model because the model is provided with socket exclusively for AC (mains) cord on its main body. Please note, however, that certain models are not equipped with this system and has a built-in AC (mains) cord as before.

AC INLET SYSTEM CHART

CLASS I

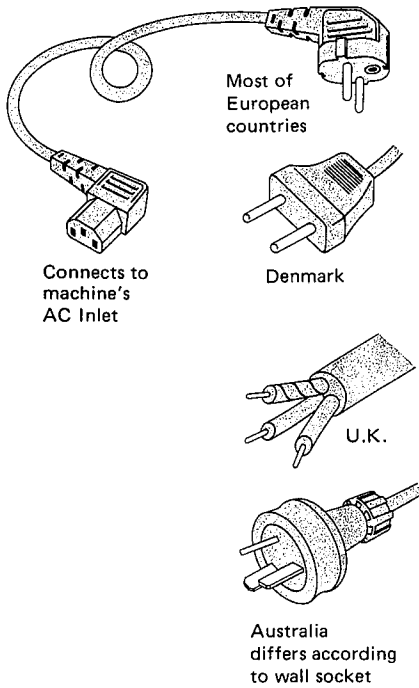
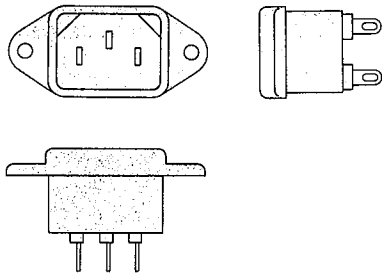

Picture 1
AC INLET
to be
installed
on machines

CLASS II

☐ This mark indicating double insulation will be attached to machine's rear panel

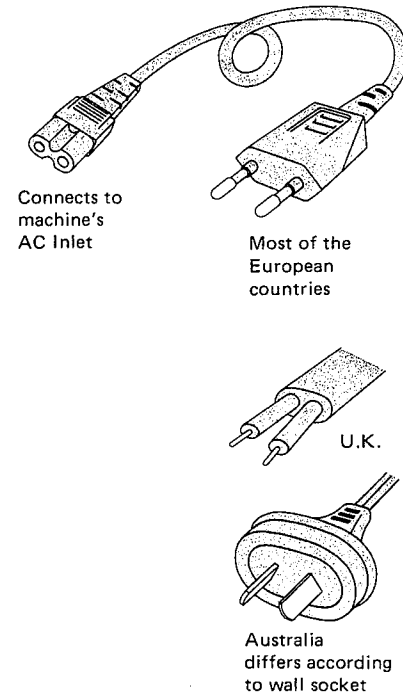
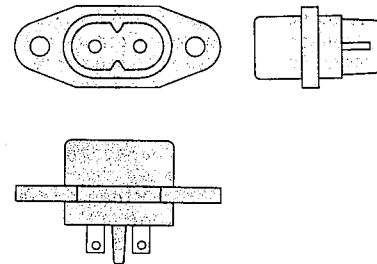

Picture 2
AC (mains)
cord

Parts List for AC (mains) Cord Set

	Standard	Description	Type of AC Inlet	Parts No.
Class I	CEE	Cord Set CEE (3 cores)	3P	EW302993
	BEAB	Cord Set BEAB (3 cores)	3P	EW302994
	SAA	Cord Set SAA (3 cores)	3P	EW302996
	U/T	Cord Set U/T (3 cores)	3P	EW302646
Class II	CEE	Cord Set CEE (2 cores)	2P	EW638144
	BEAB	Cord Set BEAB (2 cores)	2P	EW302995
	SAA	Cord Set SAA (2 cores)	2P	EW302991
	U/T	Cord Set U/T (2 cores)	2P	EW302899

1. D.D P.C BOARD (AP-2642) BLOCK

Symbol No.	Parts No.	Description	Schematic No.
1-1	BA307042	D.D P.C Board Comp. AP-206 (U/T) (207/307-U/T, CSA, AAL)	
1-2	BA307043	D.D P.C Board Comp. AP-206 (CEE) (207/307-CEE, UK)	
1-IC1	EI306703	IC TA75458P	45-8-309
1-IC2	EI306704	IC TC4030BP	45-8-264
1-IC3	EI304657	IC TC4011BP	45-8-232
1-IC4	EI306703	IC TA75458P	45-8-309
1-TR1	ET306705	Transistor 2SC1815 (O) (Y)	45-1-299
1-TR2	ET306719	Transistor 2SC2236 (O) (Y)	45-1-307
1-TR3	ET306720	Transistor 2SA966 (O) (Y)	45-1-306
1-TR4	ET306719	Transistor 2SC2236 (O) (Y)	45-1-307
1-TR5	ET306720	Transistor 2SA966 (O) (Y)	45-1-306
1-TR6	ET306721	Transistor 2SC790 (O) (Y)	45-1-304
1-TR7	ET633677	Transistor 2SA490 (O) (Y)	45-1-213
1-D1,2	ED557447	Silicon Diode 1S1588	45-3-22
1-D3,4	ED306722	Zener Diode 05Z-7.5U	45-6-76
1-D5,6	ED306723	Zener Diode 05Z-10U	45-6-76
1-D7to10	ED306724	Silicon Diode S5277B	45-2-79
1-VR1	EV269572	Semi-fixed/Vol. V10K8-4-2 2 kB	36-10-250
1-VR2,3	EV648527	Semi-fixed/Vol. V10K8-4-2 200 kB	36-10-250
1-VR4,5	EV560136	Semi-fixed/Vol. V10K8-4-2 20 kB	36-10-250
1-VR6	EV499882	Semi-fixed/Vol. V10K8-4-2 300 kB	36-10-250
1-C10	EC306788	Solid Aluminum/C. (Vert. Type) 2.2 μ F(M) 16WV	24-19-2
1-C11	EC215065	Solid Aluminum/C. (Vert.Type) 0.47 μ F(M) 16WV	24-19-2

2. POWER SUPPLY P.C BOARD (AP-2641) BLOCK

Symbol No.	Parts No.	Description	Schematic No.
2-SW1	ES306725	Δ Slide SW. J-S4017 (U/T)	25-3-157
2-C1,2	EC551160	Δ Ceramic/C. DB821 NA 0.01 μ F(Z) 1.4kV (U/T)	24-5-55
2-C1	EC294118	Δ Ceramic/C. DPN6600 YM 0.01 μ F(P) 125WV (CSA, AAL)	24-5-70
2-C1	EC306477	Δ Oil Paper/C. ECN-C4A 0.01 μ F(M) 450WV (CEE, UK)	24-8-6
2-C2	EC303211	Δ Ceramic/C. DP6410 YZ 0.0022 μ F(P) 125VAC (CSA, AAL)	24-5-73
2-C2	EC308508	Δ Oil Paper/C. 0.0022 μ F(M) 450WV (CEE, UK)	24-8-6

3. PLL P.C BOARD (AP-3601) BLOCK (AP-307)

Symbol No.	Parts No.	Description	Schematic No.
3-1	BA307047	PLL P.C Board Comp. AP-306 (U/T) (307-U/T, CSA, AAL)	
3-2	BA307048	PLL P.C Board Comp. AP-306 (CEE) (307-CEE, UK)	
3-IC1	EI306726	IC TC4069BP	45-8-263
3-IC2	EI306727	IC TC4013BP	45-8-265
3-IC3	EI306728	IC TC5080P	45-8-307
3-IC4	EI306729	IC TC4040BP	45-8-266
3-IC5	EI306730	IC TC5081P	45-8-308
3-IC6	EI306757	IC TC4002BP	45-8-272
3-TR1	ET306731	Transistor 2SC2229 (O)	45-1-305
3-D1,2	ED306732	Silicon Diode S5277D	45-2-80
3-X1	EI306756	Crystal OSC 4.42368MHz	53-1-129
3-VR1	EV306737	Semi-fixed/Vol. V10K8-1-2 50 kB	36-10-255
3-VC1	EC616342	Trimmer/C. CTY-15D33 15PF	24-2-32

4. ILLUSTRATION OF AP-207 ASSEMBLY BLOCK (1)

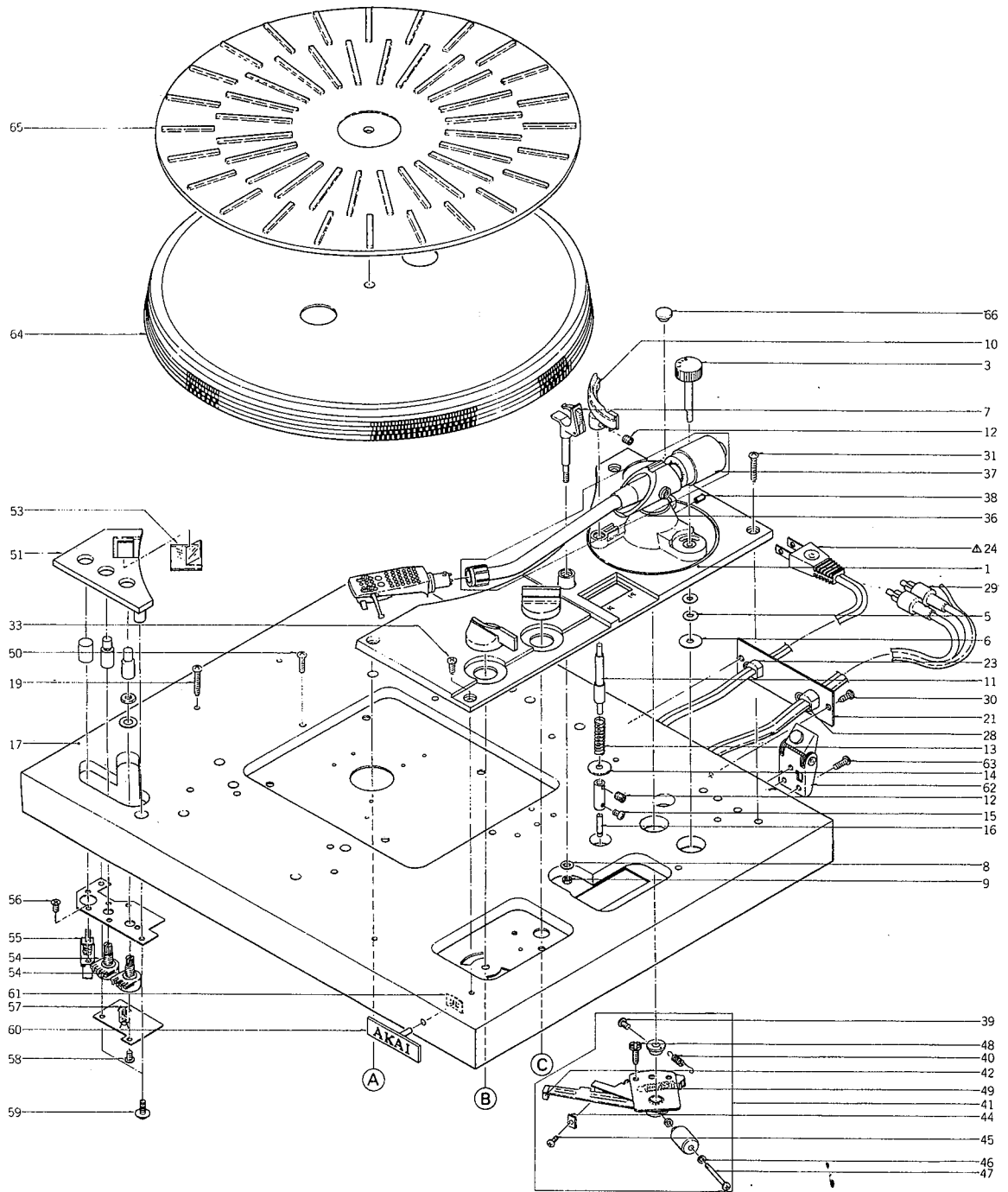

4) AP-207 ASSEMBLY BLOCK (1)

Ref. No.	Parts No.	Description	Schematic No.	Ref. No.	Parts No.	Description	Schematic No.
ARM STAND BLOCK				4-61	ZW575730	Speed Nut (P Type) (3)	6-3-6
4-1	TP308504	Arm Stand (A)	AP-2606,2648	4-62	TP302921	Hinge (A)	9-4-4
4-2x	TP308505	Arm Stand (A-BL)	AP-2606,2648	4-63	ZS297088	Tapping Screw #1, 3x10 (Pan) (Black)	
4-3	SK302831	Canceller Knob AP	AP-0093	4-64	TP306762	Platter	1-34-2
4-4x	SK305808	Canceller Knob (BL) AP	AP-0093	4-65	TP302754	Table Sheet	AP-0002
4-5	ZW304694	'O' Ring 5x8	3-12-8	4-66	TP302504	Rubber Bush	AP-0043
4-6	ZW302781	Push Nut D5					
4-7	TP302769	Arm Rest Comp. AP	AP-0092				
4-8	ZW273802	Toothed Lock Washer, M3					
4-9	ZW516993	Nut M3, #1					
4-10	TP306510	Elevation	AP-2613				
4-11	TP306511	Elevation Shaft	AP-2614				
4-12	ZS310539	Set Screw, hexagon socket 2.6x4 (Cone/P.)					
4-13	ZG306657	Lifter Spring	AP-2639				
4-14	ZW307341	Washer D3.5x15x0.8t	AP-2758				
4-15	ZS608220	Screw, pan head 2.6x6					
4-16	TP307285	Elevation Shaft	AP-2707				
ASSEMBLY BLOCK							
4-17	BC306490	Cabinet (A)	AP-2603				
4-18x	BC306492	Cabinet (A-BL)	AP-2603				
4-19	ZS312530	Tapping Screw #2, 3x15 (BR) (Black)					
4-20x	ZS558090	Screw, binding head 4x14 (Black)					
4-21	TP302861	Terminal Plate (B) (U/T, CSA, AAL)	AP-0022				
4-22x	TP302864	Terminal Plate (A) (CEE, UK)	AP-0031				
4-23	EZ631945	Strain Relief SR-4N-4 (U/T, CSA, AAL)	2-7-49				
4-24	EW306428	Δ AC Cord (U/T)	26-3-64				
4-25x	EW305691	Δ AC Cord CUL (CSA, AAL)	26-3-65				
4-26x	EJ296853	Δ 3P In-Let CM-3 (CEE, UK)	31-1-199				
4-27x	ZS447840	Tapping Screw #2, 3x8 (BR) (CEE, UK)					
4-28	EZ304430	Strain Relief 5K-4	2-7-63				
4-29	EW302795	2P Audio Cord 1.25M	26-8-12				
4-30	ZS297088	Tapping Screw #1, 3x10 (Pan) (Black)					
4-31	ZS346015	Screw, binding head 3x25					
4-32x	ZS535825	Screw, binding head 3x25(Black)					
4-33	ZS308513	Tapping Screw #2, 3x12 (BR) W=8					
4-34x	ZS309098	Tapping Screw #1, 3x15 (Bind)					
4-35x	ZS309099	Tapping Screw #1, 3x15 (Bind) (Black)					
4-36	TP304895	Tone Arm Block Comp. AP-206	53-1-142				
4-37	TP308511	Main Weight ARM-206	53-1-142				
4-38	ZS306485	Set Screw, hexagon socket 4x6 (CUP./P.)					
4-39	ZS590804	Screw, pan head 2.3x6					
4-40	ZG302825	Coil Spring (4)	AP-0021				
4-41	TP307110	PU Plate Assy AP-207					
4-42	TP302925	Ferrite Magnet	5-1-19				
4-43x	MH302480	Lock Pin	AP-0118				
4-44	TP307298	Magnet	AP-2720				
4-45	ZS592378	Screw, pan head 2.6x3					
4-46	ZW273914	Spring Washer, M4					
4-47	ZS421086	Screw, pan head 4x30					
4-48	ZS305246	Adjust Screw (B)	AP-00117				
4-49	ZG516418	Eject Spring	CG-1238				
4-50	ZS421806	Screw, pan head 3x8					
4-51	TP306502	Vol. Stand (A)	AP-2610,2646				
4-52x	TP306504	Vol. Stand (A-BL)	AP-2610,2646				
4-53	TP306509	Prism	AP-2612				
4-54	EV306759	Vol. VM10A 20 kB	36-6-33				
4-55	ES305681	Push SW. SUE12	25-5-279				
4-56	ZS200384	Screw, countersunk head 3x6					
4-57	EL306690	Neon Lamp NE-2HH	28-3-9				
4-58	ZS325495	Tapping Screw #2, 3x6 (BR)					
4-59	ZS308513	Tapping Screw #2, 3x12 (BR) W=8					
4-60	SM302824	Name Plate AP	AP-0086				

5. ILLUSTRATION OF AP-207 ASSEMBLY BLOCK (2)

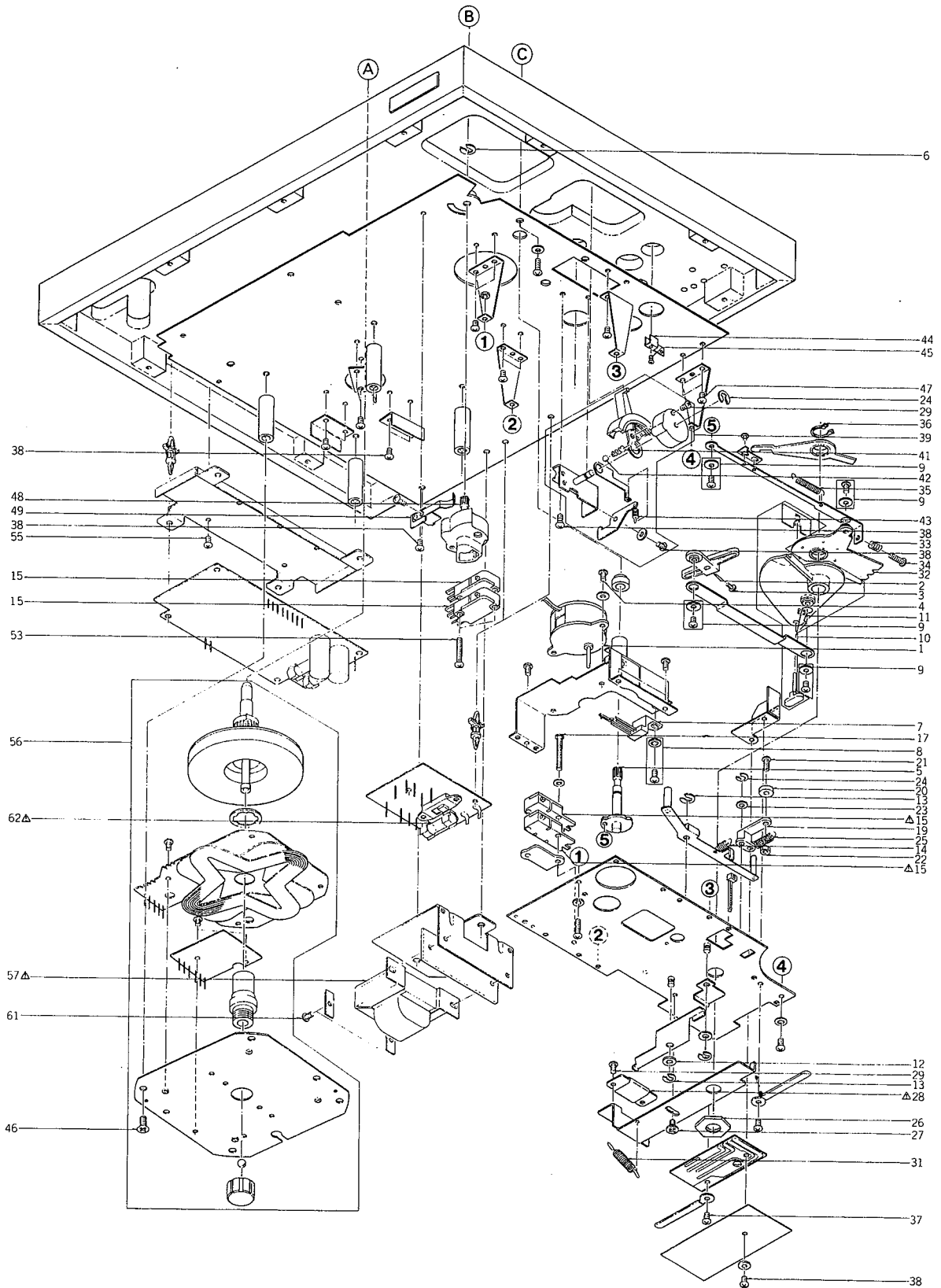

5) AP-207 ASSEMBLY BLOCK (2)

Ref. No.	Parts No.	Description	Schematic No.	Ref. No.	Parts No.	Description	Schematic No.
AUTO MECHA BLOCK							
5-1	BM307345	Motor Block Comp. D115F52-12	9-2-19	5-59x	BT306694	△ Power Trans. APT2-40 (CEE)	38-4-655
5-2	TP307311	Drive Arm	AP-2736	5-60x	BT306695	△ Power Trans. APT2-50 (UK)	38-4-656
5-3	ZS575392	Screw, pan head 2.6x8		5-61	ZS413234	Screw, pan head 4x12	
5-4	ZS558101	Screw, pan head 3x6 w/washer		5-62	EF214727	△ Fuse SS-2 0.5A 250V (U/T)	39-1-56
5-5	TP307310	Selector Cam	AP-2735	5-63x	EF659507	△ Fuse SS-2 1A 250V (U/T)	39-1-56
5-6	ZW270123	'E' Ring 4M	6-1-9	5-64x	EF306702	△ Fuse ST-6 0.4A (CSA, AAL)	39-1-63
5-7	ES308509	Leaf SW. MSW-0097	25-10-36	5-65x	EF300586	△ Fuse (EAWK) 250MAT (CEE, UK)	39-1-60
5-8	ZS265814	Screw, pan head 3x5 W=8		5-66x	EF300589	△ Fuse (EAWK) 315MAT (CEE, UK)	39-1-60
5-9	ZS608321	Screw, pan head 3x6 W=8					
5-10	TP308005	Operation Plate Part AP-207	AP-2745				
5-11	ZG307321	Inversion Spring	AP-2746				
5-12	ZW450753	Washer (Nylon) D4.2x9x1t					
5-13	ZW290283	'U' Ring 2.85M	6-1-1				
5-14	ZG385413	Auto Stop Spring (B)	CS-1033				
5-15	ES573456	△ Micro SW. K-2 (U/T, CSA, AAL)	25-1-30				
5-16x	ES302772	△ Micro SW. V1A-445 (CEE, UK)	25-1-44				
5-17	ZS608354	Screw, pan head 3x30 (U/T, CSA, AAL)					
5-18x	ZS307346	Screw, pan head 3x30 (CEE, UK)					
5-19	TP307306	Click Lever	AP-2730				
5-20	ZW310459	Click Lever Washer (1)	AP-2781				
5-21	ZS391408	Screw, pan head 2.3x12					
5-22	ZW273690	Nut #1, M2.3					
5-23	ZW420682	Washer (Nylon) D4.2x9x0.5t					
5-24	ZW482635	'U' Ring 3M	6-1-1				
5-25	ZG542215	Spring (B)	CZ-1011				
5-26	ZW307314	Arm Washer	AP-2739				
5-27	ZS469710	MR Graduated Screw	MR-254				
5-28	ES516036	△ Reed SW. ORD-225	25-11-1				
5-29	ZS379350	Screw, pan head 3x6 (U/T, CSA, AAL)					
5-30x	ZS522922	Screw, pan head 3x6 (PC) (CEE, UK)					
5-31	ZG307316	Return Spring	AP-2740				
5-32	TP307323	Selector Lever	AP-2748				
5-33	ZG580533	Clamp Spring	TD-2046				
5-34	ZS305246	Adjust Screw (B)	AP-00117				
5-35	ZG567685	Azimuth Spring (1)	CP-0040				
5-36	ZW307294	'C' Ring STW-10-C-3	6-1-3				
5-37	ZS447840	Tapping Screw #2, 3x8 (BR)					
5-38	ZS325495	Tapping Screw #2, 3x6 (BR)					
HAND LIFTER BLOCK							
5-39	TP307437	Hand Lifter Block Comp. AP-207					
5-40x	TP307438	Hand Lifter Block Comp. AP-207-BL					
5-41	ZG307331	Spring, ball holder	AP-2756				
5-42	MV269965	Steel Ball D4					
5-43	ZG317496	Felt Tension Spring	MR-260				
ASSEMBLY BLOCK							
5-44	TP306519	Canceller Lever	AP-2623				
5-45	ZS460440	Screw, pan head 2x4					
5-46	ZS414044	Screw, countersunk head 4x8					
5-47	ZS406416	Tapping Screw #2, 3x8 (countersunk)					
5-48	TP307281	Start Cam	AP-2703				
5-49	ZG307280	Start Spring	AP-2702				
5-50x	ZW273892	Toothed Lock Washer, M4 (CEE, UK)					
5-51x	ZS417150	Screw, pan head 4x6 (CEE, UK)					
5-52x	ZW413188	Nut M4, #1 (CEE, UK)					
5-53	ZS608264	Screw, pan head 3x25 (U/T, CSA, AAL)					
5-54x	ZS306486	Tapping Screw #2, 3x8 (BR) w/washer					
5-55	ZS308510	Tapping Screw #1, 3x10 (Pan) (Black)					
5-56	BM307307	Motor DDM-33D	9-2-25				
5-57	BT306692	△ Power Trans. APT2-70 (U/T)	38-4-657				
5-58x	BT306693	△ Power Trans. APT2-20 (CSA, AAL)	38-4-654				

6. PHOTO OF AP-207 ASSEMBLY BLOCK (3)



6) AP-207 ASSEMBLY BLOCK (3)

Ref. No.	Parts No.	Description	Schematic No.
6-1	SP306494	Bottom Cover (A) (Black)	AP-2604
6-2	SA306656	Insulator	AP-2637
6-3x	MH306736	Spacer 3x4	7-2-6
6-4x	ZW306761	Washer D3.1x12x1t (Black)	
6-5x	ZS522865	Tapping Screw #2, 3x12 (BR) (Black)	
6-6x	ZS308506	Tapping Screw #1, 3x15 (Truss) (Black)	
6-7	SK307329	Selector Knob	AP-2755
6-8x	SK307330	Selector Knob (BL)	AP-2755
6-9	SK306498	Knob (A)	AP-2608
6-10x	SK306499	Knob (A-BL)	AP-2608
6-11	SK306500	Knob(B)	AP-2609
6-12x	SK306501	Knob (B-BL)	AP-2609
6-13	SK300102	Push Button Knob(L) Part CM-2	91-5051
6-14x	SK305457	Push Button Knob(P) Part CM-2BL	91-5051
6-15	BC307073	Dust Cover Comp. AP-206	AP-2601
6-16	TP302926	Hinge (B)	9-4-5
6-17	ZS301580	Screw, oval countersunk head 4x8	
6-18	TP301300	Cover Cushion	AC-3842
6-19x	ZS306799	Screw, pan head 3x14 (Black) (AAL)	
6-20x	ZW516611	Nut M3 (AAL)	

When ordering parts, please describe Parts Number, Description, and Model Number in detail.

7. ILLUSTRATION OF AP-307 ASSEMBLY BLOCK (1)

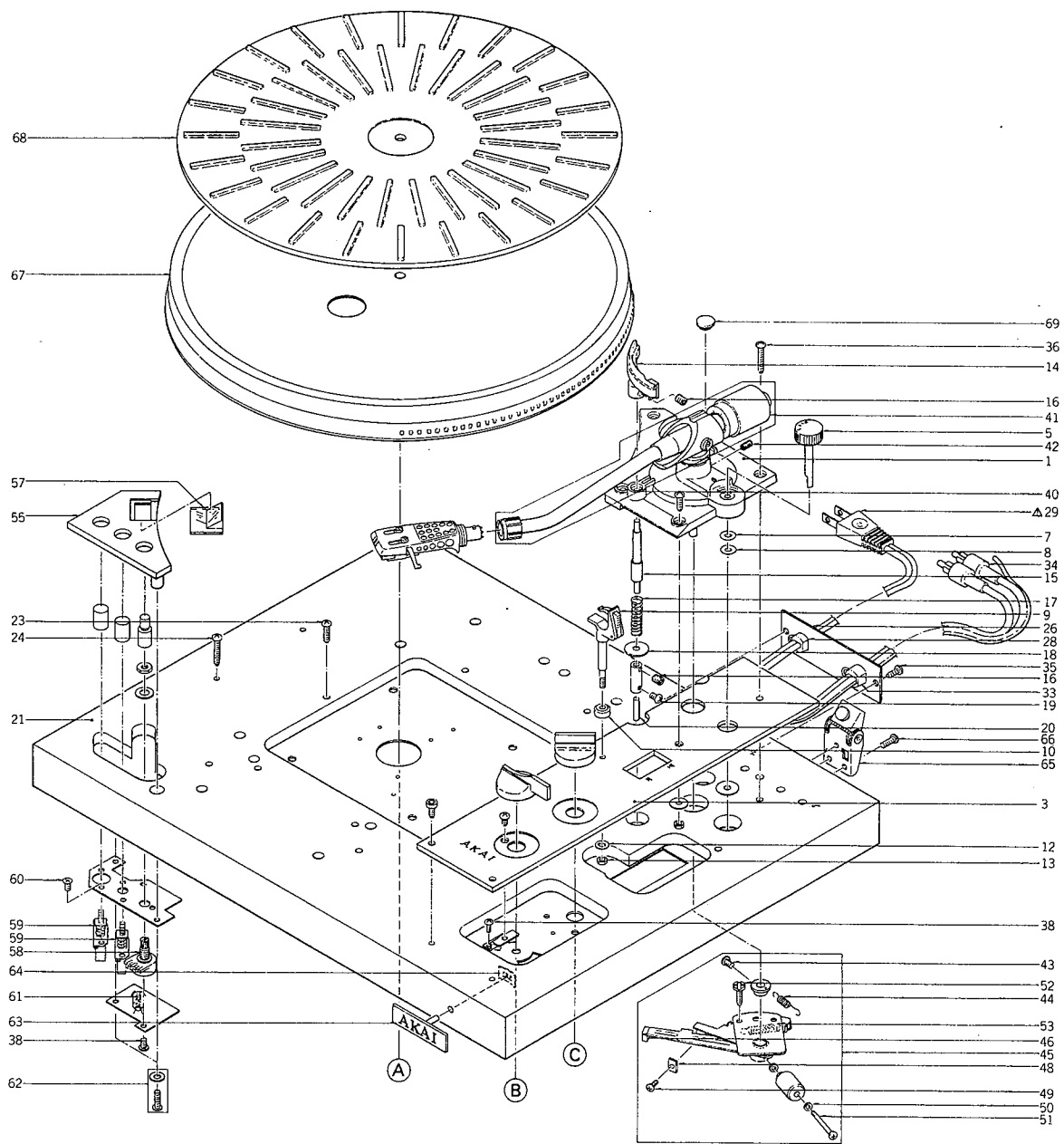

7) AP-307 ASSEMBLY BLOCK (1)

Ref. No.	Parts No.	Description	Schematic No.	Ref. No.	Parts No.	Description	Schematic No.
ARM STAND BLOCK				7-64	ZW575730	Speed Nut (P Type) (3)	6-3-6
7-1	TP306680	Arm Stand	AP-3606	7-65	TP302921	Hinge (A)	9-4-4
7-2x	TP306681	Arm Stand (BL)	AP-3606	7-66	ZS297088	Tapping Screw #1, 3x10 (Pan) (Black)	
7-3	SP307347	Panel (A)	AP-3605,3608	7-67	TP306716	Platter	1-34-3
7-4x	SP307348	Panel (A-BL)	AP-3605,3608	7-68	TP302754	Table Sheet	AP-0002
7-5	SK302831	Cancellor Knob AP	AP-0093	7-69	TP302504	Rubber Bush	AP-0043
7-6x	SK305808	Cancellor Knob (BL) AP	AP-0093				
7-7	ZW304694	'O' Ring 5x8	3-12-8				
7-8	ZW302781	Push Nut D5					
7-9	TP302769	Arm Rest Comp. AP	AP-0092				
7-10	TP306672	Arm Rest Stand	AP-3604				
7-11x	TP306673	Arm Rest Stand (BL)	AP-3604				
7-12	ZW273802	Toothed Lock Washer, M3					
7-13	ZW516993	Nut M3, #1					
7-14	TP306510	Elevation	AP-2613				
7-15	TP306511	Elevation Shaft	AP-2614				
7-16	ZS310539	Set Screw, hexagon socket 2.6x4 (CONE/P.)					
7-17	ZG306657	Lifter Spring	AP-2639				
7-18	ZW307341	Washer D3.5x15x0.8t	AP-2758				
7-19	ZS608220	Screw, pan head 2.6x6					
7-20	TP307285	Elevation Shaft	AP-2707				
ASSEMBLY BLOCK							
7-21	BC306491	Cabinet (B)	AP-2603				
7-22x	BC306493	Cabinet (B-BL)	AP-2603				
7-23	ZS305254	Tapping Screw #1, 3x8 (Pan)					
7-24	ZS312530	Tapping Screw #2, 3x15 (BR) (Black)					
7-25x	ZS558090	Screw, binding head 4x14					
7-26	TP302861	Terminal Plate (B) (U/T, CSA, AAL)	AP-0022				
7-27x	TP302864	Terminal Plate (A) (CEE, UK)	AP-0031				
7-28	EZ631945	Strain Relief SR-4N-4 (U/T, CSA, AAL)	2-7-49				
7-29	EW306428	Δ AC Cord (U/T)	26-3-64				
7-30x	EW305691	Δ AC Cord CUL (CSA, AAL)	26-3-65				
7-31x	EJ296853	Δ 3P In-Let CM-3 (CEE, UK)	31-1-199				
7-32x	ZS447840	Tapping Screw #2, 3x8 (BR) (CEE, UK)					
7-33	EZ304430	Strain Relief 5K-4	2-7-63				
7-34	EW302795	2P Audio Cord 1.25M	26-8-12				
7-35	ZS297088	Tapping Screw #1, 3x10 (Pan) (Black)					
7-36	ZS346015	Screw, binding head 3x25					
7-37x	ZS535825	Screw, binding head 3x25					
7-38	ZS325495	Tapping Screw #2, 3x6 (BR)					
7-39x	ZS414033	Screw, countersunk head 3x8					
7-40	TP304895	Tone Arm Block Comp. AP-206	53-1-142				
7-41	TP308511	Main Weight ARM-206	53-1-142				
7-42	ZS306485	Set Screw, hexagon socket 4x6 (CUP./P.)					
7-43	ZS590804	Screw, pan head 2.3x6					
7-44	ZG302825	Coil Spring (4)	AP-0021				
7-45	TP307110	PU Plate Assy AP-207					
7-46	TP302925	Ferrite Magnet	5-1-19				
7-47x	MH302480	Lock Pin	AP-0118				
7-48	TP307298	Magnet	AP-2720				
7-49	ZS592378	Screw, pan head 2.6x3					
7-50	ZW273914	Spring Washer, M4					
7-51	ZS421086	Screw, pan head 4x30					
7-52	ZS305246	Adjust Screw (B)	AP-00117				
7-53	ZG516418	Eject Spring	CG-1238				
7-54x	ZS421806	Screw, pan head 3x8					
7-55	TP306503	Vol. Stand (B)	AP-2610,2646				
7-56x	TP306506	Vol. Stand (B-BL)	AP-2610,2646				
7-57	TP306509	Prism	AP-2612				
7-58	EV306759	Vol. VM10A 20 kB	36-6-33				
7-59	ES305681	Push SW. SUE12	25-5-279				
7-60	ZS200384	Screw, countersunk head 3x6					
7-61	EL306690	Neon Lamp NE-2HH	28-3-9				
7-62	ZS308513	Tapping Screw #2, 3x12 (BR) W=8					
7-63	SM302824	Name Plate AP	AP-0086				

When ordering parts, please describe Parts Number, Description, and Model Number in detail.

8. ILLUSTRATION OF AP-307 ASSEMBLY BLOCK (2)

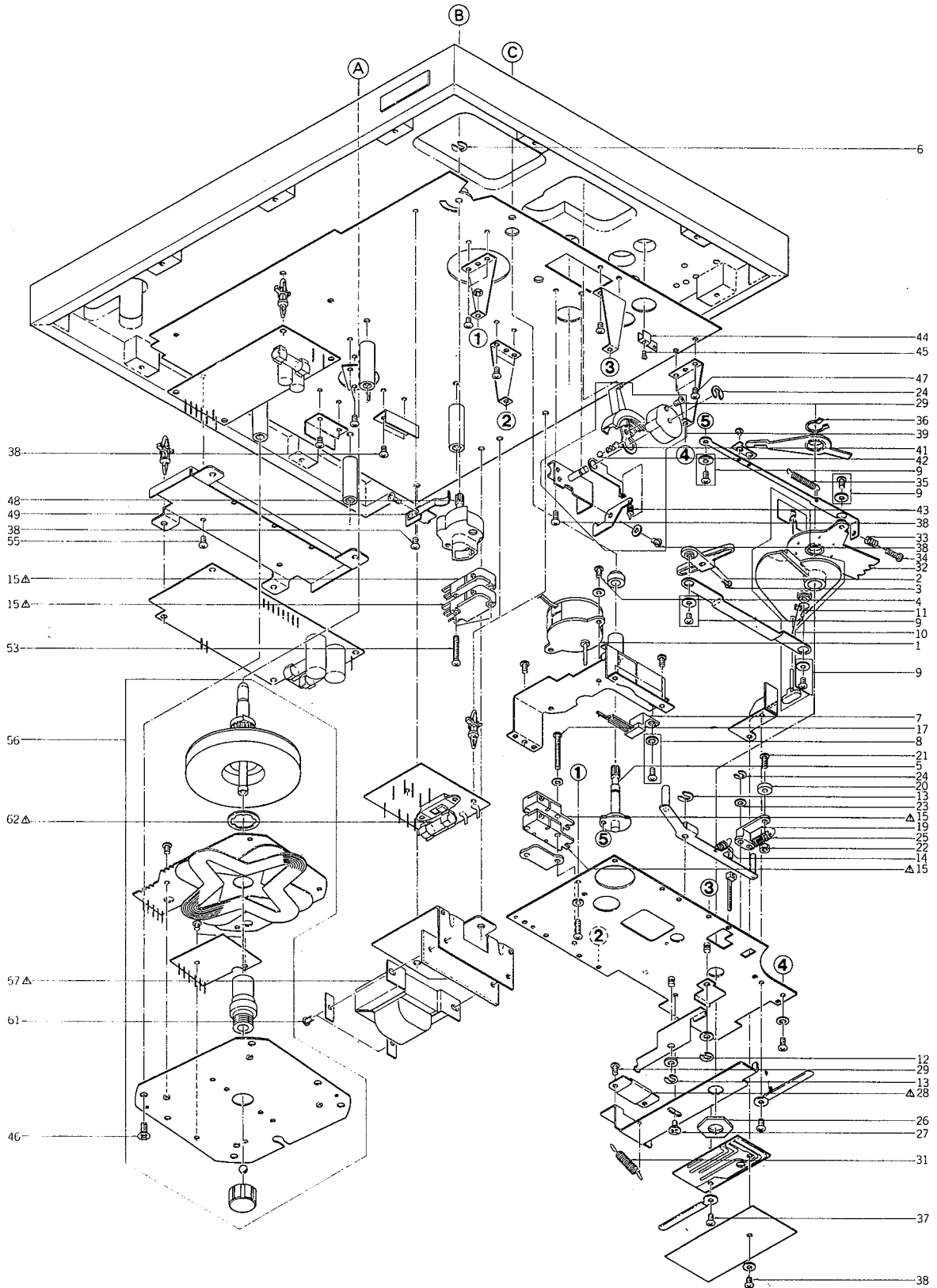

8) AP-307 ASSEMBLY BLOCK (2)

Ref. No.	Parts No.	Description	Schematic No.	Ref. No.	Parts No.	Description	Schematic No.
AUTO MECHA BLOCK							
8-1	BM307345	Motor Block Comp. D115F52-12	9-2-19	8-58x	BT306697	△ Power Trans. APT1-20 (CSA, AAL)	38-4-609
8-2	TP307311	Drive Arm	AP-2736	8-59x	BT306698	△ Power Trans. APT1-40 (CEE)	38-4-607
8-3	ZS575392	Screw, pan head 2.6x8		8-60x	BT306699	△ Power Trans. APT1-50 (UK)	38-4-610
8-4	ZS558101	Screw, pan head 3x6 w/washer		8-61	ZS413234	Screw, pan head 4x12	
8-5	TP307310	Selector Cam	AP-2735	8-62	EF214727	△ Fuse SS-2 0.5A 250V (U/T)	39-1-56
8-6	ZW270123	'E' Ring M	6-1-9	8-63x	EF306702	△ Fuse ST-6 0.4A (CSA, AAL)	39-1-63
8-7	ES308509	Leaf SW. MSW-0097	25-10-36	8-64x	EF300586	△ Fuse (EAWK) 250MAT (CEE, UK)	39-1-60
8-8	ZS265814	Screw, pan head 3x5 W=8		8-65x	EF659507	△ Fuse SS-2 1A 250V (U/T)	39-1-56
8-9	ZS608321	Screw, pan head 3x6 W=8		8-66x	EF300589	△ Fuse (EAWK) 315MAT (CEE, UK)	39-1-60
8-10	TP308005	Operation Plate Part AP-207	AP-2745	8-67x	EF306700	△ Fuse SS-2 0.1A 250V (U/T)	39-1-56
8-11	ZG307321	Inversion Spring	AP-2746	8-68x	EF486134	△ Fuse ULMF61ML 125V 0.1A (CSA, AAL)	39-1-40
8-12	ZW450753	Washer (Nylon) D4.2x9x1t		8-69x	EF300575	△ Fuse (EAWK) 100MAT (CEE, UK)	39-1-60
8-13	ZW290283	'U' Ring 2.85M	6-1-1				
8-14	ZG385413	Auto Stop Spring (B)	CS-1033				
8-15	ES573456	△ Micro SW. K-2 (U/T, CSA, AAL)	25-1-30				
8-16x	ES302772	△ Micro SW. V1A-445 (CEE, UK)	25-1-44				
8-17	ZS608354	Screw, pan head 3x30 (U/T, CSA, AAL)					
8-18x	ZS307346	Screw, pan head 3x30(CEE, UK)					
8-19	TP307306	Click Lever	AP-2730				
8-20	ZW310459	Click Lever Washer (1)	AP-2781				
8-21	ZS391408	Screw, pan head 2.3x12					
8-22	ZW273690	Nut #1, M2.3					
8-23	ZW420682	Washer (Nylon) D4.2x9x0.5t					
8-24	ZW482635	'U' Ring 3M	6-1-1				
8-25	ZG542215	Spring (B)	CZ-1011				
8-26	ZW307314	Arm Washer	AP-2739				
8-27	ZS469710	MR Graduated Screw	MR-254				
8-28	ES516036	△ Reed SW. ORD-225	25-11-1				
8-29	ZS379350	Screw, pan head 3x6 (U/T, CSA, ALL)					
8-30x	ZS522922	Screw, pan head 3x6 (PC) (CEE, UK)					
8-31	ZG307316	Return Spring	AP-2740				
8-32	TP307323	Selector Lever	AP-2748				
8-33	ZG580533	Clamp Spring	TD-2046				
8-34	ZS305246	Adjust Screw (B)	AP-00117				
8-35	ZG567685	Azimuth Spring (1)	CP-0040				
8-36	ZW307294	'C' Ring STW-10-C-3	6-1-3				
8-37	ZS447840	Tapping Screw #2, 3x8 (BR)					
8-38	ZS325495	Tapping Screw #2, 3x6 (BR)					
HAND LIFTER BLOCK							
8-39	TP307437	Hand Lifter Block Comp. AP-207 (307)					
8-40x	TP307438	Hand Lifter Block Comp. AP-207-BL (307-BL)					
8-41	ZG307331	Spring, ball holder	AP-2756				
8-42	MV269965	Steel Ball D4					
8-43	ZG317496	Felt Tension Spring	MR-260				
ASSEMBLY BLOCK							
8-44	TP306519	Canceller Lever	AP-2623				
8-45	ZS460440	Screw, pan head 2x4					
8-46	ZS414044	Screw, countersunk head 4x8					
8-47	ZS406416	Tapping Screw #2, 3x8 (countersunk)					
8-48	TP307281	Start Cam	AP-2703				
8-49	ZG307280	Start Spring	AP-2702				
8-50x	ZW273892	Toothed Lock Washer, M4 (CEE, UK)					
8-51x	ZS417150	Screw, pan head 4x6					
8-52x	ZW413188	Nut M4, #1 (CEE, UK)					
8-53	ZS608246	Screw, pan head 3x25 (U/T, CSA, AAL)					
8-54x	ZS306486	Tapping Screw #2, 3x8 (BR) w/washer					
8-55	ZW308510	Tapping Screw #1, 3x10 (Pan) (Black)					
8-56	BM307307	Motor DDM-33D	9-2-25				
8-57	BT306696	△ Power Trans. APT1-70 (U/T)	38-4-608				

When ordering parts, please describe Parts Number, Description, and Model Number in detail.

9. PHOTO OF AP-307 ASSEMBLY BLOCK (3)



9) AP-307 ASSEMBLY BLOCK (3)

Ref. No.	Parts No.	Description	Schematic No.
9-1	SP306495	Bottom Cover (B)	AP-2604
9-2x	SP306494	Bottom Cover (A) (BL)	AP-2604
9-3	SA306656	Insulator	AP-2637
9-4	TP306669	Insulator Cap	AP-3602
9-5x	TP306670	Insulator Cap (BL)	AP-3602
9-6x	MH306736	Spacer 3x4	7-2-6
9-7x	ZW306761	Washer D3.1x12x1t (Black)	
9-8x	ZS522865	Tapping Screw #2, 3x12(BR) (Black)	
9-9x	ZS308506	Tapping Screw #1, 3x15 (Truss) (Black)	
9-10	SK307329	Selector Knob	AP-2755
9-11x	SK307330	Selector Knob (BL)	AP-2755
9-12	SK306498	Knob (A)	AP-2608
9-13x	SK306499	Knob (A-BL)	AP-2608
9-14	SK306500	Knob (B)	AP-2609
9-15x	SK306501	Knob (B-BL)	AP-2609
9-16	SK300102	Push Button Knob (L) Part	
9-17x	SK305457	Push Button Knob (P) Part CM-2 CM-2BL	91-5051 91-5051
9-18	BC307073	Dust Cover Comp. AP-206	AP-2601
9-19	TP302926	Hinge (B)	9-4-5
9-20	ZS301580	Screw, oval countersunk head 4x8	
9-21	TP301300	Cover Cushion	AC-3842
9-22x	ZW516611	Nut M3 (AAL)	
9-23x	ZS306799	Screw, pan head 3x14 (Black) (AAL)	

When ordering parts, please describe Parts Number, Description, and Model Number in detail.

SECTION 3

SCHEMATIC DIAGRAM

1. AP-207 NO. 2-1 1562038A SCHEMATIC DIAGRAM
2. AP-307 NO. 2-2 1562039A SCHEMATIC DIAGRAM

TC4030BP

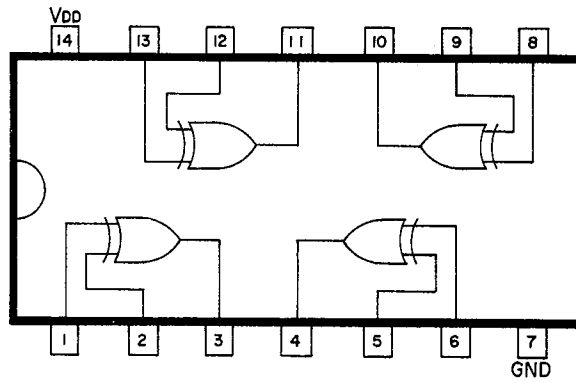

TA75458P

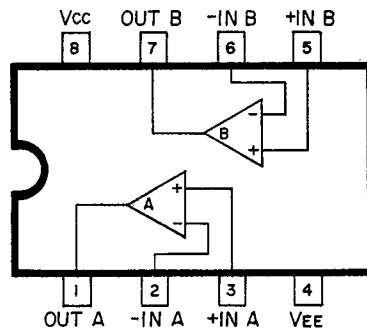

TC4011BP

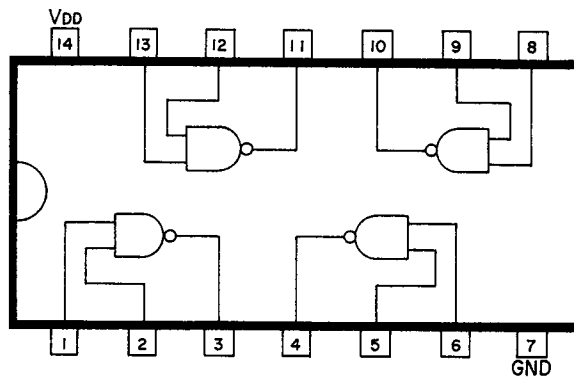

TC4002BP

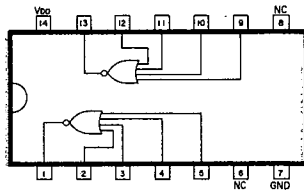

TC4011BP

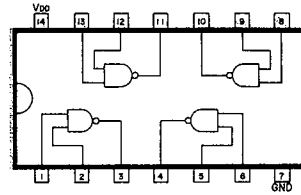

TC4030BP

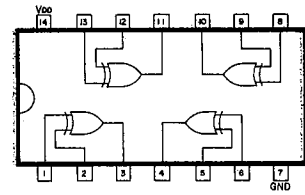

TC4069BP

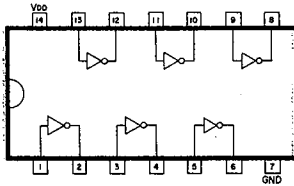

TC4013BP

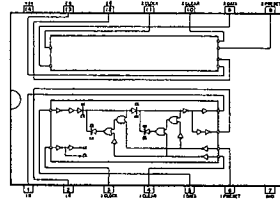

TA75458P

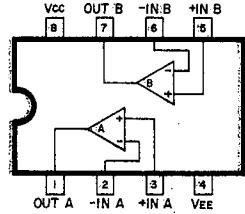

TC5081P

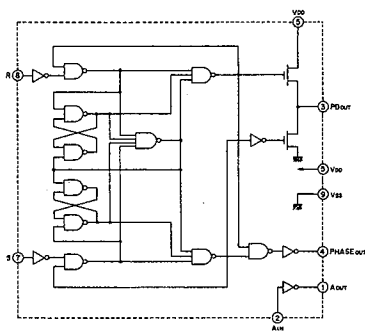

TC4040BP

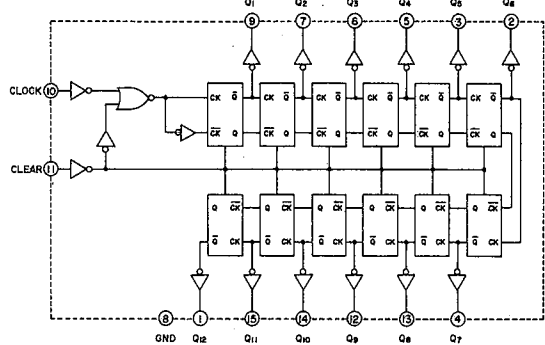

TC5080P

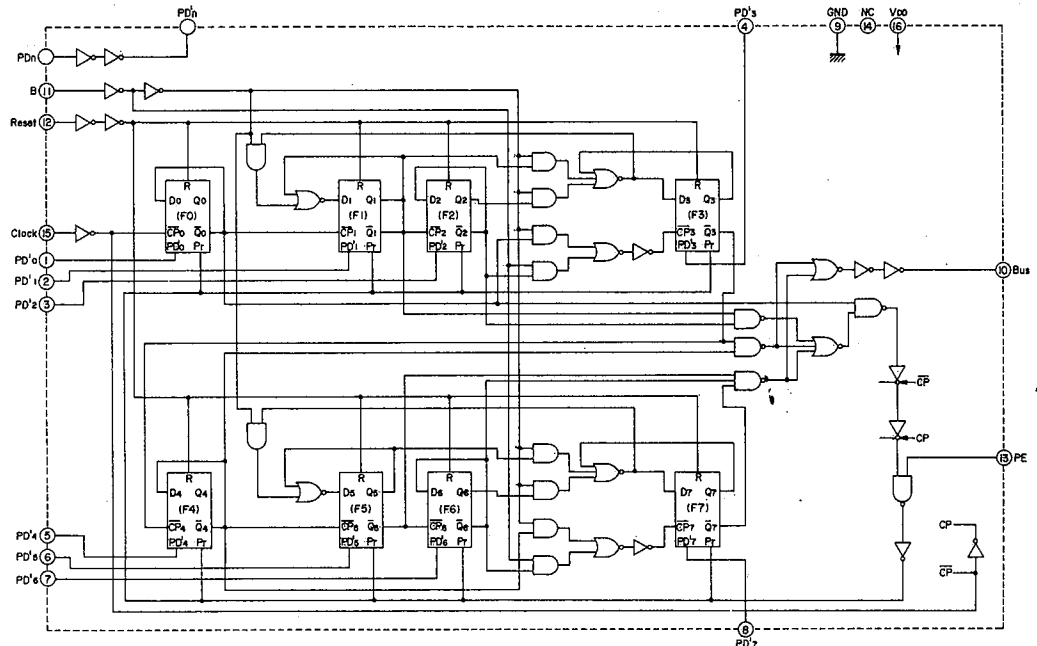

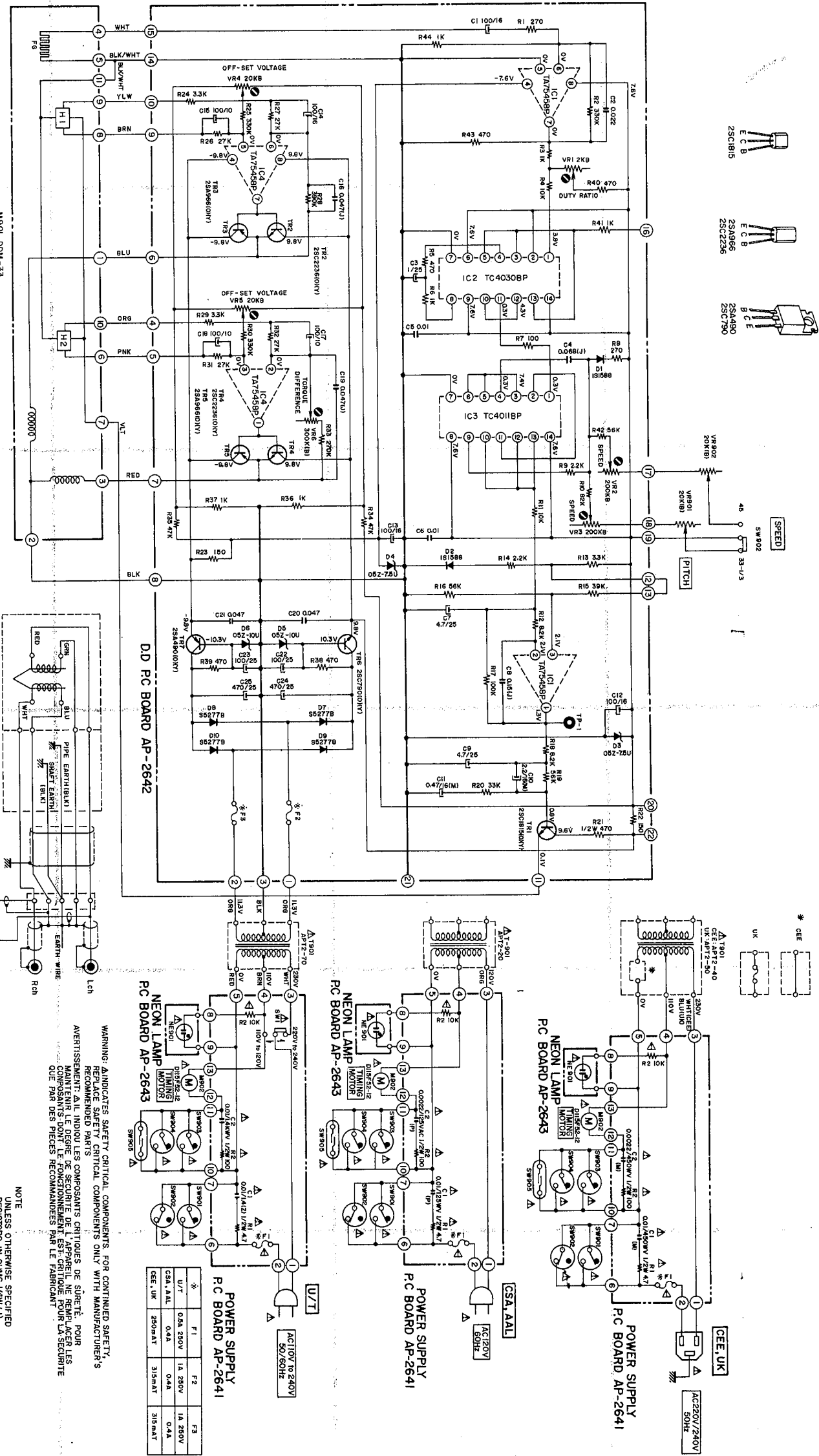

WARNING: INDICATES SAFETY CRITICAL COMPONENTS. FOR CONTINUED SAFETY, REPLACE SAFETY CRITICAL COMPONENTS ONLY WITH MANUFACTURER'S RECOMMENDED PARTS.

AVERTISSEMENT: ALL INDIQUE LES COMPOSANTS CRITIQUES DE SÛRETÉ. POUR MAINTENIR LE DEGRÉ DE SÛRETÉ DE L'APPAREIL, NE REMPLACER LES COMPOSANTS CRITIQUES QUE PAR DES PIÈCES RECOMMANDÉES PAR LE FABRICANT.

NOTE: UNLESS OTHERWISE SPECIFIED RESISTORS IN OHMS (1/4W (1/2) CAPACITORS IN PF 50WV (2)

AP-207
SCHEMATIC DIAGRAM
NO.2-1 1562038A