

GXC 40D

THE QUALITY OF  
THIS MANUAL IS  
THE BEST THAT  
IS AVAILABLE

# AKAI

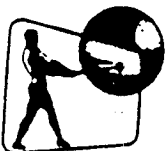

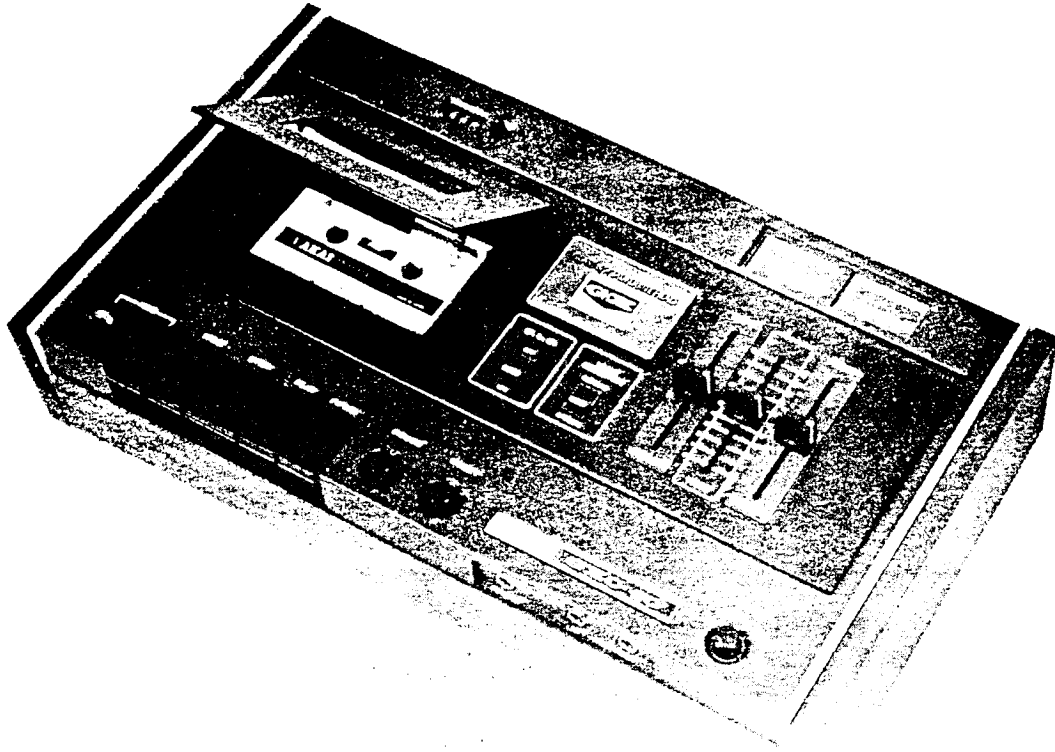

## TABLE OF CONTENTS

I.	SPECIFICATIONS .....	2
II.	MEASURING METHOD .....	3
III.	DISMANTLING OF TAPE TRANSPORT UNIT & AMPLIFIERS .....	5
IV.	MECHANISM ADJUSTMENT .....	6
V.	HEAD ADJUSTMENT .....	9
VI.	AMPLIFIER ADJUSTMENT .....	10
VII.	COMPOSITE VIEWS OF COMPONENTS .....	13
VIII.	SCHEMATIC DIAGRAM	

When placing order for parts,  
Please use separate PARTS LIST.

# I. SPECIFICATIONS

An asterisk next to a figure, indicate the minimum guaranteed performance.

TRACK SYSTEM	4-track 2-channel stereo system	
TAPE SPEED	1 7/8 ips $\pm$ 2% ( $\pm$ 3%*)	
WOW AND FLUTTER	Less than 0.2% RMS ( $\pm$ 0.27% RMS*)	
FREQUENCY RESPONSE	Chromium Tape	30 to 18,000 Hz $\pm$ 3dB (30 to 16,000 Hz $\pm$ 4 dB*)
	Standard Tape	30 to 16,000 Hz $\pm$ 3dB (30 to 15,000 Hz $\pm$ 4 dB*)
SIGNAL TO NOISE RATIO	Better than 45 dB (41 dB*)	
DISTORTION	Less than 2% (3%*) at 1,000 Hz "OVU" recording	
CROSS TALK	Better than 25 dB	
ERASE RATIO	Better than 70 dB	
OUTPUT	Line output	1,228V ( $\pm$ 4dB) $\pm$ 1.5 dB using a 333 Hz "OVU" recorded tape
	Din output	0.4V
	Phone output	30 mV at 8 $\Omega$
	Speaker output	5W/5W continuous power at 8 $\Omega$ (4W/4W*)
INPUT	Mic input	More than 0.2 mV
	Line input	More than 50 mV
	Din input	More than 5 mV
MOTOR	Hysteresis Synchronous outer-rotor motor	
RECORDING CAPACITY	1 hour stereo recording using a C-60 tape	
FAST FORWARD AND REWIND TIME	60 sec. using a C-60 tape	
HEADS	Recording/Playback Head	In-line 4-track 2-channel Glass and Ferrite recording/Playback Head Gap: 1.4 to 1.9 $\mu$ m Impedance: 1,200 $\Omega$ $\pm$ 20% at 1 KHz
	Erase Head	In-line 4-track 2-channel erase head Gap: 0.3 mm Impedance: 195 $\Omega$ $\pm$ 10% at 100 KHz
OSCILLATION FREQUENCY	80 $\pm$ 5 kHz	
TRANSISTORS	4 ...2SC458 LG (C)	GXC-40 only
	4 ...2SC711 (E, F)	2 ...2SA636 (K, L)
	4 ...2SC945 (Q, R)	2 ...2SC871 (E, F)
	2 ...2SC968 (2, 3)	2 ...2SC971 (2, 3) 2 ...2SC1098 (K, L)
IC	2 ...LD-3141	
DIODES	2 ...1N34A	4 ...RV (GXC-40 only)
	2 ...10D1	
	1 ...10DC1 (BLK)	
	1 ...10DC1 (RED)	
POWER SUPPLY	100 to 240V AC, 50/60 Hz	
POWER CONSUMPTION	GXC-40: 50W GXC-40D: 20W	
INSULATION RESISTANCE	More than 50 M ohms	
INSULATION DURABILITY	1,000V AC for more than 1 minute duration	
DIMENSIONS	412 (W) $\times$ 122 (H) $\times$ 222 (D) mm (16.5" $\times$ 4.9" $\times$ 8.9")	
WEIGHT	GXC-40: 5.3 kg (11.7 lbs.) GXC-40D: 5.1 kg (11.3 lbs.)	
REMARKS	Specifications are subject to change	

## II. MEASURING METHOD

### 1. TAPE SPEED DEVIATION

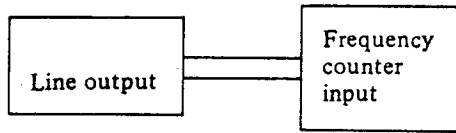

Fig. 1

As shown in Figure 1, connect a Frequency Counter to the Line Output of Model GXC-40.

Take a frequency counter reading at the beginning, middle, and end of tape winding during playback. The maximum value of these respective readings will represent tape speed deviation.

### 2. WOW AND FLUTTER

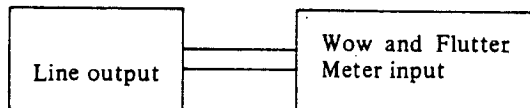

Fig. 2

#### Method A

As shown in Fig. 2, connect the Line Output of Model to the Input of a Wow and Flutter Meter.

Use a 3,000 Hz. pre-recorded test tape and take a wow and flutter meter reading at the beginning, middle, and end of tape winding. The maximum value of these respective readings will represent the wow and flutter.

#### Method B

Supply a 3,000 Hz. sine wave signal from an Audio Frequency Oscillator and make a recording on a blank tape at the beginning, middle, and end of tape winding. Rewind and play tape. Measure wow and flutter with a Wow and Flutter Meter. (The wow and flutter value of Method B will be close to twice that of Method A).

**Play back a 333 Hz. "O" VU pre-recorded test tape and measure the output.**

### 3. FREQUENCY RESPONSE

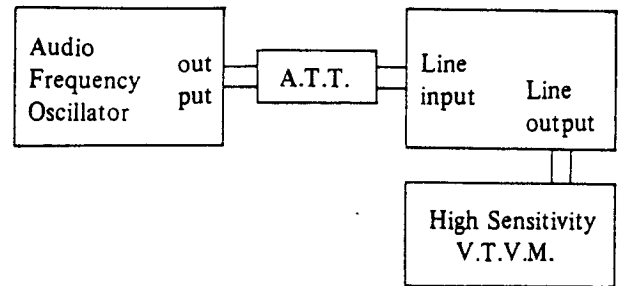

Fig. 3

For measuring frequency response, connect instruments as shown in Fig. 3 and proceed as follows:

- 1) Supply a 1,000 Hz. sine wave to the Line Input of Model from an Audio Frequency Oscillator through an Attenuator. Set recorder to recording mode and turn recording level volume control to maximum. Adjust attenuator to obtain a +4 dB V.T.V.M. reading.
- 2) Under conditions described in 1.) above, re-adjust attenuator so that the Line Output is -16 dB, and record 30 to 15,000 Hz. spot frequencies.
- 3) Rewind cassette tape and playback from the beginning. Take V.T.V.M. spot frequency readings and plot values on a graph.

Note: When measuring frequency response, use low noise tape and set Tape Selector Switch to "Normal" position.

("Special" position is for chromium dioxide tape).

### 4. SIGNAL TO NOISE RATIO

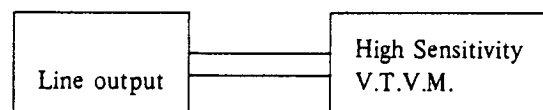

Fig. 4

As shown in Fig. 4, connect a high sensitivity V.T.V.M. to the Line output of Model

Then remove the tape and measure the noise level under the same condition. Convert each of the measured values into decibels.

## 5. TOTAL HARMONIC DISTORTION FACTOR

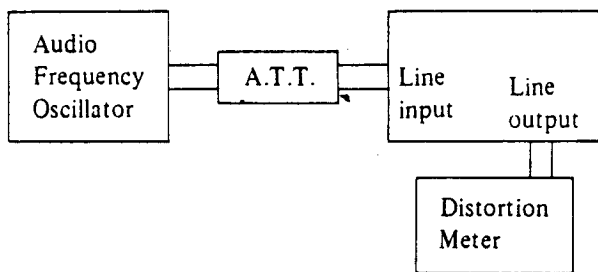

Fig. 5

Connect the measuring instruments as shown in Fig. 5 and record a 1,000 Hz. sine wave signal at "0" VU. Playback the resultant signal and measure the overall distortion factor.

Measure the noise level of the tape recorder without the tape. Connect the audio frequency oscillator directly to the distortion meter for measurement of the distortion factor of the oscillator. The required distortion factor can be obtained from the results of the above measurement by the following formula:

$$d_0 = d - d_1 - d_2$$

where,  $d_0$  = Required distortion factor  
 $d$  = Overall distortion factor  
 $d_1$  = Noise level  
 $d_2$  = Distortion factor of the oscillator

Note: When measuring the distortion factor, new tape should be used.

## 6. CROSS TALK (Cross talk between the channels)

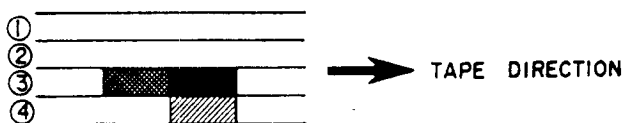

Fig. 6

As shown in Fig. 6, first record a 1,000 Hz. sine wave signal on Track No. 3 at +3 VU Level. Next, record under a non-input condition. Then, playback the tape on Tracks No. 3 and 4 through the B.P.F. (band pass filter sensitivity ..... 1:1) and obtain a ratio between the two from the following formula:

$$C = 20 \log \frac{E_0}{E_2 - E_1} \text{ (dB)}$$

where,  $C$  = Desired cross talk ratio (dB)  
 $E_0$  = 1,000 Hz. signal output level   
 $E_2$  = 1,000 Hz. cross talk level   
 $E_1$  = Non-input signal recorded level

## 7. ERASE RATIO

As shown in Fig. 4, connect a high sensitivity V.T.V.M. to the Line Output of Model

Playback a virgin tape and take a V.T.V.M. reading of the output level. Next, record a 1,000 Hz. sine wave signal at +3 dB, then playback this recorded signal and take a V.T.V.M. reading of the output level. Next, using this pre-recorded tape, record under a non-input condition and take a reading of the noise level output of the erased signal and obtain a ratio between the two from the following formula:

$$E_r = 20 \log \frac{E_0}{E_2 - E_1}$$

where,  $E_r$  = Desired erase ratio (dB)  
 $E_0$  = 1,000 Hz signal output level  
 $E_2$  = Non-Input signal recorded level  
 $E_1$  = Virgin tape noise output level

## 8. POWER OUTPUT

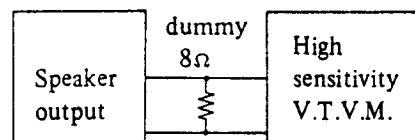

Fig. 7

As shown in Fig. 7, connect an 8Ω dummy load resistor to the speaker output of Model and connect this terminal to a high sensitivity V.T.V.M.

Playback a 333 Hz. "0" VU pre-recorded test tape and take a V.T.V.M. reading of the output level. The resultant output can be obtained from the results of the above measurement by using the following formula:

$$P = \frac{E^2}{R} \text{ (W)}$$

where,  $P$  = Desired power output (watts)  
 $E$  = Measured voltage (R.M.S.)  
 $R$  = 8Ω

For Service Manuals Contact  
**MAURITRON TECHNICAL SERVICES**  
 8 Cherry Tree Rd, Chinnor  
 Oxon OX9 4QY  
 Tel:- 01844-351694 Fax:- 01844-352554  
 Email:- enquiries@mauritron.co.uk

# III. DISMANTLING OF TAPE TRANSPORT UNIT & AMPLIFIERS

In case of trouble, etc. necessitating disassembly, please disassemble in the order shown in photographs. Reassemble in reverse order.

1.

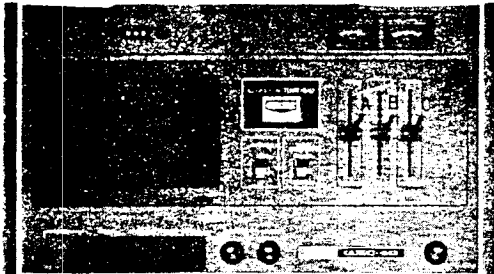

VOLUME & TONE CONTROL KNOBS

2.



LOWER COVER

3.

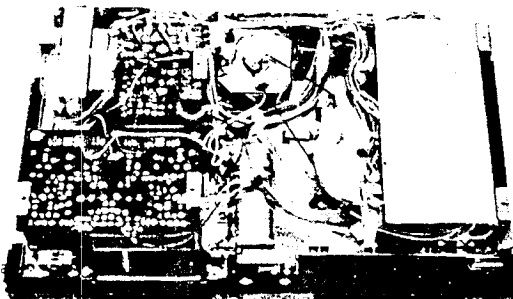

SCREWS

4.



SCREWS

5.

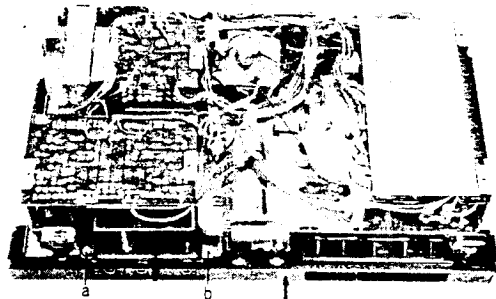

Loosen these Screws only slightly UPPER COVER

6.

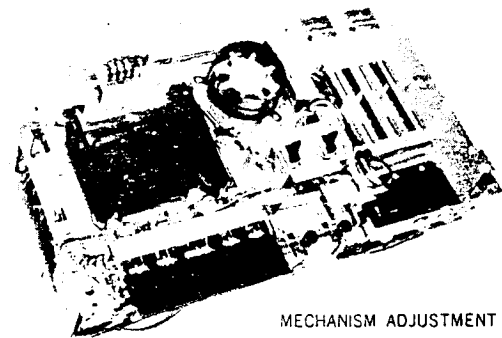

MECHANISM ADJUSTMENT

7.

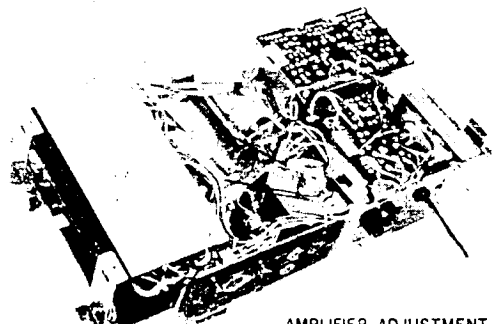

AMPLIFIER ADJUSTMENT

## IV. MECHANISM ADJUSTMENT

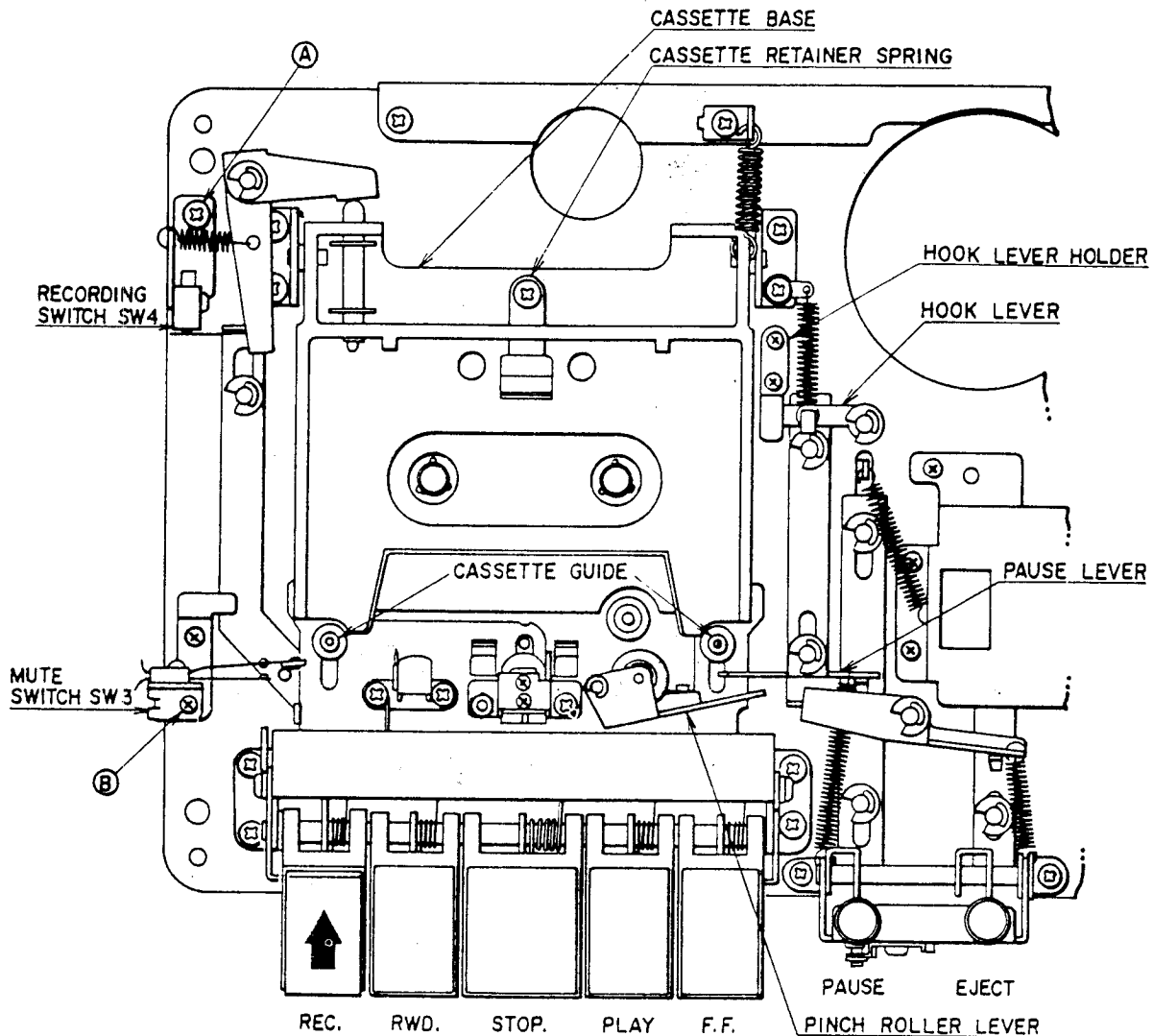

Fig. 8

### 1. RECORDING SWITCH "SW-4" POSITION ADJUSTMENT (See Fig. 8)

Loosen Screw (A) and move the plate to which Recording Switch SW-4 (micro switch) is installed. Position so that when the Rec. Key is depressed, SW-4 turns on perfectly.

At this time, confirm that the recording lamp lights and that Rec/P.B. Switch "SW-1" enters Rec. position perfectly.

### 2. MUTE SWITCH "SW-3" POSITION ADJUSTMENT

Loosen Screw (B) and adjust the angle of the mute switch maintenance plate so that at Rec. or Play mode, SW-3 mute switch contact point releases perfectly and the space of this contact point is not too open.

### 3. PAUSE LEVER POSITION ADJUSTMENT (See Fig. 8)

If at Play mode, the pinch roller lever and pause lever touches, the pinch roller pressure becomes weak, and if this space is too wide, the pinch roller will not sufficiently release at Pause mode.

Therefore, at play mode, adjust the space between pinch roller lever and pause lever to about 0.5mm by slightly bending the pause lever.

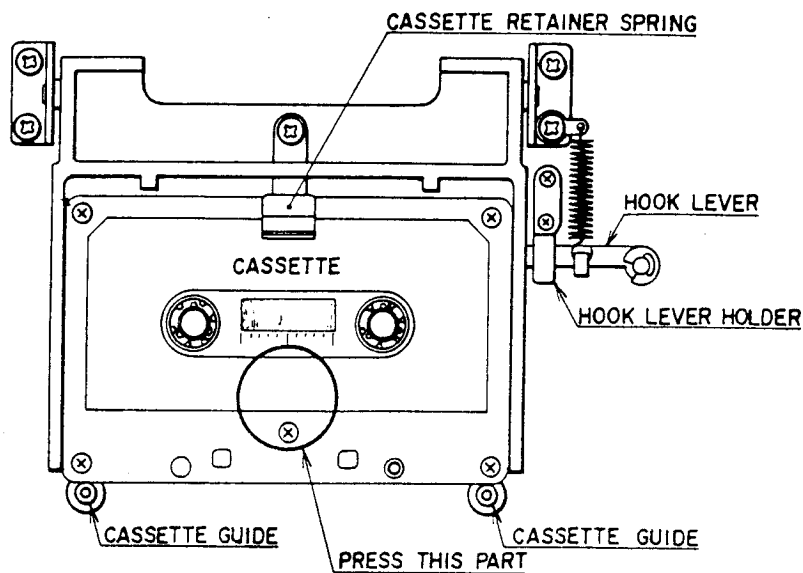

Fig. 9

#### 4. HOOK LEVER HOLDING PLATE ADJUSTMENT (See Fig. 9)

Load a cassette tape onto cassette plate and bend the hook lever holding plate so that when the cassette is lightly pressed downward with your finger at the center part of the cassette, the cassette plate locks when the cassette touches the cassette well.

**Caution:**

If the hook lever holding plate is bent too much, when the top panel is put back on, the cassette plate cannot assume locked position.

#### 5. CASSETTE HOLDER SPRING ADJUSTMENT (See Fig. 9)

If the pressure of the cassette holder spring is too strong, the cassette cannot eject, and if the pressure is too weak, head to tape contact becomes poor at play mode. Considering this, properly adjust the bending angle of the cassette holder spring.

#### 6. F. FWD AND RWD. IDLER BLOCK POSITION ADJUSTMENT (See Fig. 10)

At stop mode, loosen Screw (A) and adjust the angle of the intermediate pulley spring so that the F. Fwd and Rwd idlers do not touch either reel table.

#### 7. CONFIRMATION OF WINDING WHEEL CLUTCH OPERATION

- 1) At rewind mode, when the cassette tape is completely rewound, confirm that the rotation of Winding Wheel A continues and the rotation of Winding Wheel B and the Rewind Idler stops. Also confirm that there is proper clutch slippage between winding wheels A and B.
- 2) In case Winding Wheel B fails to stop perfectly, because the Rewind Idler is not properly pressing against the supply reel table, adjust the bending of rewind lever extremity (see Fig. 10) so that the rewind lever applies stronger pressure to the supply reel table.
- 3) At the end of F. Fwd, make the same check as described above and confirm proper clutch operation between Winding Wheels A and B. In case of imperfect clutch operation, strengthen F. Fwd. idler pressure by adjusting the bending of F. Fwd. lever extremity.



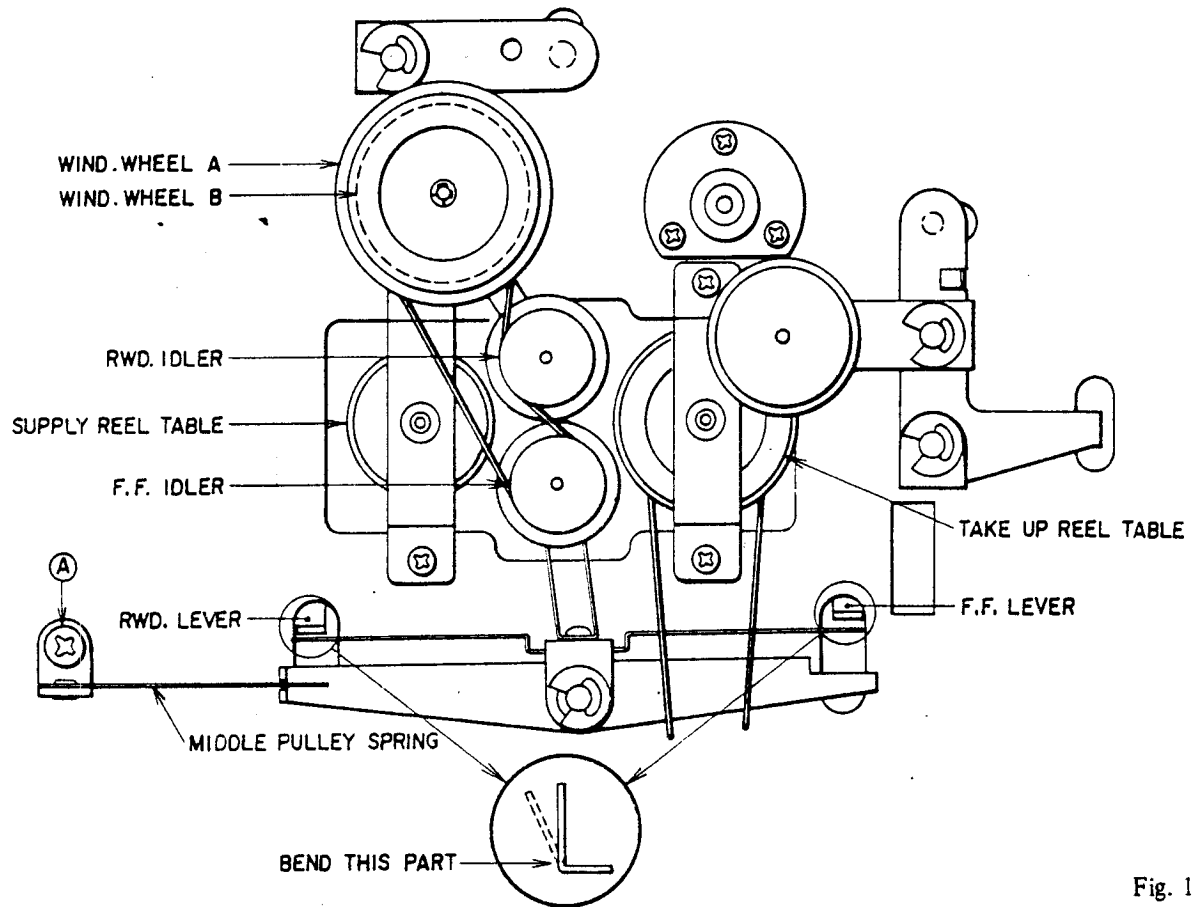

Fig. 10

## V. HEAD ADJUSTMENT

---

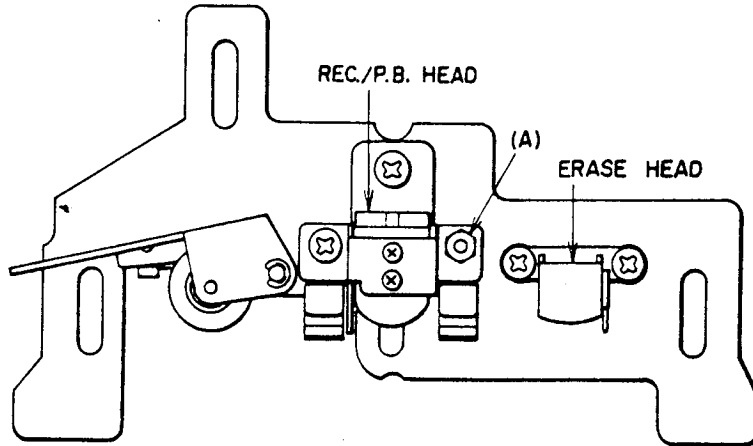

Fig. 11

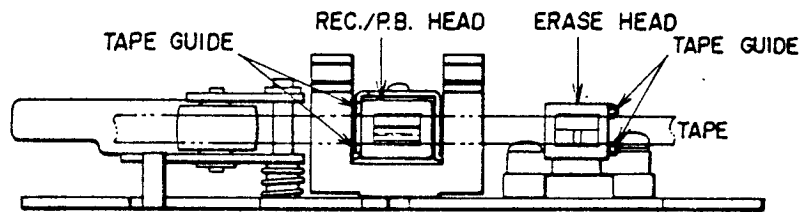

Fig. 12

### REC/P.B. HEAD AZIMUTH ALIGNMENT (See Figs. 11, 12)

Connect a high sensitivity V.T.V.M. (Model 161A) to the Line Output and playback a 10 kHz pre-recorded tape.

Adjust Nut (A) so that the V.T.V.M. indication is maximum.

## VI. AMPLIFIER ADJUSTMENT

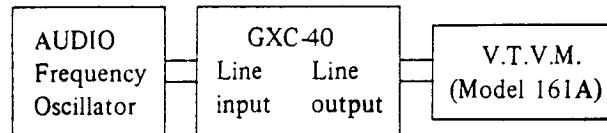

Fig. 13

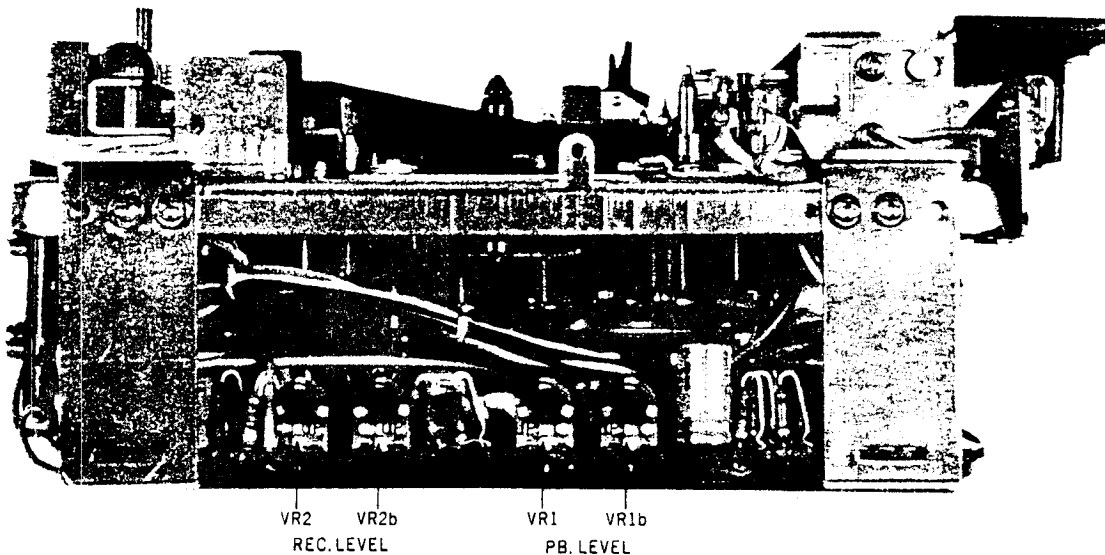

Fig. 14

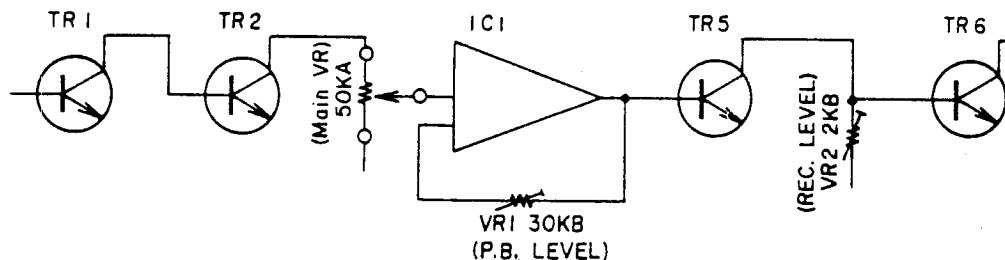

Fig. 15

### 1. PLAYBACK LEVEL ADJUSTMENT (See Figs. 13 to 15)

- 1) Connect a high sensitivity V.T.V.M. (Model 161A) to the Line Output.
- 2) Set main volume control (50 KA) to maximum.
- 3) Playback a 333 Hz "O" VU pre-recorded tape and turn potentiometer VR1 and VR1b (30 KB) until the line output level reaches +4 dB (1.228V).

### 2. RECORDING AND PLAYBACK ADJUSTMENT (See Figs. 13 to 15)

- 1) Load a blank low noise tape and set Tape Selector to "Normal" position.
- 2) Set recorder to recording mode and main volume control (50 KA) to maximum.
- 3) Supply a 1,000 Hz sine wave signal from an Audio Frequency Oscillator through the Attenuator to the Line Input. Adjust the attenuator so that the V.T.V.M. indicates +4 dB (VU needle indicates "O" VU).
- 4) After a few seconds of recording, playback the recorded tape from the starting point and check the V.T.V.M. indication.
- 5) If the line output does not reach +4 dB, repeat recording and playback procedure from Item 3), and adjust potentiometer VR2 and VR2b (2 KB) until +4 dB is obtained.

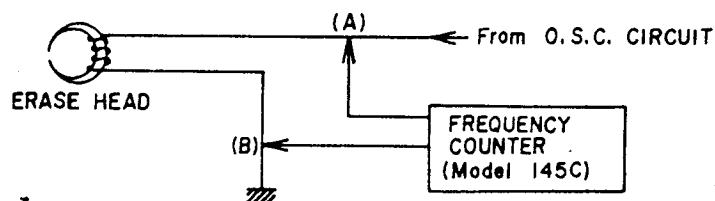

Fig. 16

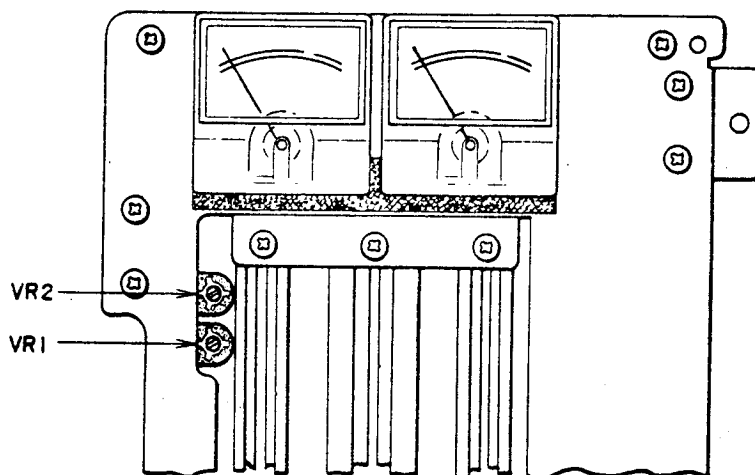

Fig. 17

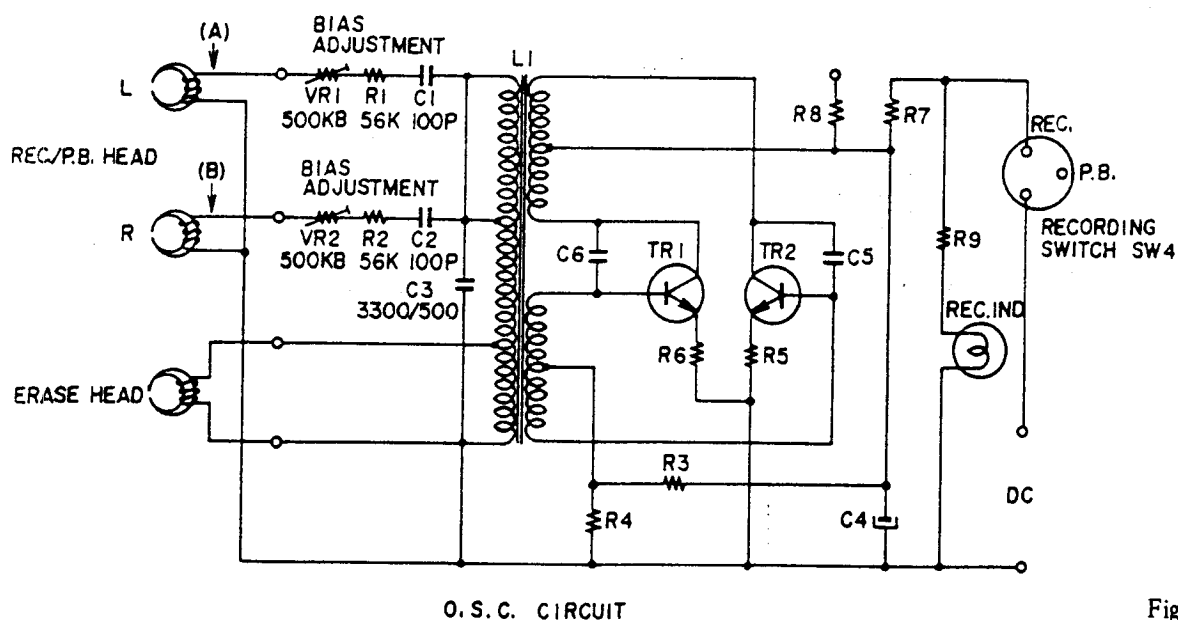

Fig. 18

### 3. RECORDING BIAS FREQUENCY ADJUSTMENT (See Fig. 16)

Connect a Frequency Counter to points (A) and (B) in Fig. 16 of the Erase Head and read the frequency indication.

If the frequency counter reading is  $80 \pm 5$  kHz, the recording bias frequency is correct.

If the recording bias frequency is incorrect, it can be adjusted by changing the value of condenser C3 (3300p 500wV) of the oscillator P.C. Board.

### 4. RECORDING BIAS VOLTAGE ADJUSTMENT (See Figs. 17, 18) (Frequency Response Adjustment)

Playback the 1,000 Hz. and 10,000 Hz. signals recorded in Frequency Response Measuring Method procedure and adjust Bias Adjustment Volume VR-1, VR-2 (500 KB) as shown in Figs. 17 and 18 so that the output level of these two frequencies are equal.

The bias voltage at this time is from 4 to 26V AC.

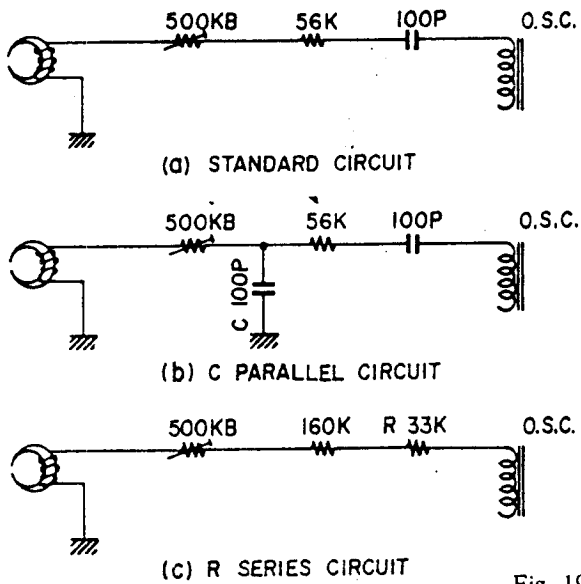

Fig. 19

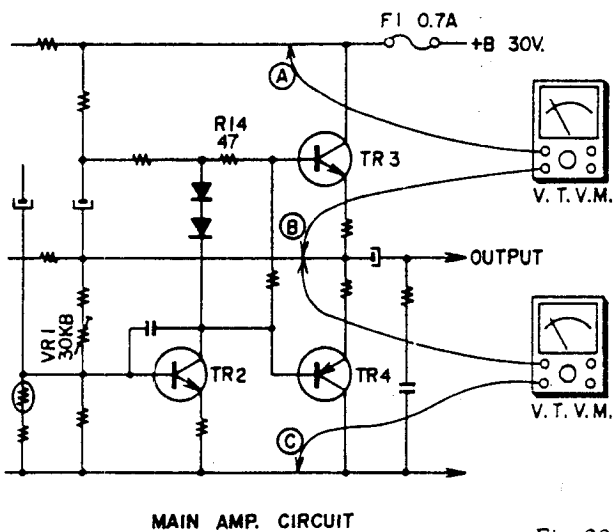

Fig. 20

**NOTE:**

1. Electric shock will cause the GX Head to become magnetized and once the head becomes magnetized, distortion is predominant. Consequently, it is important that the head always be demagnetized with a large type demagnetizer following bias voltage check.
2. On machines employing the bias adjustment circuits shown in (b) and (c) of Fig. 19, after the Rec/Playback Head has been replaced, it becomes impossible to adjust the bias voltage. In this case, replace with the circuit shown in (a) of Fig. 19 and adjust bias voltage.

**5. ERASE VOLTAGE**

There is no way to adjust the erase voltage, but correct erase voltage when the Tape Selector is set to "Normal" is about 21V, and when set to "Special", about 28V.

**6. MAIN AMP VOLTAGE BALANCE ADJUSTMENT**

As shown in Fig. 20, connect a V.T.V.M. between points (A) (B) as well as between (B) (C) and adjust variable resistor VR1 (30 KB) so that the V.T.V.M. indication is half the value of the supply voltage.

There is no way to adjust the "no signal current", but the correct "no signal current" is 5 mA. When a power transistor is replaced and a signal introduced, if cross-over distortion is considerable, it can be reduced by changing resistor R-14 47Ω to about 33Ω.



MAIN AMPLIFIER P.C. BOARD (CG-5009)

TR1--2SC871(E,F) TR2--2SC971(2,3) TR3--2SC1098(K,L) TR4--2SA636(K,L)

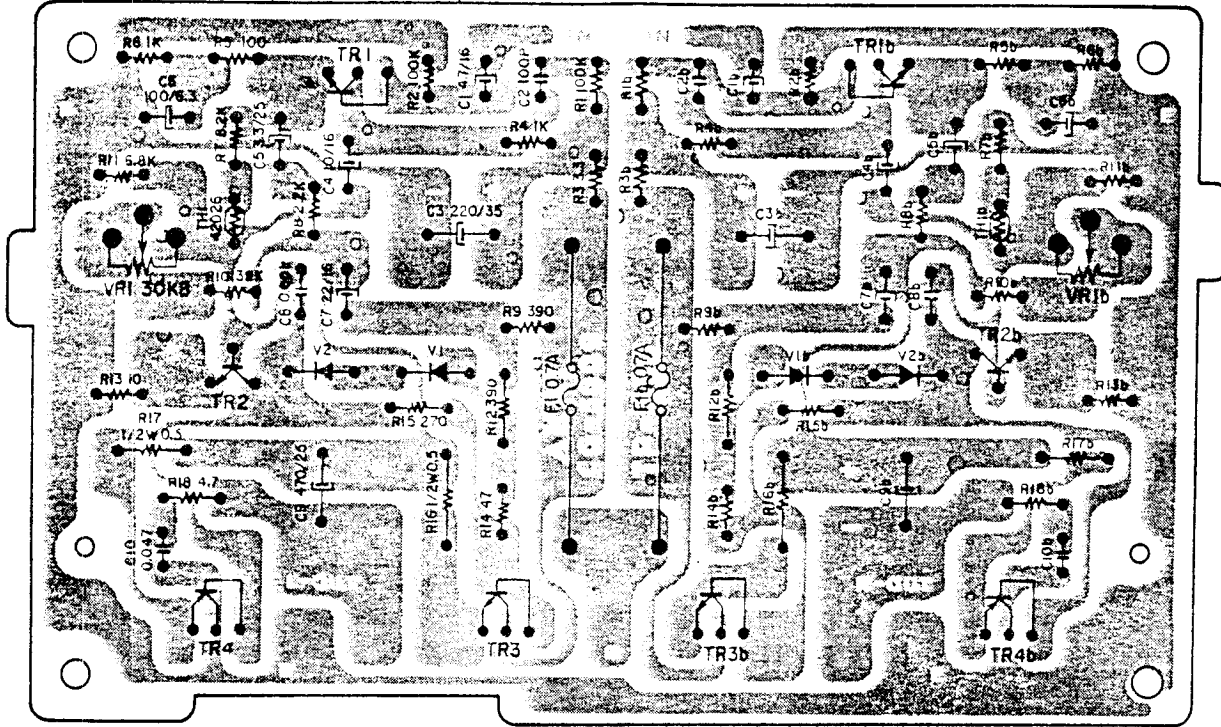

POWER SUPPLY & OSCILLATOR P.C. BOARD (CG-5011)

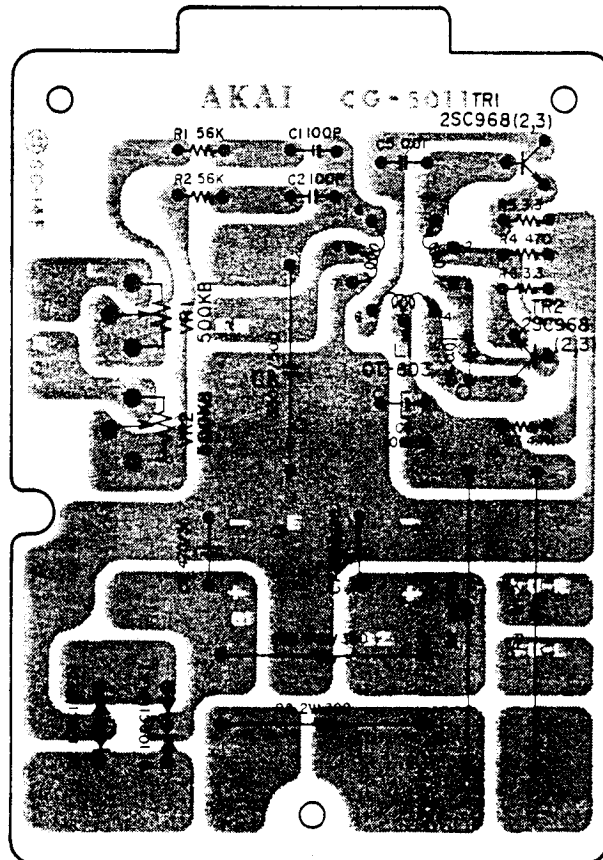

## HOW TO USE THIS PARTS LIST

1. This parts list is compiled by various individual blocks based on assembly process.
2. When ordering parts, please describe parts number, serial number, and model number in detail.
3. How to read List

The reference number corresponds with illustration or photo number of that particular parts List.

This number corresponds with the Figure Number.

This number corresponds with the individual parts index number in that figure.

A small "x" indicates the inability to show that particular part in the Photo or Illustration.

Schematic Diagram Number of individual manufactured part. (not required for parts order)

Quantity of particular part required.

Ref. No.	Parts No.	Description	Schematic No.	Q'ty
<b>FLYWHEEL BLOCK #13</b>				
12-115x	800425	Flywheel Block Assy. Comp.	RDG#13	1
12-116	244506	Flywheel Only	RD-233	1
12-117x	244754	Felt, Flywheel	RD-275	1
12-118	251324	Main Metal Case	RD-236	1
12-119	253080	Main Metal	RD-237	1

4. Both the kind of part and installation position can be determined by the Parts Number. To determine where a parts number is listed, utilize Parts Index at end of Parts List.  
It is necessary first of all to find the Parts Number. This can be accomplished by using the Reference Number listed at right of parts number in the Parts Index. (meaning of ref. no. outlined in Item 3 above).
5. Utilize separate "Price List for Parts" to determine unit price. The most simple method of finding parts Price is to utilize the reference number.

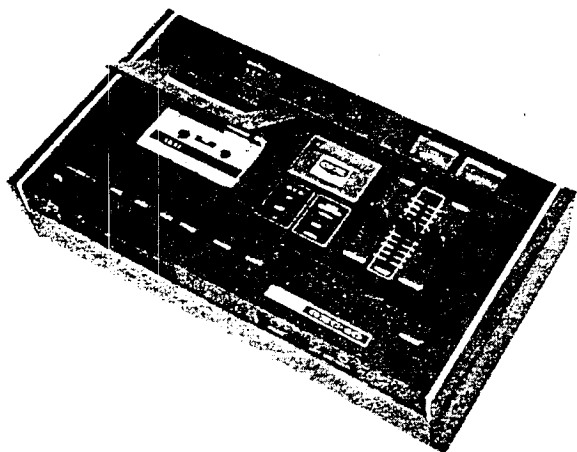

## TABLE OF CONTENTS

FIG. 1	HEAD BASE BLOCK (CG)	2
FIG. 2	MOTOR BLOCK	3
FIG. 3	REEL TABLE BLOCK	4
FIG. 4	MECHANISM ASSEMBLY BLOCK (1)	5
FIG. 5	MECHANISM ASSEMBLY BLOCK (2)	6
FIG. 6	AMP. CHASSIS BLOCK	8
FIG. 7	MAIN AMP. P.C. BOARD (CG-5009)	9
FIG. 8	PRE-AMP. P.C. BOARD (CG-5010)	10
FIG. 9	POWER SUPPLY & OSC. P.C. BOARD (CG-5011)	11
FIG. 10	POWER & JACK PLATE BLOCK	12
FIG. 11	FINAL ASSEMBLY BLOCK	13
FIG. 12	KEYBOARD SWITCH BLOCK	15
INDEX		16



FIG. 1 ILLUSTRATION OF HEAD BASE BLOCK (CG)

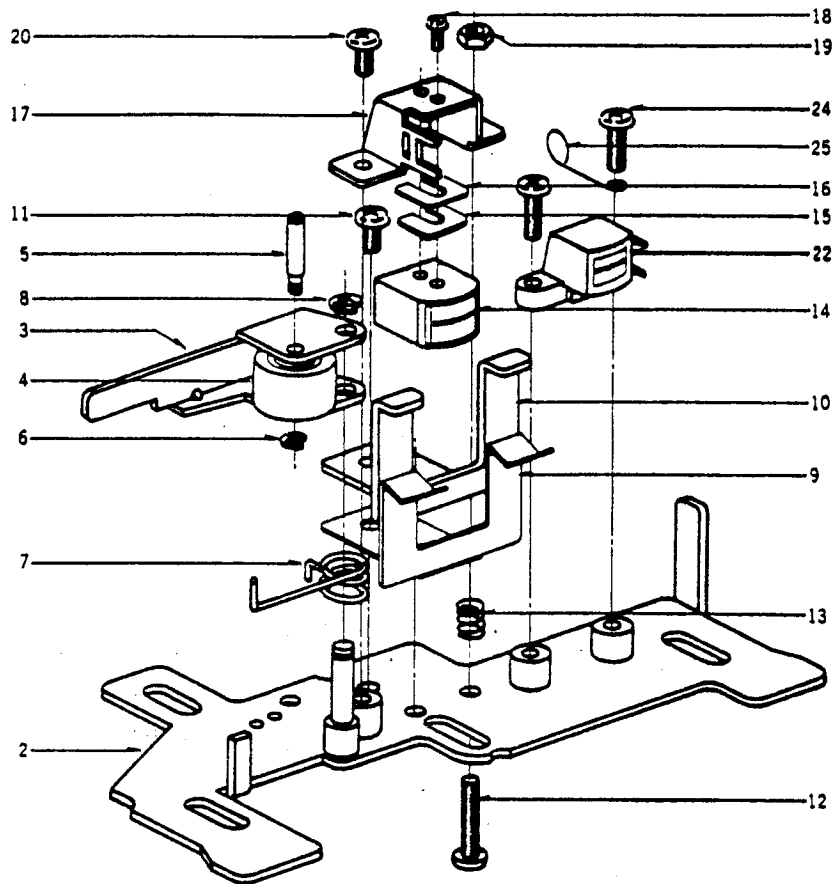

HEAD BASE BLOCK (CG)

Ref. No.	Parts No.	Description	Schematic No.	Q'ty
1-1x	451708	Head Base Block (CG) Assy.		
		Comp.	CG	1
1-2	457323	Head Base, w/prop	CG-0001 to 4	4
1-3	457391	Pinch Roller Arm	CG-0010	1
1-4	468292	Pinch Roller CG	CG-0032	1
1-5	389981	Pinch Roller Shaft	CS-0011	1
1-6	391397	"E" Ring 1.2M	6-1-9	1
1-7	457380	Pinch Roller Spring	CG-0009	1
1-8	270088	"E" Ring 1.9M	6-1-9	1
1-9	457378	Cassette Retaining Spring (2)	CG-0008	1
1-10	457367	Cassette Stopper Base	CG-0007	1
1-11	417137	Screw, binding head 3x4		2
1-12	462881	Screw, binding head 2.3x12		1
1-13	465636	Angle Adjusting Spring	CG-0029	1
1-14	451934	REC./PB. HEAD P4-330	P4-330	1
1-15	414235	Washer A (PBP2-H) 0.1t	CS-0025	1
1-16	414246	Washer B (PBP2-H) 0.15t	CS-0025	1
1-17	366625	PC. Tape Guide	RCC-1012	1
1-18	461395	Screw, round head 2x3		2
1-19	273688	M2.3 Nut		1
1-20	417273	Screw, binding head 2.3x4		1
1-21x	462892	Head Terminal Plate	CG-0028	1
1-22	451945	ERASE HEAD E4-150	E4-150	1
1-23x	273633	M2.3 Earth Lug		1
1-24	417227	Screw, binding head 2.3x5		2
1-25	399071	Head Lead-in Wire Hook	CS-0021	1

When ordering parts, Please describe Parts Number, Serial Number, and Model Number in detail.

FIG. 2 ILLUSTRATION OF MOTOR BLOCK

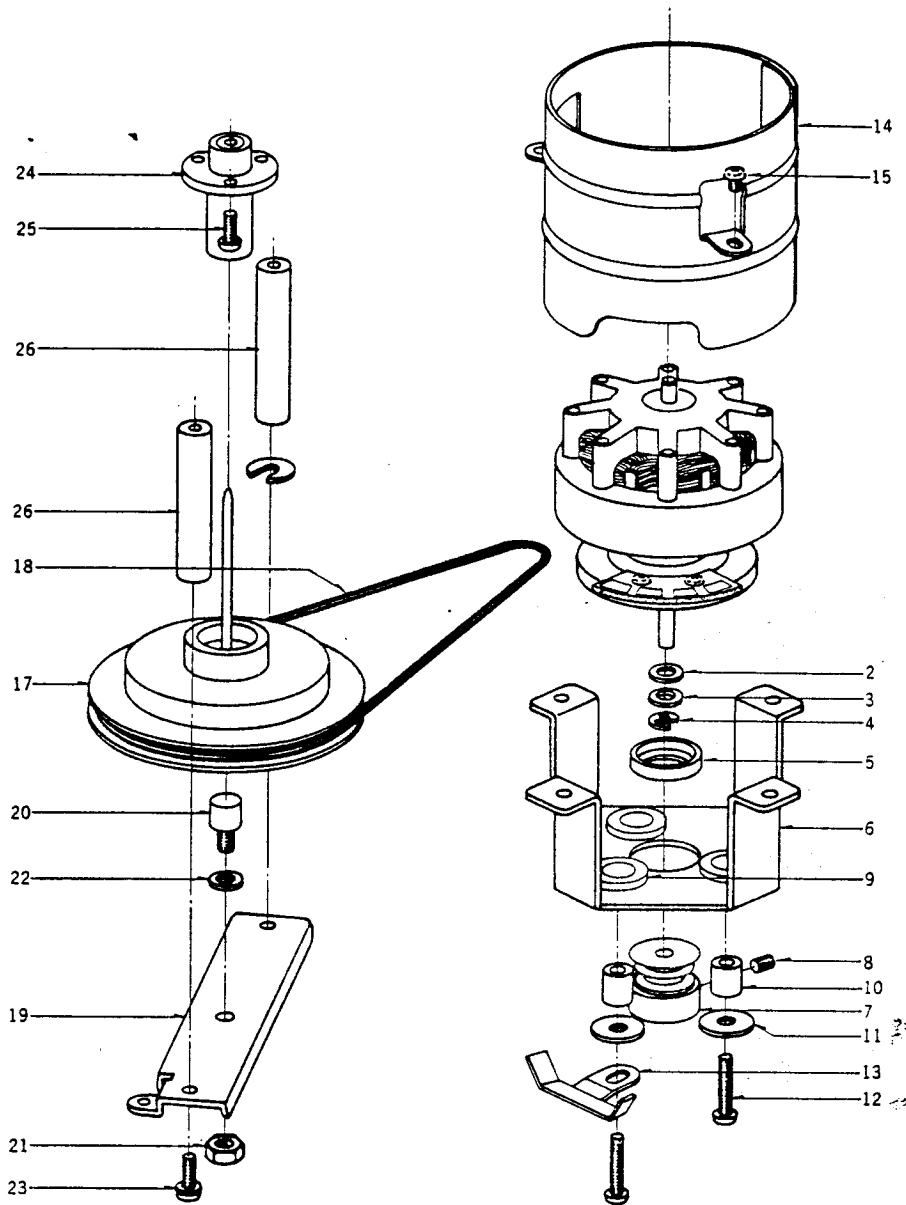

MOTOR BLOCK

Ref. No.	Parts No.	Description	Schematic No.	Q'ty	Ref. No.	Parts No.	Description	Schematic No.	Q'ty
2-1x	451675	CG Motor Assy. Comp.	CG	1	2-15	417251	Screw, binding head 2.3x3		2
2-2	396415	CS Thrust Washer A (Teflon)	CS-7029	3	2-16x	413155	Screw, binding head 3x6		4
2-3	396426	CS Thrust Washer B (Nylon)	CS-7029	3	2-17	456647	Capstan Shaft, w/Flywheel	CG-1020, 1	1
2-4	270101	"E" Ring 3.0M	6-1-9	1	2-18	456660	Capstan Belt	CG-1023	1
2-5	394075	Oil Cut	CS-7028	1	2-19	456682	Capstan Supporting Plate	CG-1022	1
2-6	457301	Motor Bracket	CG-7002	1	2-20	387268	Flywheel Support	CS-1115	1
2-7	457290	Motor Pulley	CG-7001	1	2-21	413188	M4 Nut		1
2-8	356804	Set Screw, hexagon socket 3x4		2	2-22	420682	Washer (Nylon) 4,2x9x0.5t		1
2-9	384164	Rubber Cushion Bush	24x0-717	3	2-23	417025	Screw, binding head 3x8		2
2-10	469563	Rubber Cushion Sleeve CG	CG-7010	3	2-24	456625	Capstan Metal Case, w/washer	CG-1017, 8	1
2-11	402322	Washer (SUP) 4,1x13x0.5t		3	2-25	417227	Screw, binding head 2.3x5		3
2-12	417148	Screw, binding head 3x15		3	2-26	456671	Capstan Supporting Prop	CG-1016	2
2-13	468270	Belt Vibration Stopper	CG-7008	1	2-27x	417025	Screw, binding head 3x8		2
2-14	456614	Motor Shield A	CG-1068	1			w/washer		2

When ordering parts, Please describe Parts Number, Serial Number, and Model Number in detail.



FIG. 4 ILLUSTRATION OF MECHANISM ASSEMBLY BLOCK (1)

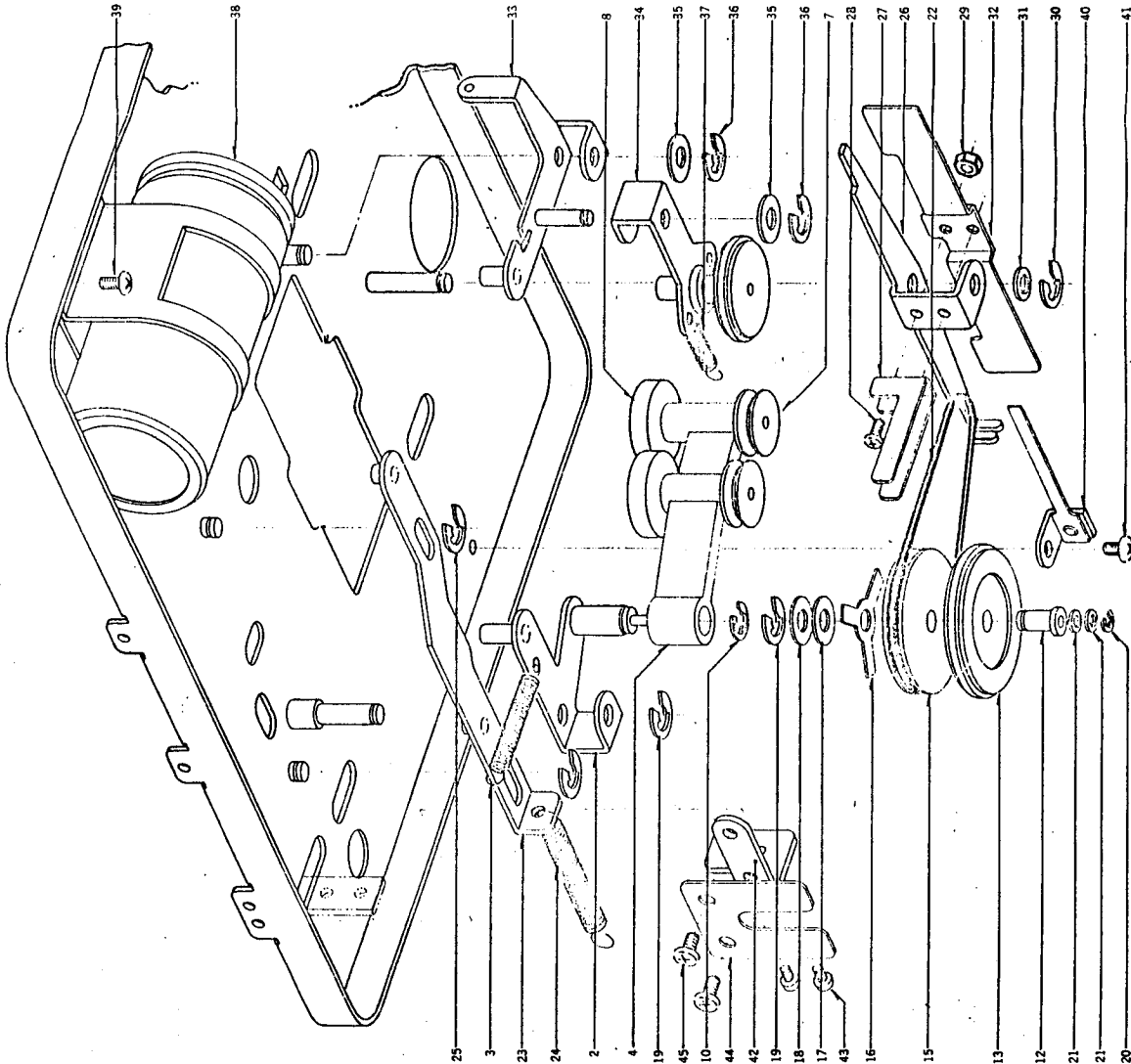

MECHANISM ASSEMBLY BLOCK (1)

Ref. No.	Part No.	Description	Schematic No.	Qty
4-1x	WIND IDLER BLOCK (CG)			
4-2	459966	Wind Idler Block Comp.	CC	1
4-3	456783	Wind Lever (1), w/shaft	CC-209	1
4-4	392804	Auto Changing Lever E Return Spring	CS-256	1
4-5x	456827	Wind Lever (2), w/metal	CC-205	1
4-6x	456851	Wind Pulley Shaft (1) (L=22.5)	CC-203	1
4-7x	456852	Wind Pulley Shaft (2) (L=28.5)	CC-203	1
4-8	456836	Wind Pulley (1)	CC-206	2
4-9	456837	Wind Pulley (2)	CC-207	2
4-9x	381644	Washer (Polyalder)		4
4-10	270133	"E" Ring 4.0M 2.1x4.0x0.13t	6-1-9	4
4-11x	462690	Wind Wheel Sub Assy Comp.	CC	1
4-12	461378	Wheel Collar	CC-206	1
4-13	461880	Wind Wheel (1) Comp.	CC-202	1
4-14x	461586	Clutch Felt	CC-202	1
4-15	461891	Wind Wheel (2)	CC-204	1
4-16	459224	Clutch Spring	CC-202	1
4-17	259795	Washer (SUP) 4.3x11x0.13t		1
4-18	421007	Washer (SUP) 4.3x11x0.25t		1
4-19	394284	"U" Ring 1.85M	6-1-1	2
4-20	391397	"E" Ring 1.25M	6-1-9	1
4-21	381644	Washer (Polyalder)		2
4-22	456895	Wind Belt 2.1x4.0x0.13t	CC-105	1
<b>MECH. FRAME BLOCK</b>				
4-23	456926	Wind Slide w/pin	CG-104	1
4-24	224796	New Spring D	6-1-12	1
4-25	200283	"U" Ring 2.85M	6-1-1	2
4-26	456974	Wind Lever (3)	CG-104	1
4-27	456985	Wind Spring	CG-105	1
4-28	417227	Screw, binding head 2.3x5		2
4-29	273688	M2.3 Nut		2
4-30	290283	"U" Ring 2.85M	6-1-1	2
4-31	259739	Washer (Polyalder) 4.1x7x0.25t	CG-103	1
4-32	460484	Wind Part Spring	CG-102	1
4-33	456982	Take-up Lever (1), w/shaft	CG-103	1
4-34	456983	Washer (PB) 4.2x11x0.35t		2
4-35	456984	"U" Ring 2.35M	6-1-1	2
4-36	294593	Take-up Lever Spring	CG-101	1
4-37	464315	MP Capacitor 6r14F	3x9-47	1
4-38	393671	150VV AC		1
4-39	447840	Tapping Screw #2 3x8 (RR)	CG-106	1
4-40	391285	Middle Pulley Spring, w/retainer	CG-106.1	1
4-41	447772	Tapping Screw #2 3x6 (HR)		1
4-42	457053	Rec. Bracket	CG-101	1
4-43	417273	Screw, binding head 2.3x4		2
4-44	457043	Rec. Spring	CG-102	1
4-45	471137	Spring head 3x4		2
4-46x	453374	Knobbed Screw	5.5.51	1
4-47x	447772	Tapping Screw #2 3x6 (BR)		4

When ordering parts, Please describe Part Number, Serial Number, and Model Number in detail.

FIG. 5 ILLUSTRATION OF MECHANISM ASSEMBLY BLOCK (2)

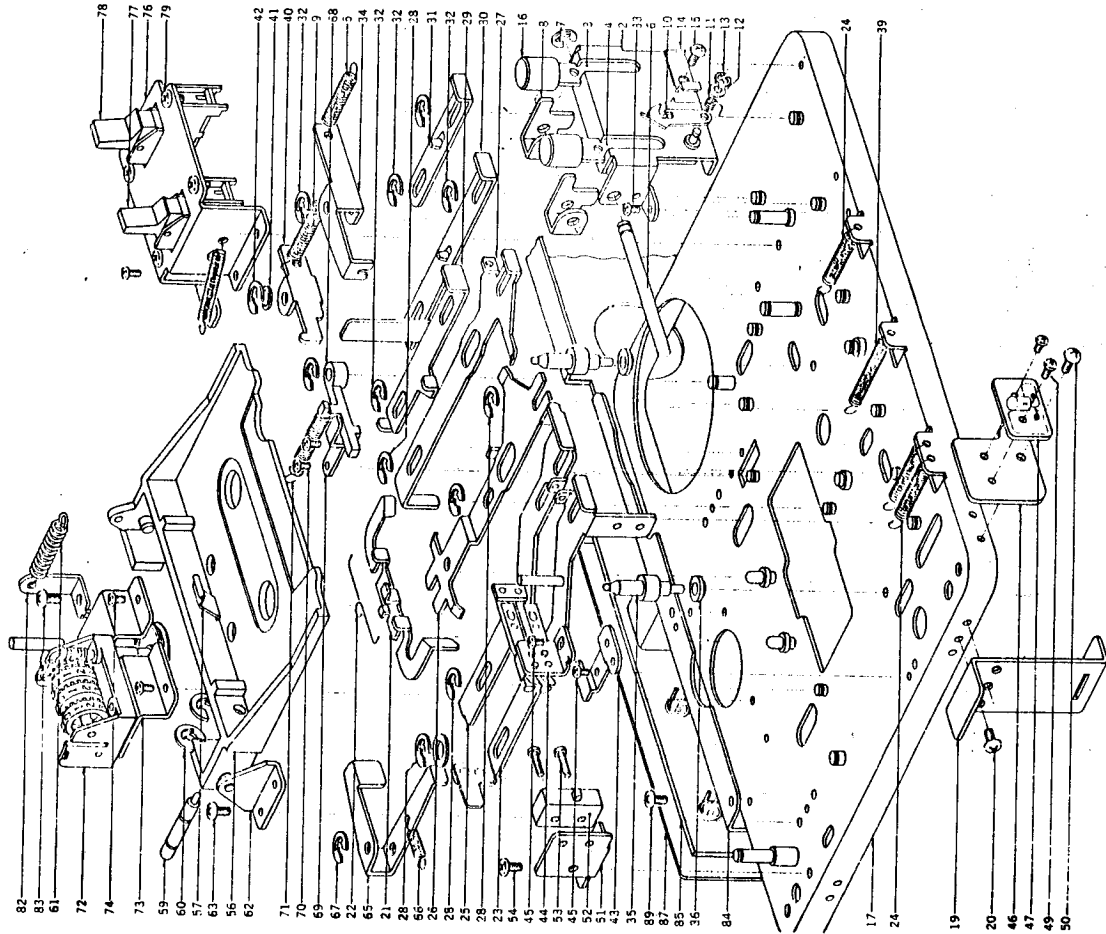

MECHANISM ASSEMBLY BLOCK (2)

Ref. No.	Parts No.	Description	Schematic No.	Qty
5-1x		OPERATION BUTTON LOCK		
5-2	451710	Operation Button Block Comp. w/pin	CG	1
	457402	Operation Button Holder	CG-200	1
		Operation Button A	CG-200	1
5-3	457413	Operation Button B w/pin	CG-200	1
5-4	461406	Operation Button B w/pin	CG-200	1
5-5	245294	Spring, Brake	RU-138	1
5-6	457435	Button Shaft	CG-200	1
5-7	290283	"U" Ring 2.85M	6-1-1	2
5-8	457424	Button Lever	CG-206	2
5-9	375262	Spring, Gear-off Lever	10R-300	1
5-10	387990	Switch, Gear-off Lever	CS-204	1
5-11	388034	Button Lock Spring	CS-204	1
5-12	290223	Operation Button Lock Washer	CS-207	1
5-13	403085	E. Ring 1.9M	6-1-9	1
5-14	403075	Pause Lock Supporting Plate	CS-215	1
5-15	447772	Tapping Screw #2 3x6 (BR)	CG-1022	2
5-16	461417	Knob B		
<b>MECH. FRAME BLOCK</b>				
5-17	456480	Mech. Frame, w/shaft	CG-1001	1
5-18x	457277	P.C. Board Retaining Plate (1)	CG-1011	2
5-19	457288	P.C. Board Retaining Plate (2)	CG-1011	2
5-20	447772	Tapping Screw #2 3x6 (BR)	CG-103	8
5-21	456928	Brake Shoe	CG-109	1
5-22	456930	Brake Spring	CG-100	1
5-23	457018	Rec. Slide w/pin, plate	CG-109	1
5-24	456136	Lock Lever Spring	CG-119	3
5-25	456963	Rewind Slide	CG-104	1
5-26	456963	Brake Slide	CG-104	1
5-27	456951	Forward Slide	CG-102	1
5-28	290283	"U" Ring 2.85M	6-1-1	8
5-29	457108	Eject Slide (1)	CG-109	1
5-30	457097	Pause Slide	CG-108	1
5-31	457121	Eject Slide (1)	CG-101	1
5-32	290283	"U" Ring 2.85M	6-1-1	7
5-33	417273	Screw, binding head 2.3x4	CG-102	2
5-34	457132	Eject Lever	CG-107	2
5-35	457198	Cassette Guide	CG-107	2
5-36	457187	Slide Collar	CG-107	2
5-37	272745	M3 Spring Washer		
5-38x	308976	M3 Nut		
5-39	308976	Node Spring	RC-387	2
5-40	457110	Washer (Nylon) 4.1x7x0.5T	CG-100	1
5-41	290283	"U" Ring 2.85M	6-1-1	1
5-42	290283	"U" Ring 2.85M	6-1-1	1
5-43	457086	Switch Table	CG-104	1
5-44	457086	Leaf Switch 2SB-2B-14	CG-104	1
5-45	417373	Screw, binding head 2.3x4	CG-103	2
5-46	457165	Rec. Lamp Table	CG-103	2
5-47	457176	Lamp P.C. Board	CG-300	1
5-48x	390576	Pilot Lamp RM6-24V-50MA	2B-2-4	1
5-49	417273	Screw, binding head 2.3x4	CG-103	2
5-50	447772	Tapping Screw #2 3x6 (BR)	CG-102	1
5-51	457075	Switch Plate	CG-102	1
5-52	389700	Micro Switch SS-5	25-1-9	1
5-53	461261	Screw, binding head 2.3x8	CG-102	1
5-54	447772	Tapping Screw #2 3x6 (BR)	CG-102	1
5-55x	461463	Cassette Sub Assembly Block	IS P.	1
5-56	457233	Cassette Base	CG-107	1
5-57	457244	Cassette Retaining Spring	CG-107	1
5-58x	447772	Tapping Screw #2 3x6 (BR)	CG-103	1
5-59	457255	Rec. Safety Pin	CG-105	2
5-60	290283	"U" Ring 2.85M	6-1-1	2
5-61	367301	Click Spring	RCC-1259	1

When ordering parts, please describe Parts Number, Serial Number, and Model Number in detail.

Ref. No.	Parts No.	Description	Schematic No.	Q'ty
5-62	457200	Cassette Base Bracket, w/pin	CG-1063	2
5-63	447772	Tapping Screw #2 3x6 (BR)		2
5-64x	273778	M3 Earth Lug		1
5-65	457064	Rec. Safety Lever (2)	CG-1057	1
5-66	385413	Auto Stop Spring B	CS-1033	1
5-67	290283	"U" Ring 2.85M	6-1-1	2
5-68	457143	Hook Lever (1)	CG-1066	1
5-69	457154	Hook Lever Holder	CG-1067	1
5-70	417273	Screw, binding head 2.3x4		2
5-71	392804	Spring, Auto Change Lever E		
		Return	CS-2566	1
5-72	453352	Counter MP-390-64, w/base	6-1-19	1
5-73	456906	Counter Base	CG-1036	1
5-74	417273	Screw, binding head 2.3x4		2
5-75x	459977	Switch Table (A) Block Comp.	CG	1
5-76	452834	Switch Table A	CG-5018	1
5-77	453418	Limiter Switch LSL242B4E	25-3-57	1
5-78	453407	Special Switch LSL262B4	25-3-56	1
5-79	371856	ISO Screw, binding head 3x5		4
5-80x	373318	Nylon Clip HP-3N		1
5-81x	447772	Tapping Screw #2 3x6 (BR)		1
5-82	457266	Spring Hook	CG-1077	1
5-83	447772	Tapping Screw #2 3x6 (BR)		1
5-84	452935	Power Supply Bracket	CG-5012	1
5-85	453475	Jack Plate A (A)	CG-5019	1
5-86x	453464	Jack Plate B (Deck)	CG-5020	1
5-87	461158	Jack Name Plate A	CS-5020	1
5-88x	461160	Jack Name Plate D (Deck)	CS-5022	1
5-89	323728	Screw, binding head 3x5		2
5-90x	453374	Keyboard Switch Comp.	25-5-51	1

### AMP. CHASSIS BLOCK

Ref. No.	Parts No.	Description	Schematic No.	Q'ty
6-1	452790	Amp. Chassis	CG-5001	1
6-2	453396	Slide Volume LD14A 50KA		
		L=20mm	36-16-3	2
6-3	453420	Slide Volume MD14A003		
		100KBx2	36-27-1	1
6-4	371856	ISO Screw, binding head 3x5		6
6-5	452856	P.C. Board Retaining Plate (3)	CG-5005	1
6-6	453431	Electrolytic Capacitor 2200μF		
		35WV	24-10-70	1
6-7	447772	Tapping Screw #2 3x6 (BR)		4
6-8	460495	Earth Spring	CG-5025	1
6-9	457277	P.C. Board Retaining Plate (1)	CG-1014	2
6-10	323728	Screw, binding head 3x5		4
6-11x	452823	Power Switch Comp.	CG-1082	1
6-12	246025	Push Switch UEH-12BP UL	25-5-11	1
6-13	376413	Spark Quencher UL		
		0.033μ+120 500WV	41-1-37	1
6-14	457446	Knob (Power) w/bush	CG-2007, 8	1
6-15	371856	ISO Screw, binding head 3x5		2
6-16x	452812	Mic Jack Comp.	CG-5021	1
6-17	452801	Jack Bracket	CG-5007	1
6-18	315281	Mic Jack 2PMJ1	31-2-19	2
6-19	225101	Jack Fiber 0.5t	DX-510	2
6-20	225180	Nylon Collar, Jack	LD-520	2
6-21	454770	Mic Jack 3PMJ1T (A)	31-2-41	1
6-22x	376604	Mic Jack 3PMJ1 (D)	31-2-17	1
6-23	376481	Washer, Jack 9.1x11.7x0.25t	DX-509	1
6-24	391680	E Jack Nut	7-1-20	3
6-25x	324641	Carbon Resistor RD1/4 1K J	R2.5	2
6-26	323728	Screw, binding head 3x5		2
6-27	452878	Mic Jack Shield	CG-5004	1
6-28	417273	Screw, binding head 2.3x4		2
6-29x	452902	Trans. Base (D)	CG-5015	1
6-30x	461430	Power Transformer CGT-3 (D)	38-4-132	1
6-31	323728	Screw, binding head 3x5		2
6-32x	457176	Lamp P.C. Board	CG-5003	1
6-33x	295312	No. 2 Lamp 8V 0.2A	28-2-8	1
6-34x	417273	Screw, binding head 2.3x4		2
6-35x	452845	Meter Cushion	CG-5002	1
6-36x	453688	VU Meter B0391R	46-1-51	2
6-37	452935	Power Supply Bracket	CG-5012	1
6-38	453453	Power Transformer CGT-1 (A)	38-4-131	1
6-39	468112	Tapping Screw #2 4x8 (truss)		4
6-40	470452	Trans. Mounting Plate	CG-5028	2
6-41	452913	Switch Bracket	CG-5014	1
6-42	375478	Slide Switch ESD-279DU	25-3-23	1
6-43x	379405	ISO Screw, binding head 3x6		2
6-44	323728	Screw, binding head 3x5		2

FIG. 6 ILLUSTRATION OF AMP. CHASIS BLOCK

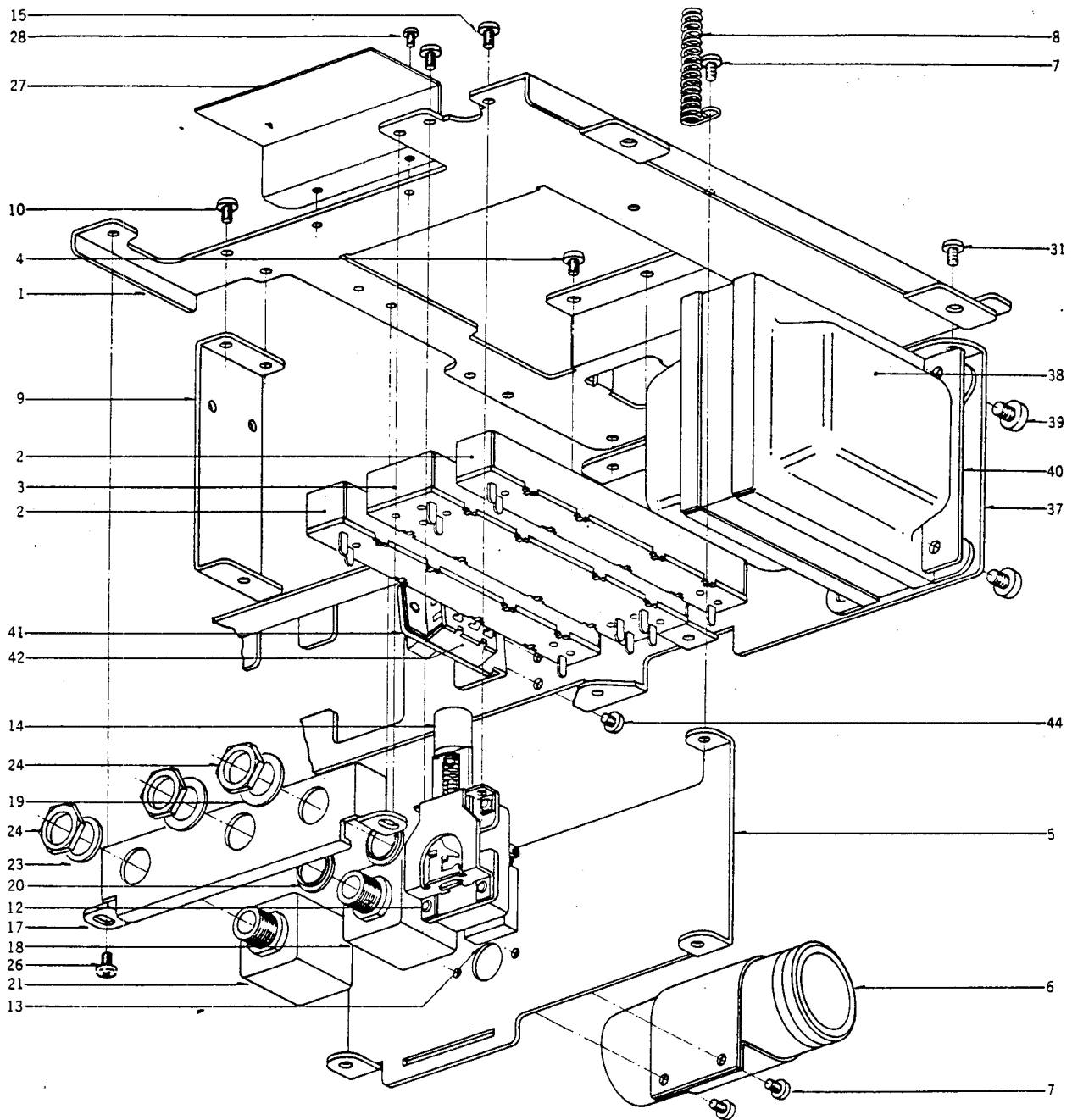
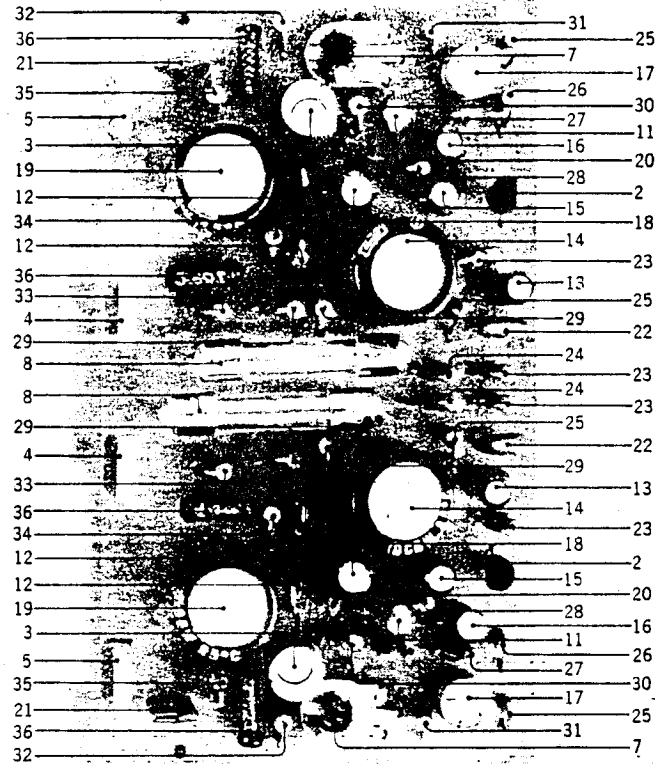

FIG. 7 PHOTO OF MAIN AMP. P.C. BOARD (CG-5009)



MAIN AMP. P.C. BOARD BLOCK (CG-5009)

Ref. No.	Parts No.	Description	Schematic No.	Q'ty	Ref. No.	Parts No.	Description	Schematic No.	Q'ty
7-1x	451732	Main Amp. P.C. Board Comp.	CG-5009	1	<b>Resistor, Stopper Type</b>				
7-2	398845	Transistor 2SC871 (E,F)	TR1	2	7-23	211757	Carbon RD 1/4 100K (J)	1, 2	4
7-3	304255	Transistor 2SC971 (2,3) (Red)	TR2	2	7-24	212477	Carbon RD 1/4 3.3K (J)	3	2
7-4	465208	Transistor 2SC1098 (L,K)	TR3	2	7-25	211465	Carbon RD 1/4 1K (J)	4, 6	4
7-5	465265	Transistor 2SA636 (L,K)	TR4	2	7-26	211667	Carbon RD 1/4 100 (J)	5	2
7-6	323728	Screw, binding head 3x5		2	7-27	349942	Carbon RD 1/4 8.2K (J)	7	2
7-7	329152	Semi-Variable Volume V10K5-2-4 30KB	VR1	2	7-28	357456	Carbon RD 1/4 2.2K (J)	8	2
7-8	453666	Fuse ST-3 0.7A	F1	2	7-29	349784	Carbon RD 1/4 390 (J)	9, 12	4
7-9x	452992	Heat-Sink Plate	CG-5008	1	7-30	357535	Carbon RD 1/4 39K (J)	10	2
7-10x	417227	Screw, binding head 2.3x5		2	7-31	306360	Carbon RD 1/4 6.8K (J)	11	2
7-11	453655	Thermister 42D26	TH1	2	7-32	304290	Carbon RD 1/4 10 (J)	13	2
7-12	453644	Varistor RV	V1.2	4	7-33	361642	Carbon RD 1/4 47 (J)	14	2
		<b>Capacitor, Vertical Type</b>			7-34	347038	Carbon RD 1/4 270 (J)	15	2
7-13	350706	Electrolytic 4.7μF 16WV		2	7-35	399723	Carbon RD 1/4 4.7 (J)	18	2
7-14	372148	Electrolytic 220μF 35WV		2	7-36	453677	Wire Wind (L Type) 1/2WL 0.5 (J)	16, 17	4
7-15	320051	Electrolytic 10μF 16WV		2					
7-16	331828	Electrolytic 3.3μF 25WV		2					
7-17	220364	Electrolytic 100μF 6.3WV		2					
7-18	331705	Electrolytic 22μF 16WV		2					
7-19	331817	Electrolytic 470μF 25WV		2					
7-20	350875	Mylar 0.001μF (J) 50WV		2					
7-21	379214	Mylar 0.047μF (J) 50WV		2					
7-22	290520	VFM 100PF (J) 50WV		2					

When ordering parts, Please describe Parts Number, Serial Number, and Model Number in detail.



FIG. 8 PHOTO OF PRE-AMP. P.C. BOARD (CG-5010)

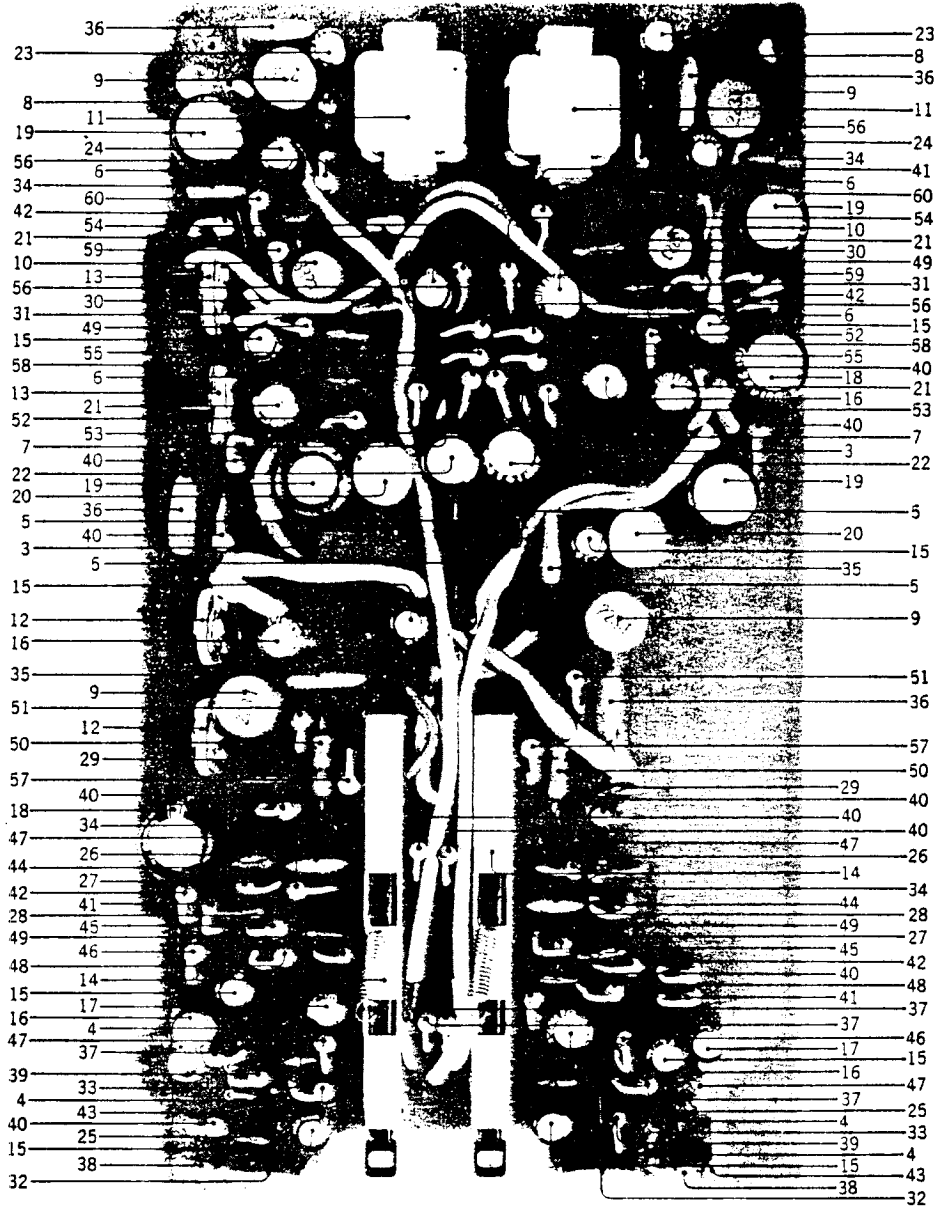

**PRE-AMP. P.C. BOARD (CG-5010) BLOCK**

Ref. No.	Parts No.	Description	Schematic No.	Q'ty
8-1x	461351	Pre-Amp. P.C. Board Comp. (A)	CG-5010	1
8-2x	461362	Pre-Amp. P.C. Board Comp. (D)	CG-5010	1
8-3	412413	Line Amp. I.C. LD-3141	IC1	2
8-4	234854	Transistor 2SC458LG (C)	TR1, 2	4
8-5	398711	Transistor 2SC945 (Q,R)	TR3, 4	4
8-6	453486	Transistor 2SC711 (E,F)	TR5, 6	4
8-7	224526	Silicon Diode 10D1	D1	2
8-8	417442	Germanium Diode 1N34A	D2	1
8-9	244012	Ferri Inductor FL9H 22MH (J)	L1, J	4
8-10	243988	Ferri Inductor FL7H 3.3MH (J)	L2	2
8-11	247746	Head Phone Transformer N19-228S	T1	2
8-12	426936	Semi-Variable Volume V10K-5 30K B	VR1	2
8-13	221848	Semi-Variable Volume V10K-5 2KB	VR2	2
8-14	446196	Slide Switch CL192A2	SW1	2
<b>Capacitor, Vertical Type</b>				C
8-15	320051	Electrolytic 10μF 16WV	2, 10, 14, 24, 31	10
8-16	329771	Electrolytic 47μF 6.3WV	4, 16	4
8-17	220432	Electrolytic 2.2μF 25WV	11	2
8-18	220151	Electrolytic 100μF 25WV	12	2
8-19	220678	Electrolytic 47μF 25WV	17, 25	4
8-20	220364	Electrolytic 100μF 6.3WV	18	2
8-21	220994	Electrolytic 10μF 25WV	19, 21	4
8-22	320040	Electrolytic 47μF 16WV	20	2
8-23	450055	Electrolytic 1μF 25WV	23	2
8-24	450527	Electrolytic 4.7μF 25WV	28	2
8-25	250875	Mylar 0.001μF (J) 50WV	3	2
8-26	379192	Mylar 0.039μF (J) 50WV	5	2
8-27	389485	Mylar 0.018μF (J) 50WV	6	2
8-28	424708	Mylar 0.0018μF (J) 50WV	9	2
8-29	329883	Mylar 0.0056μF (J) 50WV	22 (A)	2
8-30	329861	Mylar 0.027μF (J) 50WV	26	2
8-31	411827	Mylar 0.0082μF (J) 50WV	27	2
8-32	350717	VFM 390PF (J) 50WV	1	2
8-33	399565	VFM 22PF (J) 50WV	7	2
8-34	290520	VFM 100PF (J) 50WV	8, 29	4
8-35	336216	VFM 330PF (J) 50WV	13	2
8-36	336194	VFM 270PF (J) 50WV	15, 30	4
<b>Resistor, Stopper Type</b>				R
8-37	212883	Carbon RD 1/4 4.7K (J)	1, 11	4
8-38	211858	Carbon RD 1/4 12K (J)	2	2
8-39	357590	Carbon RD 1/4 150K (J)	3	2
8-40	336442	Carbon RD 1/4 10K (J)	4, 16, 17, 28, 34	10
8-41	211465	Carbon RD 1/4 1K (J)	5, 31	4
8-42	357412	Carbon RD 1/4 220 (J)	6, 33	4
8-43	465276	Carbon RD 1/4 270K (J)	7	2
8-44	212174	Carbon RD 1/4 180K (J)	8	2
8-45	391961	Carbon RD 1/4 91K (J)	9	2
8-46	343078	Carbon RD 1/4 2.7K (J)	10	2
8-47	212264	Carbon RD 1/4 22K (J)	12, 13	4
8-48	349942	Carbon RD 1/4 8.2K (J)	14	2
8-49	306360	Carbon RD 1/4 6.8K (J)	15, 29	4
8-50	214290	Carbon RD 1/4 4.7K (J) (Insulator)	18	2
8-51	361528	Carbon RD 1/4 56K (J)	19	2
8-52	342933	Carbon RD 1/4 27K (J)	20	2
8-53	213030	Carbon RD 1/4 5.6K (J)	21	2
8-54	211320	Carbon RD 1/4 1.5K (J)	22, 36	4
8-55	212477	Carbon RD 1/4 3.3K (J)	23	2
8-56	357456	Carbon RD 1/4 2.2K (J)	24, 27	4
8-57	349907	Carbon RD 1/4 33K (J)	25	2
8-58	419040	Carbon RD 1/4 1M (J)	26	2
8-59	211757	Carbon RD 1/4 100K (J)	30	2
8-60	306887	Carbon RD 1/4 15K (J)	32	2
8-61x	304290	Carbon RD 1/4 10 (J)	35 (B)	2

**FIG. 9 PHOTO OF POWER SUPPLY & OSC. P.C. BOARD (CG-5011)**

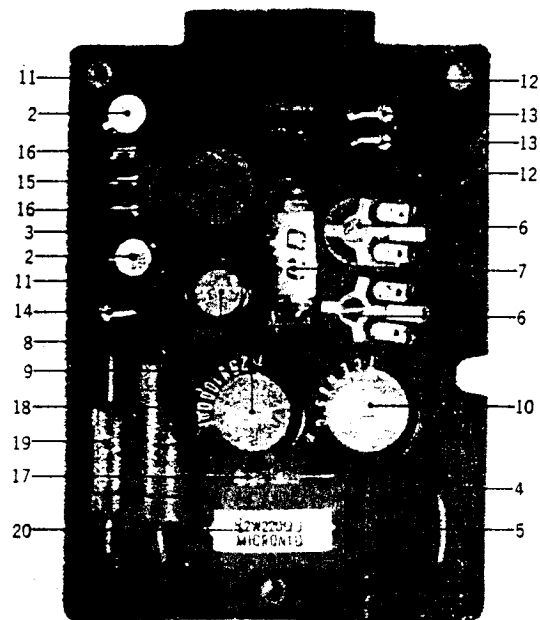

**POWER SUPPLY & OSC. P.C. BOARD (CG-5011) BLOCK**

Ref. No.	Parts No.	Description	Schematic No.	Q'ty
9-1x	451721	Power Supply & OSC. P.C. Board Comp.	CG-5011	1
9-2	453690	Transistor 2SC968 (2,3) (Red)	TR1, 2	2
9-3	453521	Oscillator Coil OT-803	L1	1
9-4	329130	Silicon Diode 10DC-1 (Black)	D1	1
9-5	329128	Silicon Diode 10DC-1 (Red)	D2	1
9-6	465221	Semi-Variable Volume V10K5-2-8 500K B	VR1, 2	2
9-7	460091	Plastic Film Condenser 3.3K PF (J)	C3	1
<b>Capacitor, Vertical Type</b>				C
9-8	220151	Electrolytic 100μF 25WV	4	1
9-9	450270	Electrolytic 1KμF 25WV	7	1
9-10	444082	Electrolytic 470μF 35WV	8	1
9-11	250841	Mylar 0.01μF (J) 50WV	5, 6	2
9-12	290520	VFM 100PF (J) 50WV	1, 2	2
<b>Resistor, Stopper Type</b>				R
9-13	349907	Carbon RD 1/4 33K (J)	1, 2	2
9-14	212883	Carbon RD 1/4 4.7K (J)	3	1
9-15	304402	Carbon RD 1/4 470 (J)	4	1
9-16	315944	Carbon RD 1/4 3.3 (J)	5, 6	2
9-17	453576	Carbon RD 1/2 330 (J) (Insulator)	10	1
9-18	461968	Metal Oxide Film Resistor 3W 420 (J)	7	1
9-19	453565	Metal Oxide Film Resistor 2W 1.2K (J)	8	1
9-20	467245	Cement Resistor (Metal Oxide Film Type) B2W 220 K	9	1

FIG. 10 PHOTO OF POWER & JACK PLATE BLOCK

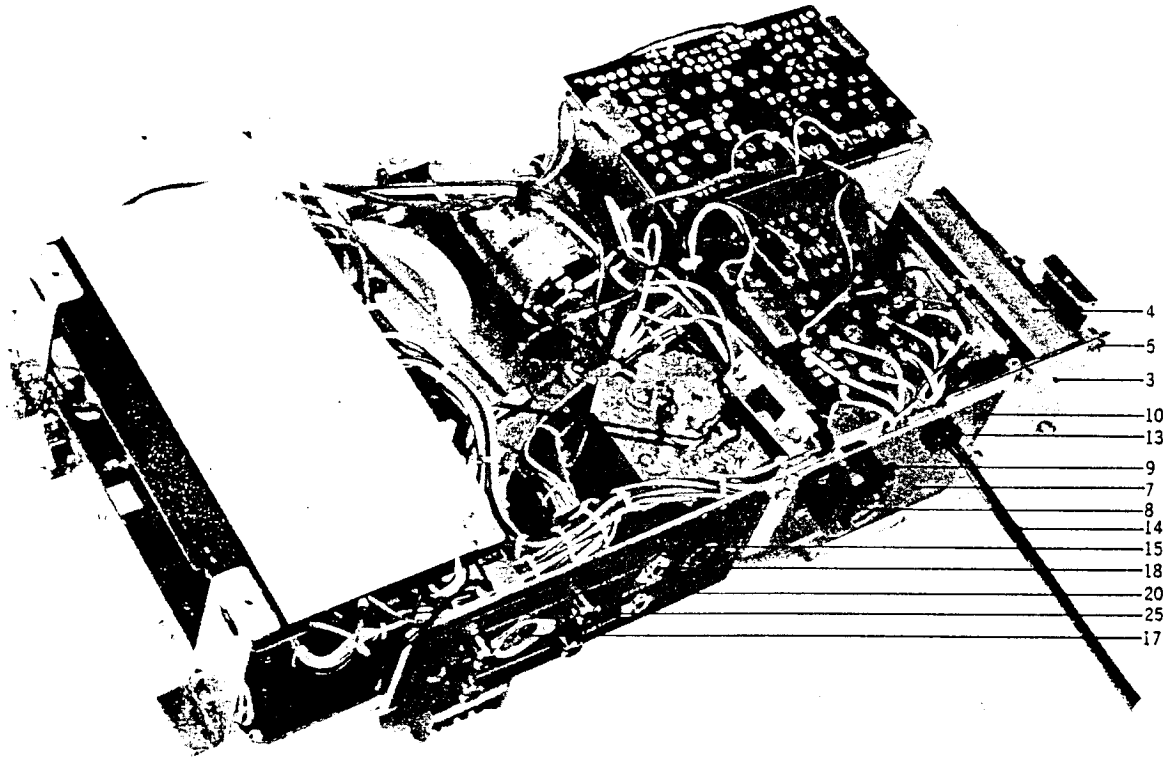

POWER & JACK PLATE BLOCK

Ref. No.	Parts No.	Description	Schematic No.	Q'ty
10-1x	461136	Power & Jack Plate Block Comp. (A)	CGA	1
10-2x	461147	Power & Jack Plate Block Comp. (D)	CGD	1
10-3	452935	Power Supply Bracket	CG-5012	1
10-4	453453	Power Transformer CGT-1 (A)	38-4-131	1
10-5	468112	Tapping Screw #2 4x8 (truss)		4
10-6x	470452	Trans. Retaining Plate	CG-5028	2
10-7	452924	Power Name Plate	CG-5013	1
10-8	233370	Power Plug Socket (Volt. Select.) S-18010	40-2-3	1
10-9	372025	ISO Screw, truss head 3x6 (Black)		2
10-10	201150	Screw, truss head 3x6 (Black)		1
10-11x	277402	Fuse ST-2 1A (A)	39-1-26	1
10-12x	371698	Fuse ST-4 0.5A (D)	39-1-28	1
10-13	382263	Strain Relief SR-4K-4	2-7-12	1
10-14	374894	U/L AC Cord 3M	26-3-19	1
10-15	453475	Jack Plate A (A)	CG-5019	1
10-16x	453464	Jack Plate B (D)	CG-5020	1
10-17	299305	5P DIN Jack	31-1-1	1
10-18	328364	Mic Jack 2PMJ3	31-2-20	2
10-19x	376481	Jack Thin Washer 9.1x11.7x0.25t	DX-509	2
10-20	375153	E Jack Nut		2
10-21x	255093	Lug Plate VB1L1	33-4-1	1
10-22x	345712	Carbon Resistor RD 1/4 22K J	R3, 4, 7, 10	4
10-23x	213647	Carbon Resistor RD 1/4 10K J	R8, 9	2
10-24x	365016	Carbon Resistor RD 1/4 220K J	R1, 6	2
10-25	461158	Jack Name Plate A	CS-5020	1
10-26x	461160	Jack Name Plate D	CS-5022	1

When ordering parts, Please describe Parts Number, Serial Number, and Model Number in detail.

FIG. 11 (A) PHOTO OF FINAL ASSEMBLY BLOCK

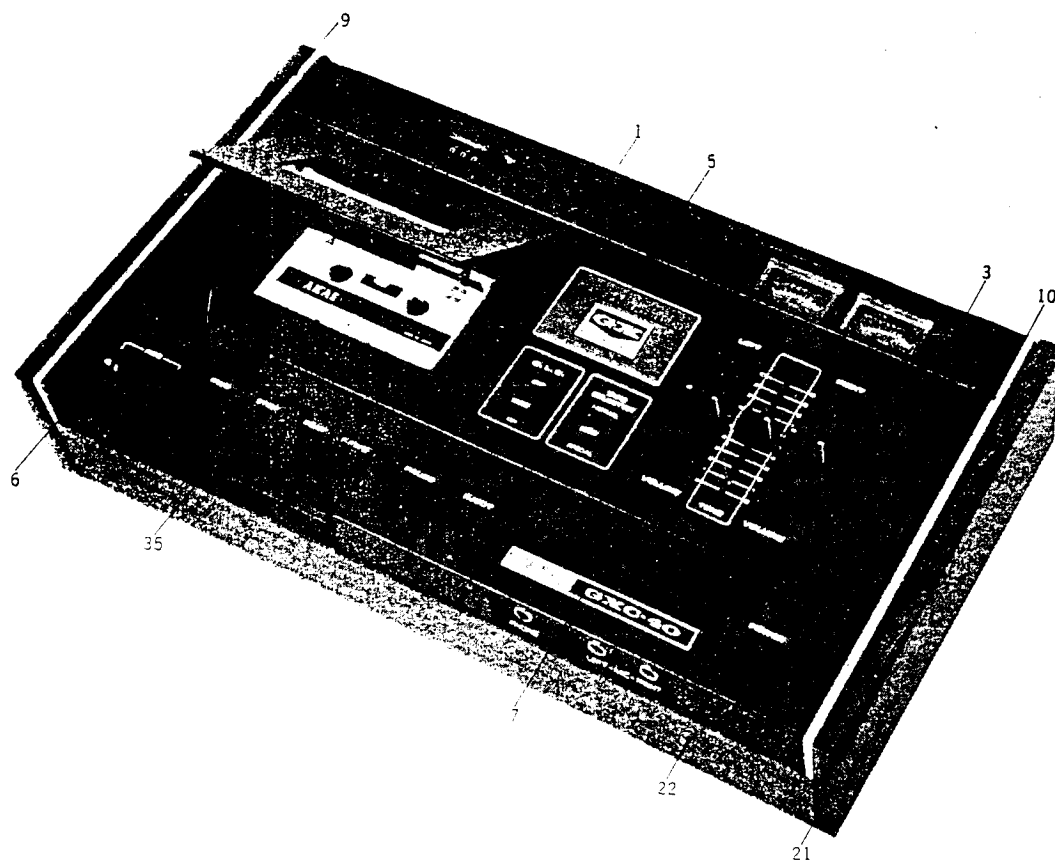
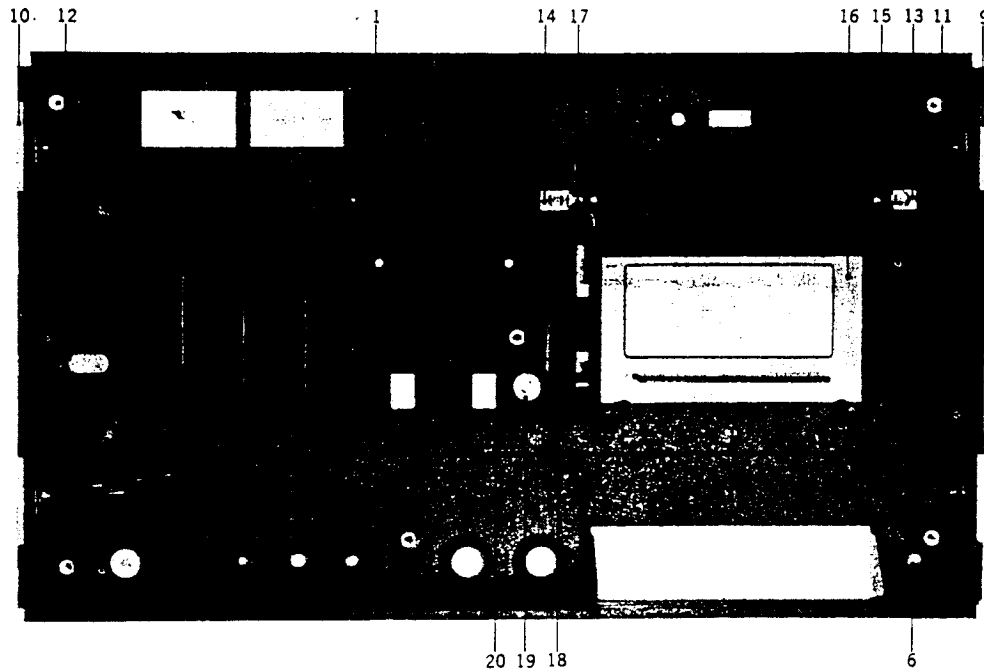

FIG. 11 (B) PHOTO OF FINAL ASSEMBLY BLOCK



**FINAL ASSEMBLY BLOCK**

Ref. No.	Parts No.	Description	Schematic No.	Q'ty
<b>CASE BLOCK</b>				
11-1	453003	Upper Case A Comp.	CG-6001, 34	1
11-2x	451618	Upper Case B Comp. (Deck)	CG-6001, 35	1
11-3	453047	Case Plate (1)	CG-6005, 28	1
11-4x	453058	Case Plate (2) (Deck)	CG-6005, 29	1
11-5	453150	GX Name Plate	CG-6015	1
11-6	426780	Illumination Lamp Escutcheon (Red)	61-5023	1
11-7	453161	Name Plate (GXC-40)	CG-6016	1
11-8x	453172	Name Plate (GXC-40D)	CG-6017	1
11-9	453183	Sash (1) (Right)	CG-6018	1
11-10	453194	Sash (2) (Left)	CG-6018	1
11-11	425103	Screw, countersunk head 3x10		4
11-12	469350	Speed Nut M3 (F Type)		4
11-13	453082	Lid Bracket, w/pin (1)	CG-6008, 9	1
11-14	453104	Lid Bracket, w/pin (2)	CG-6008, 10	1
11-15	323728	Screw, binding head 3x5		2
11-16	453126	Case Lid	CG-6014	1
11-17	453115	Lid Spring	CG-6013	1
11-18	453060	Hook Lever (2)	CG-6007	1
11-19	290283	"U" Ring 2.85M	6-1-1	1
11-20	469372	Lid Spring B	CG-6053	1
11-21	453205	Wood Frame	CG-6019	1
11-22	453240	Case Lower Comp.	CG-6037	1
11-23x	453262	Cover (Cycle)	CG-6021	1
11-24x	461305	Screw, countersunk head 3x5 (Black)		1
11-25x	453227	CG Rubber Foot	CG-6024	4
<b>ASSEMBLY BLOCK</b>				
11-26x	417025	Screw, binding head 3x4 w/washer		6
11-27x	201183	Screw, truss head 3x8 (Black)		6
11-28	453238	Volume Knob	CG-6027	3
11-29x	463195	Knob Stopper	CG-6049	3
11-30x	371698	Fuse ST-4 0.5 A (A)	29-1-28	1
11-31x	277402	Fuse ST-2 1A (A)	39-1-26	1
11-32x	395897	Fuse ST-4 0.25 A (D)	39-1-28	1
11-33x	453273	Rear Name Plate (GXC-40)	CG-6025	1
11-34x	453284	Rear Name Plate (GXC-40D)	CG-6026	1
11-35	453374	Keyboard Switch Comp.	25-5-51	1

When ordering parts, Please describe Parts Number, Serial Number, and Model Number in detail.

FIG. 12 ILLUSTRATION OF KEYBOARD SWITCH BLOCK

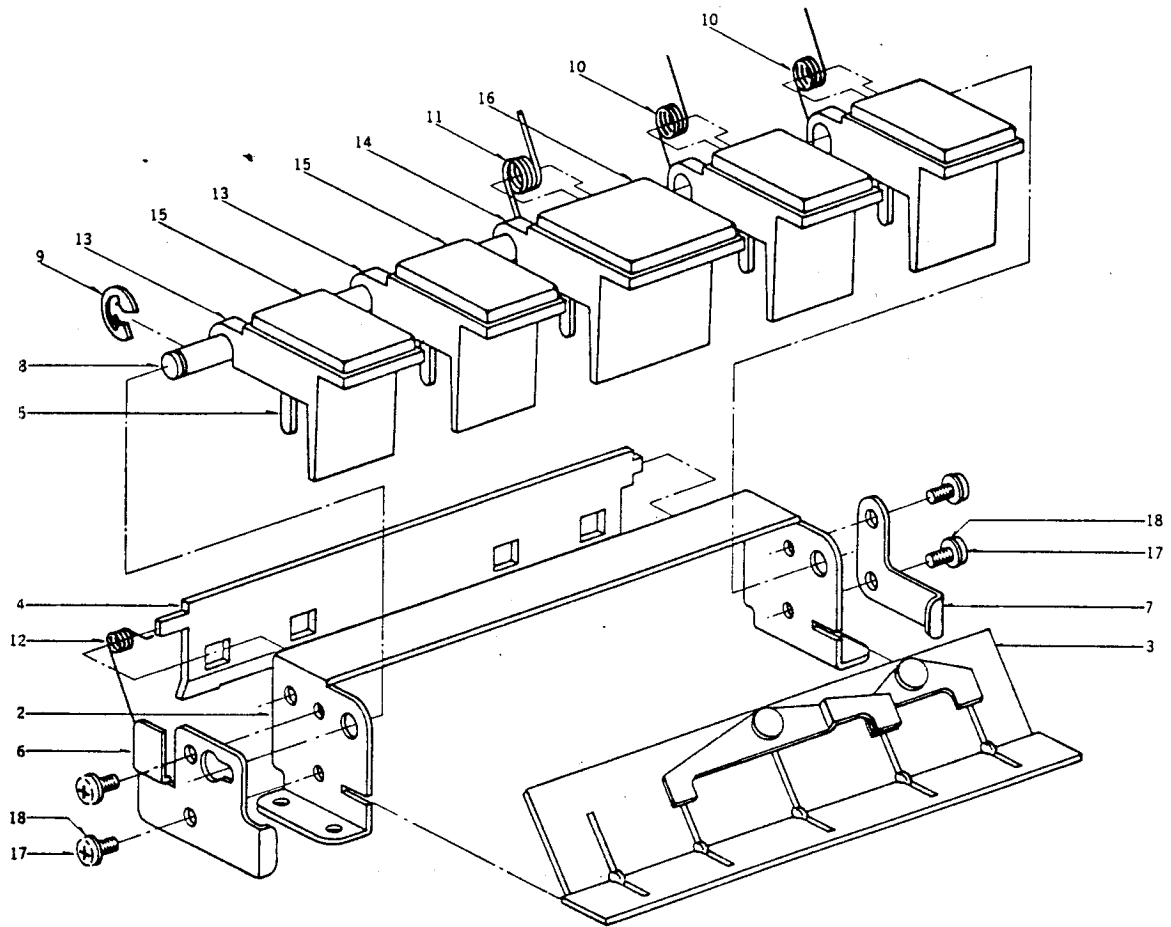

KEYBOARD SWITCH BLOCK

Ref. No.	Parts No.	Description	Maker No.	Q'ty
12-1x	453374	Keyboard Switch Comp.	25-5-51	1
12-2	CG-K01	Keyboard Holder	ME1-0105	1
12-3	CG-K02	Keyboard Lever Guide, w/lever (1,2)	ME1-0205	1
12-4	CG-K03	Keyboard Lock Plate	ME3-0105	1
12-5	CG-K04	Keyboard Lever	ME2-0100	5
12-6	CG-K05	Guide Bracket (1)	ME1-1010	1
12-7	CG-K06	Guide Bracket (2)	ME1-1020	1
12-8	CG-K07	Keyboard Shaft	ME2-4100	1
12-9	CG-K08	Slide Pin (3)	ME4-4100	2
12-10	CG-K09	Keyboard Spring (A)	ME2-2110	4
12-11	CG-K10	Keyboard Spring (B)	ME2-2120	1
12-12	CG-K11	Lock Plate Spring	ME3-2100	1
12-13	CG-K12	Keyboard (1)	ME2-6110	4
12-14	CG-K13	Keyboard (2)	ME2-6120	1
12-15	CG-K14	Keyboard Cover (1)	ME2-0510	4
12-16	CG-K15	Keyboard Cover (2)	ME2-0520	1
12-17	CG-K16	Screw, pan head 3x6	P30-N06F	4
12-18	CG-K17	Spring Washer 3M	W30-SOP1	4

# INDEX

Parts No.	Ref. No.	Parts No.	Ref. No.	Parts No.	Ref. No.	Parts No.	Ref. No.	Parts No.	Ref. No.	Parts No.	Ref. No.
201150	10-10	315281	6-18	385413	5-66	447772	5-81x	456186	5-24	461261	5-53
201183	11-27x	315944	9-16	387268	2-20	447772	5-83	456480	5-17	461305	11-24x
211320	8-54	320040	8-22	387573	3-11	447772	6-7	456614	2-14	461351	8-1x
211465	7-25	320051	7-15	387584	3-13	447840	4-39	456625	2-24	461362	8-2x
211465	8-41	320051	8-15	387606	3-14	450055	8-23	456647	2-17	461395	1-18
211667	7-26	323728	5-89	387617	3-16x	450270	9-9	456660	2-18	461406	5-4
211757	7-23	323728	6-10	387630	3-15	450527	8-24	456671	2-26	461417	5-16
211757	8-59	323728	6-26	387641	3-19	451618	11-2x	456682	2-19	461430	6-30x
211858	8-38	323728	6-31	387990	5-10	451675	2-1x	456693	4-33	461463	5-55x
212174	8-44	323728	6-44	388023	5-12	451686	3-9x	456726	4-34	461586	4-14x
212264	8-47	323728	7-6x	388034	5-11	451697	3-1x	456783	4-2	461878	4-12
212477	7-24	323728	11-15	389485	8-27	451708	1-1x	456827	4-4	461880	4-13
212477	8-55	324641	6-25x	389700	5-52	451710	5-1x	456838	4-7	461891	4-15
212883	8-37	328364	10-18	389790	3-4	451721	9-1x	456840	4-8	461968	9-18
212883	9-14	329128	9-5	389981	1-5	451732	7-1x	456851	4-5x	462690	4-11x
213030	8-53	329130	9-4	390576	5-48x	451934	1-14	456862	4-6x	462881	1-12
213647	10-23x	329152	7-7	391285	4-40	451945	1-22	456895	4-22	462892	1-21x
214290	8-50	329771	8-16	391397	1-6	452790	6-1	456906	5-73	463195	11-29x
220151	8-18	329861	8-30	391397	4-20	452801	6-17	456917	3-22	465208	7-4
220151	9-8	329883	8-29	391680	6-24	452812	6-16x	456928	5-21	465221	9-6
220364	7-17	331705	7-18	391961	8-45	452823	6-11x	456930	5-22	465636	1-13
220364	8-20	331817	7-19	392804	4-3	452834	5-76	456941	5-26	465265	7-5
220432	8-17	331828	7-16	392804	5-71	452845	6-35x	456952	5-27	465276	8-43
220678	8-19	336194	8-36	393671	4-38	452856	6-5	456963	5-25	467245	9-20
220994	8-21	336216	8-35	394075	2-5	452878	6-27	456974	4-26	468112	6-39
221848	8-13	336442	8-40	394200	3-21	452902	6-29x	456985	4-27	468112	10-5
224526	8-7	342933	8-52	395897	11-32x	452913	6-41	456996	4-23	468270	2-13
224796	4-24	343078	8-46	396415	2-2	452924	10-7	457018	5-23	468292	1-4
225101	6-19	345712	10-22x	396426	2-3	452935	5-84	457042	4-44	469315	4-37
225180	6-20	347038	7-34	398711	8-5	452935	6-37	457053	4-42	469350	11-12
233370	10-8	349784	7-29	398845	7-2	452935	10-3	457064	5-65	469372	11-20
234854	8-4	349907	8-57	399071	1-25	452992	7-9x	457075	5-51	469563	2-10
243988	8-10	349907	9-13	399565	8-33	453003	11-1	457086	5-43	470452	6-40
244012	8-9	349942	7-27	399723	7-35	453047	11-3	457097	5-30	470452	10-6x
245294	5-5	349942	8-48	402322	2-11	453058	11-4x	457108	5-29		
246025	6-12	350706	7-13	403007	5-14	453060	11-18	457110	5-40	CG-K01	12-2
247746	8-11	350717	8-32	411827	8-31	453082	11-13	457121	5-31	CG-K02	12-3
250841	9-11	350875	7-20	412413	8-3	453104	11-14	457132	5-34	CG-K03	12-4
250875	8-25	355307	3-12	413155	2-16x	453115	11-17	457143	5-68	CG-K04	12-5
255093	10-21x	356804	2-8	413188	2-21	453126	11-16	457154	5-69	CG-K05	12-6
259738	4-31	357412	8-42	414235	1-15	453150	11-5	457165	5-46	CG-K06	12-7
259773	5-41	357456	7-28	414246	1-16	453161	11-7	457176	5-47	CG-K07	12-8
259795	4-17	357456	8-56	417025	2-23	453172	11-8x	457176	6-32x	CG-K08	12-9
270088	1-8	357535	7-30	417025	2-27x	453183	11-9	457187	5-36	CG-K09	12-10
270088	3-20	357590	8-39	417025	11-26x	453194	11-10	457198	5-35	CG-K10	12-11
270088	5-13	361528	8-51	417137	1-11	453205	11-21	457198	5-35	CG-K11	12-12
270101	2-4	361642	7-33	417137	4-45	453205	11-21	457200	5-62	CG-K12	12-13
270123	4-10	364342	3-3	417148	2-12	453227	11-25x	457233	5-56	CG-K13	12-14
273633	1-23x	365016	10-24x	417227	1-24	453238	11-28	457244	5-57	CG-K14	12-15
273688	1-19	366625	1-17	417227	2-25	453240	11-22	457255	5-59	CG-K15	12-16
273688	4-29	367301	5-61	417227	4-28	453262	11-23x	457266	5-82	CG-K16	12-17
273745	5-37x	370348	3-7	417227	7-10x	453273	11-33x	457277	5-18x	CG-K17	12-18
273756	5-38x	370361	3-6	417227	7-10x	453284	11-34x	457277	6-9		
273778	5-64x	370361	3-18	417251	2-15	453352	5-72	457288	5-19		
277402	10-11x	370372	3-8	417273	1-20	453363	5-44	457290	2-7		
277402	11-31x	371698	10-12x	417273	4-43	453374	4-46x	457301	2-6		
290283	4-19	371698	11-30x	417273	5-33	453374	5-90x	457312	3-2		
290283	4-25	371856	5-79	417273	5-45	453374	11-35	457312	3-10		
290283	4-30	371856	6-4	417273	5-49	453374	12-1x	457323	1-2		
290283	4-36	371856	6-15	417273	5-70	453396	6-2	457367	1-10		
290283	5-7	372025	10-9	417273	5-74	453407	5-78	457378	1-9		
290283	5-28	372148	7-14	417273	6-28	453418	5-77	457380	1-7		
290283	5-32	373318	5-80x	417273	6-34x	453420	6-3	457391	1-3		
290283	5-42	374894	10-14	417442	8-8	453431	6-6	457402	5-2		
290283	5-60	375153	10-20	419040	8-58	453453	6-38	457413	5-3		
290283	5-67	375262	5-9	420682	2-22	453453	10-4	457424	5-8		
290283	11-19	375478	6-42	421007	4-18	453464	5-86x	457435	5-6		
290520	7-22	376413	6-13	424708	8-28	453464	10-16x	457446	6-14		
290520	8-34	376481	6-23	425103	11-11	453475	5-85	459224	4-16		
290520	9-12	376481	10-19x	426780	11-6	453475	10-15	459966	4-1x		
295312	6-33x	376604	6-22x	426936	8-12	453486	8-6	459977	5-75x		
299305	10-17	379192	8-26	444082	9-10	453521	9-3	460091	9-7		
304255	7-3	379214	7-21	446196	8-14	453565	9-19	460484	4-32		
304290	7-32	379405	6-43x	447772	4-41	453576	9-17	460495	6-8		
304290	8-61x	381644	4-9x	447772	4-47x	453644	7-12	461136	10-1x		
304402	9-15	381644	4-21	447772	5-15	453655	7-11	461147	10-2x		
306360	7-31	382263	10-13	447772	5-20	453666	7-8	461158	5-87		
306360	8-49	384164	2-9	447772	5-50	453677	7-36	461158	10-25		
306887	8-60	385075	3-5	447772	5-54	453688	6-36x	461160	5-88x		
308970	5-39	385075	3-17	447772	5-58x	453690	9-2	461160	10-26x		
				447772	5-63	454770	6-21	461248	4-35		

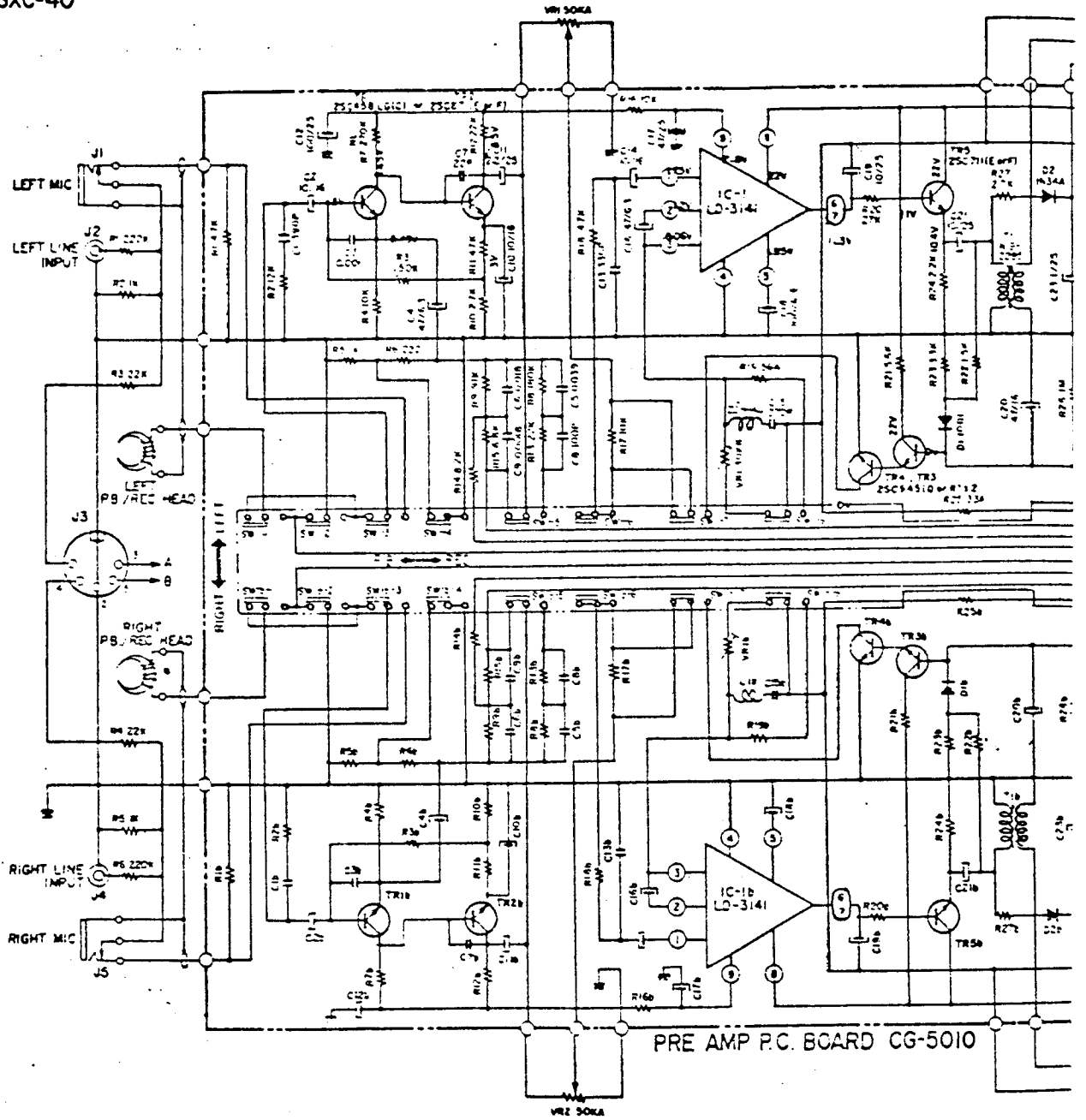

PRE AMP P.C. BOARD CG-5010

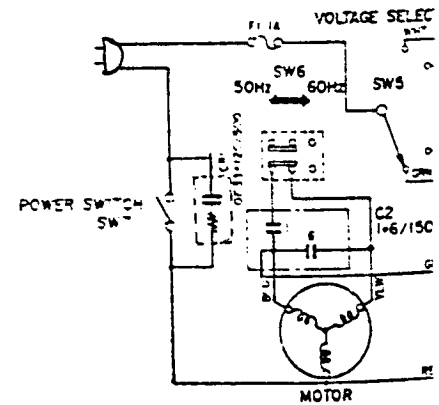

NOTE

- UNLESS OTHERWISE MARKED, RESISTOR UNITS IN Ω
- UNLESS OTHERWISE MARKED, CAP. UNITS IN 1/4W
- UNLESS OTHERWISE MARKED, CAP. TOLERANCE INDICATED BY J.
- UNLESS OTHERWISE MARKED, CAPACITOR UNITS IN µFD.
- UNLESS OTHERWISE MARKED, VOLTAGE UNITS IN 50V.
- UNLESS OTHERWISE MARKED, CAP. TOLERANCE INDICATED BY J.
- FOLLOWING C OF R. NUMBERS MEANS "RIGHT CHANNEL".





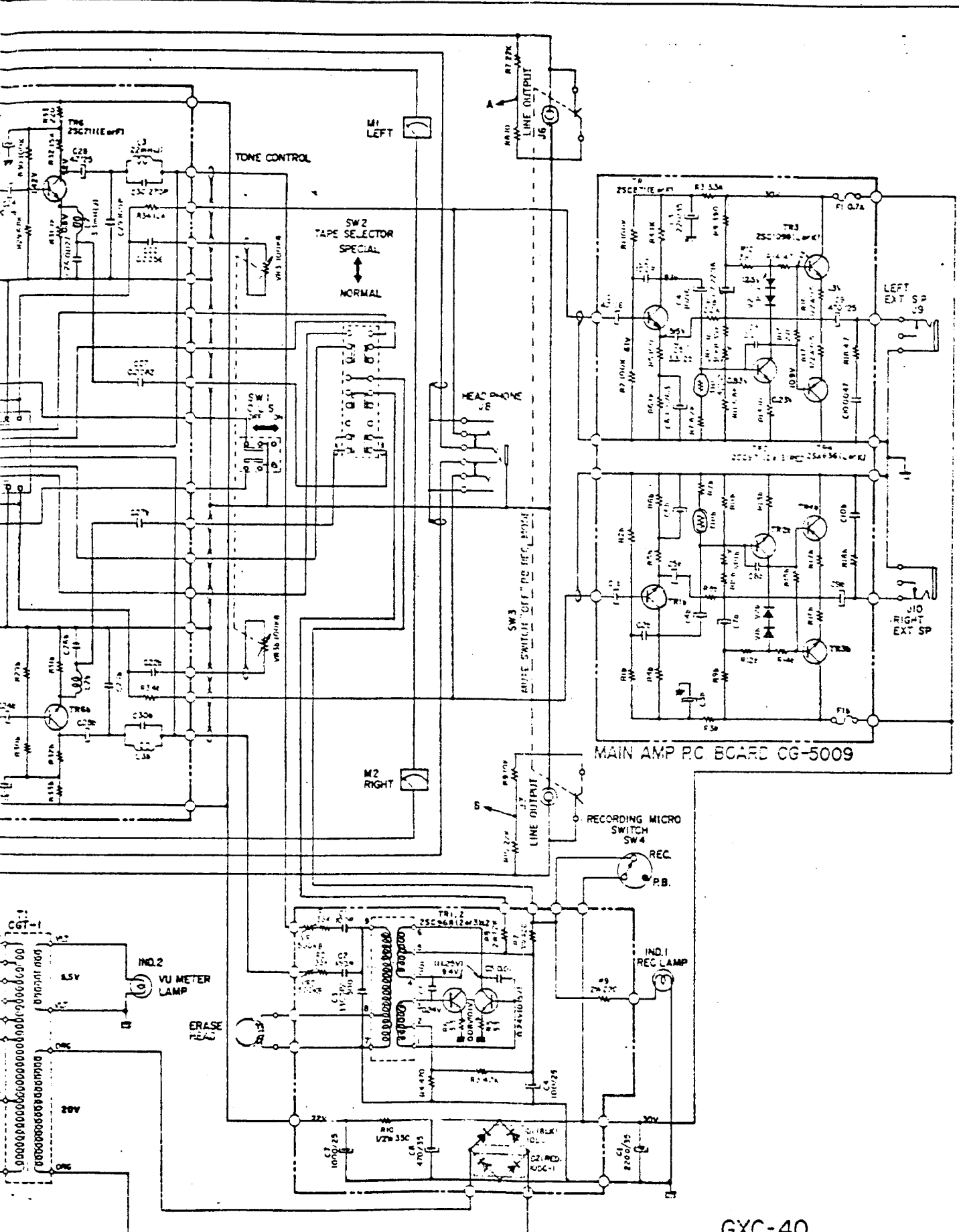

O.S.C. & POWER SUPPLY PC BOARD CG-5011

GXC-40  
SCHEMATIC DIAGRAM  
1440212A

GXC-40D

PRE AMP P.C. BOARD.  
CG-5010

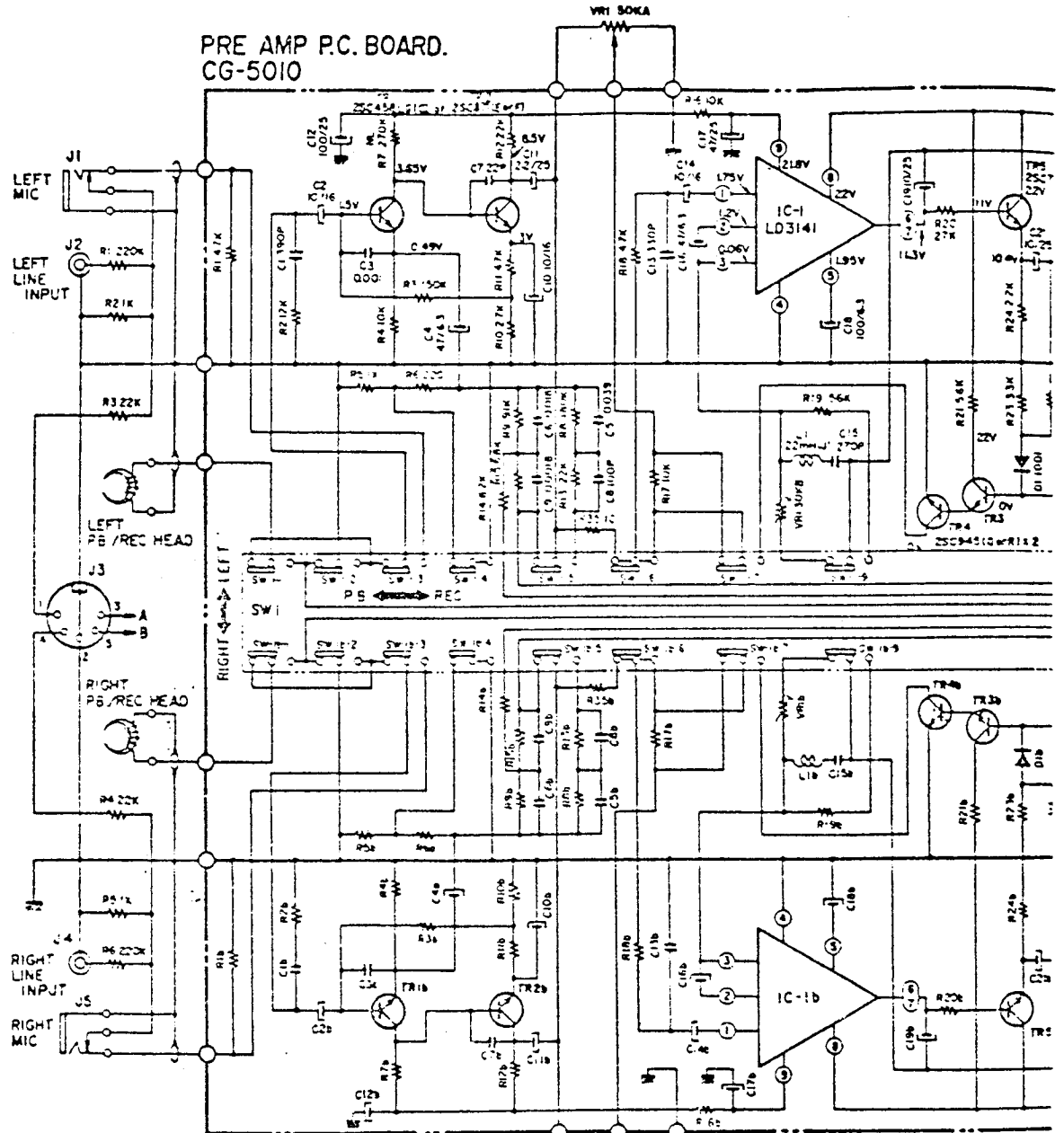

NOTE

- UNLESS OTHERWISE MARKED, RESISTOR VALUE IS IN OHMS
- UNLESS OTHERWISE MARKED, WATT VALUE IS IN WATTS
- UNLESS OTHERWISE MARKED, ERROR TOLERANCE INDICATED BY J
- UNLESS OTHERWISE MARKED, CONDENSER VALUE IS IN P.F.
- UNLESS OTHERWISE MARKED, VOLTAGE VALUE IS IN VOLTS
- UNLESS OTHERWISE MARKED, ERROR TOLERANCE INDICATED BY J
- R, P, C, OR N, C, OR R NUMBERS MEANS "RIGHT CHANNEL"

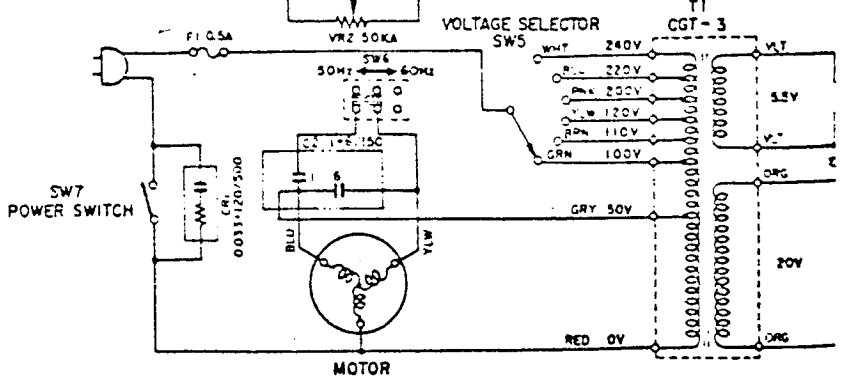

PRE AMP P.C. BOARD.  
CG-5010

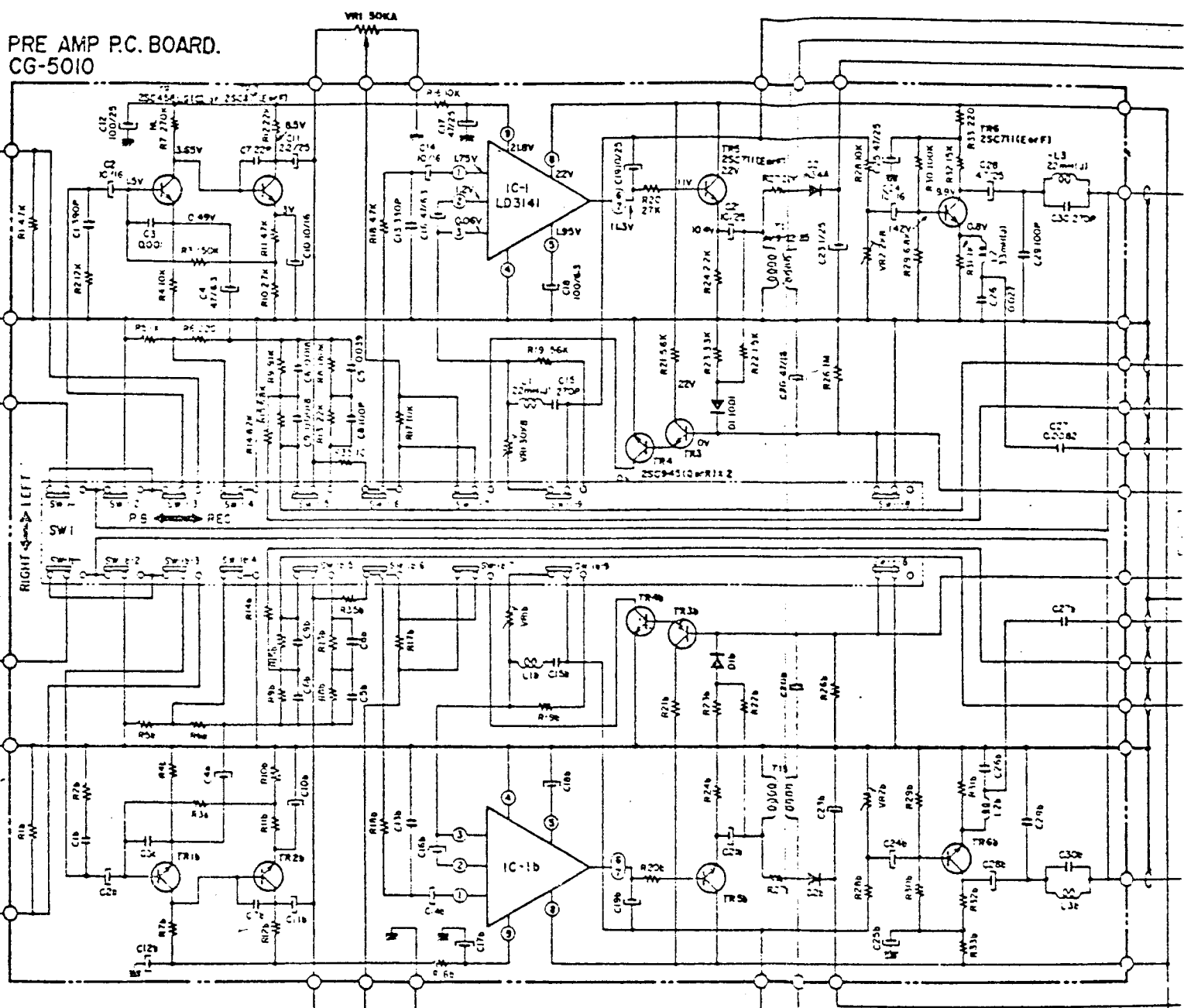

RESISTOR  
WATT  
LRHOR  
CONDENSER  
VOLTAGE  
ERROR  
MEANS

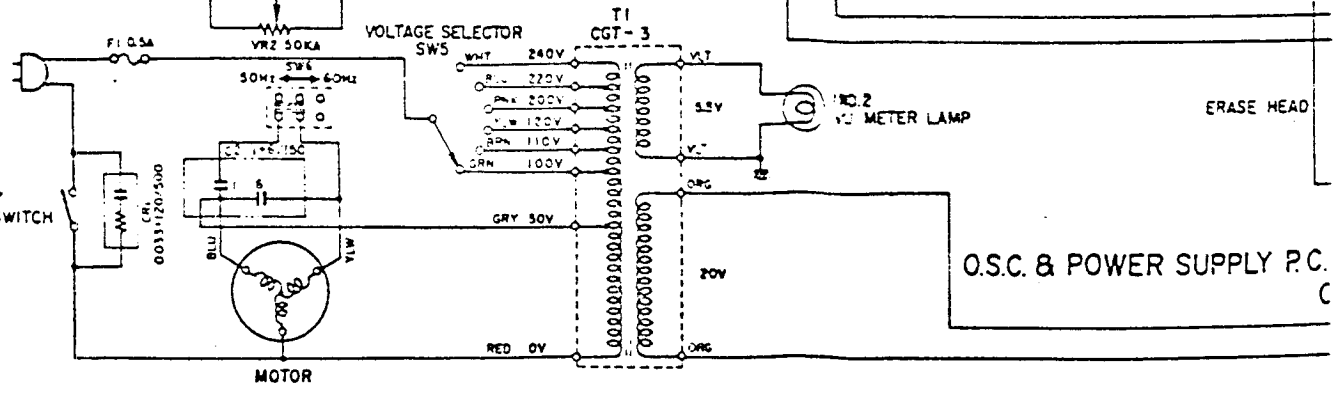

O.S.C. & POWER SUPPLY P.C.

ERASE HEAD

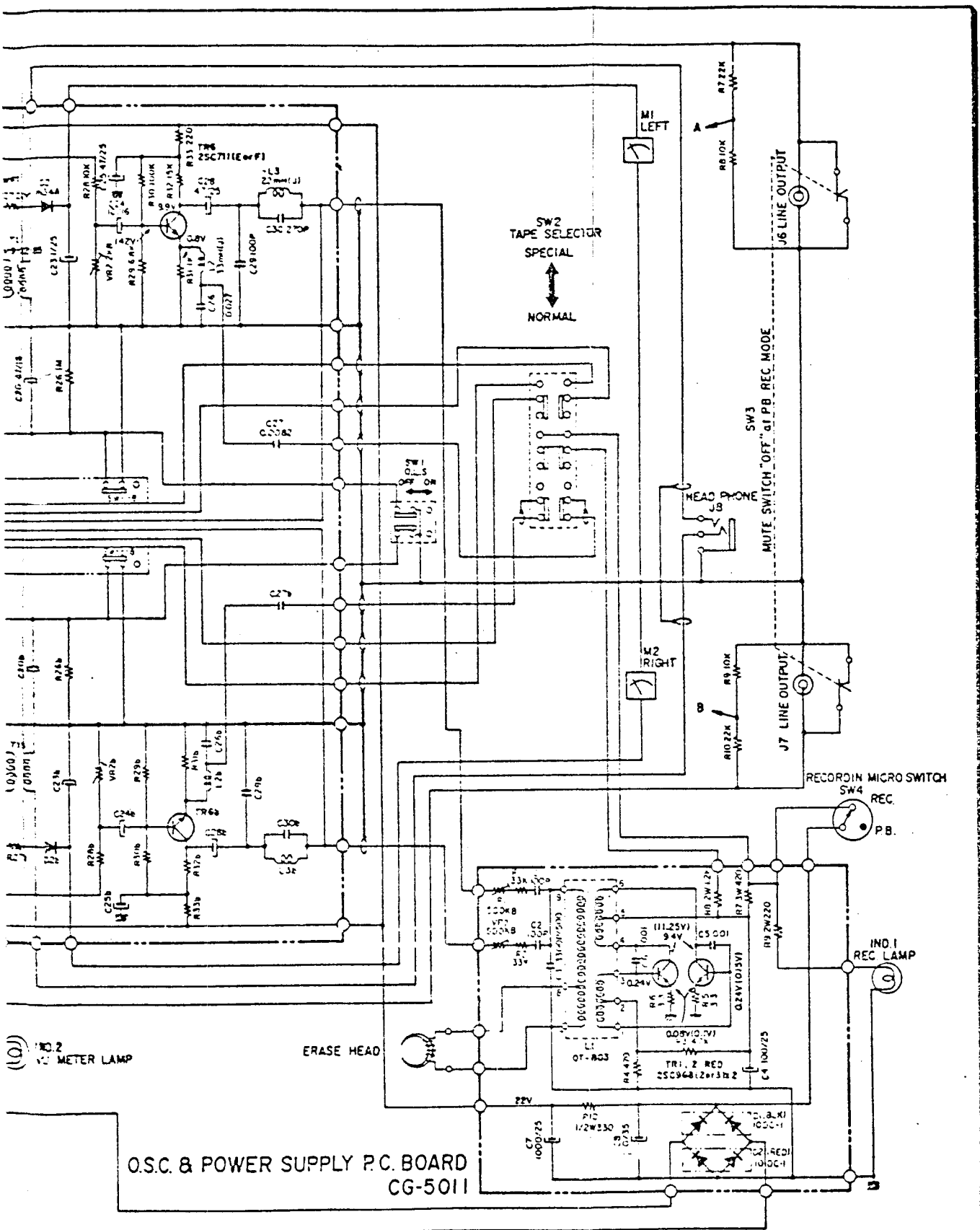

GXC-40D SCHEMATIC DIAGRAM  
1440213A