

SERVICE MANUAL

AKAI TAPE RECORDER

MODEL

M-9

TABLE OF CONTENTS

I	SPECIFICATIONS	1
II	MEASURING METHOD	2
III	LOCATION OF CONTROLS	4
IV	DISASSEMBLY OF TAPE TRANSPORT UNITS & AMPLIFIERS	5
V	TRANSPORT MECHANISM	7
VI	MECHANISM ADJUSTMENT	10
VII	AMPLIFIER ADJUSTMENT	12
VIII	MAINTENANCE PROCEDURES	15
IX	REPLACEMENT PARTS TABLE	16
X	EXPLODED VIEW OF COMPONENT PARTS	21
XI	TROUBLE SHOOTING CHART	
XII	SCHEMATIC DIAGRAM	

I. SPECIFICATIONS

STYLE : Portable
WEIGHT : 41.8 lbs (19 kg)
DIMENSIONS : 20" (H) x 13" (W) x 9-1/2" (D)
 (508 H x 340 W x 240 D mm)
POWER SUPPLY : AC 100 to 240 V, 50/60 Hz
RECORDING SYSTEM : In-line 4 track stereo, monaural recording by using Cross-field Bias Head.
TAPE SPEED : 3 speeds1-7/8", 3-3/4", and 7-1/2" (15" with 15 ips adaptor kit)
TAPE SPEED DEVIATION : Within $\pm 1\%$
WOW AND FLUTTER : Less than 0.15 % R.M.S. at 7-1/2" ips
 Less than 0.20 % R.M.S. at 3-3/4" ips
 Less than 0.30 % R.M.S. at 1-7/8" ips
FREQUENCY RESPONSE : 30 to 23,000 Hz ± 3 dB at 7-1/2" ips
 30 to 18,000 Hz ± 3 dB at 3-3/4" ips
 30 to 9,000 Hz ± 3 dB at 1-7/8" ips
SIGNAL TO NOISE RATIO: Better than 50 dB
DISTORTION (TOTAL HARMONICS) : Within 2 % at 1,000 Hz O VU (Line Out put)
 Within 5 % at 1,000 Hz 10 W (Main Out put)
CROSS-TALK : Less than -65 dB (Monaural)
 Less than -43 dB (Stereo)
ERASE RATIO : Less than -70 dB for all tracks
INSULATION RESISTANCE: More than 50M ohms.
INSULATION DURABILITY: 1,000 V. AC. for more than one minute duration.
POWER OUTPUT LINE OUTPUT : 1.228 V(0 VU) by using 250 Hz OVU Recorded Tape
 Impedance 1.5K ohms.
MAIN OUTPUT : 15 W maximum per each channel at undistorted power, total 30 W
 : 20 W maximum per each channel at music power total 40 W
 : Impedance 8 ohms.
INPUT LEVEL LINE INPUT : 50 mV ~ 2.5V
 Impedance 220K ohms
MIC. INPUT : 0.5 mV ~ 20 mV
 Impedance 4.7K ohms
DIN OUTPUT : 1.228 V (OVU) by using 250 Hz OVU recorded tape
 : Impedance 1.5K ohms

DIN INPUT : 20 mV
 : Impedance 100K ohms
FAST FORWARD AND REWIND TIME : 90 seconds for 1,200 ft.tape at 50 Hz
 75 seconds for 1,200 ft.tape at 60 Hz
MONITOR SYSTEM : Can be monitored the program being recorded by using
 Built-in speaker
 Stereo headphone
 External speakers
MOTOR : Hysteresis synchronous 2 speed motor
 Horse Power: 1/100 HP
 Power Ratio: 85 %
 Revolution : 3,000 to 1,500 R.P.M. at 50 Hz
 3,600 to 1,800 R.P.M. at 60 Hz
 Condenser capacity: 3 μ F at 50 Hz
 2 μ F at 60 Hz
HEADS REC/PLAY HEAD : Inline 4-track stereo/ monaural
 Gap 2/1000 mm
 Impedance 1,200 ohms at 1,000 Hz
BIAS HEAD : Inline 4-track stereo
 Gap 0.2 mm
 Impedance 500 ohms at 60K Hz
ERASE HEAD : Inline 4-track stereo
 Gap 0.2 mm
 Impedance 500 ohms at 60K Hz
RECORDING LEVEL INDICATOR : Vertical indication Model "A" VU meter x 2.
TRANSISTOR USED : 2SC458(B) x 2 2SC650(A) x 2.
 2SC649(B) x 2 2SC281(B) x 4
 2SC372 x 2 2SC367 x 2
 2SC490 x 4 2SC696(J),(I),(F)x2.
SELENIUM USED : SPN-01 x 1 Bridged selenium rectifier
SILICON DIODE USED : 5GB x 2
REELS USED : 7" , 5" , 3" reels

II. MEASURING METHOD

TAPE SPEED DEVIATION

1. Method involving use of pre-recorded tape

Playback on the tape recorder to be tested a tape pre-recorded at 1,000 cps \pm 0.1% for measuring tape speed deviation.

Connect the appropriate output to a frequency counter meter in order to measure the tape speed deviation from the resulting deviation of the measured frequency.

2. Method involving use of timing tape (designed for tape speed measurement)

This method utilizes a timing tape marked at intervals of 7-1/2". The running time of the tape over 60 marked sections is measured in order to calculate the deviation of the tape speed. In applying this method, however, it should be borne in mind that should the timing tape stretch or contract, measurement error is inevitable, so that it is necessary to measure the total length of the tape in advance.

WOW AND FLUTTER

Playback the 3,000 cps pre-recorded tape, whose wow and flutter level is guaranteed to be smaller than 0.07% for measurement by means of a wow meter. It is also possible for a 3,000 cps sine wave to be recorded and played for measurement by means of the wow meter. In this case, however, the wow meter indicates a value as much as twice the value given in the specification on the first page.

SIGNAL TO NOISE RATIO

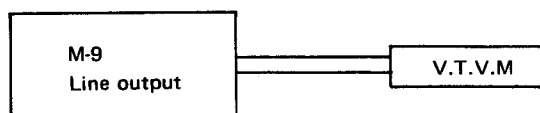

Set the Equalizer Switch on "7-1/2 ips" position and playback a tape containing a 1,000 cps sine wave recorded at "0" VU level on a standard recorder. Connect a V.T.V.M. to the line output jack of the recorder and measure its output. Then remove the tape and measure the noise level under the same condition. Convert each of the measured values into decibels.

TOTAL HARMONIC DISTORTION FACTOR

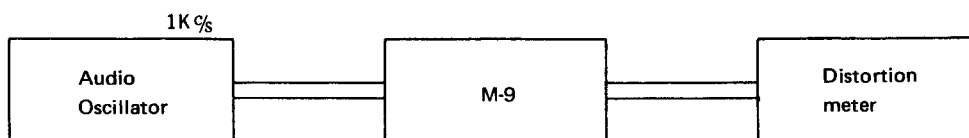

Connect the measuring instrument as shown above, and record the 1,000 cps sine wave at "0" VU. Playback the resultant signal and measure the overall distortion factor. Measure the noise level of the tape recorder with the tape removed; connect the audio oscillator directly to the distortion meter for measurement of the distortion factor of the oscillator.

The required distortion factor may be obtained from the results of the above measurement by the following formula.

$$d_0 = d - d_1 - d_2$$

where,

- d_0 = Required
- d = Overall distortion factor
- d_1 = Noise level
- d_2 = Distortion factor of the oscillator

(Note: New tape of particularly good quality should be used for measurement of the distortion factor).

POWER OUTPUT

Playback a tape containing a sine wave of 1,000 cps recorded at 0 VU on a standard recorder.

Connect a V.T.V.M. to the line output jack of the recorder and measure the voltage at the output of the recorder to be tested.

CROSS TALK (Cross talk between the tracks)

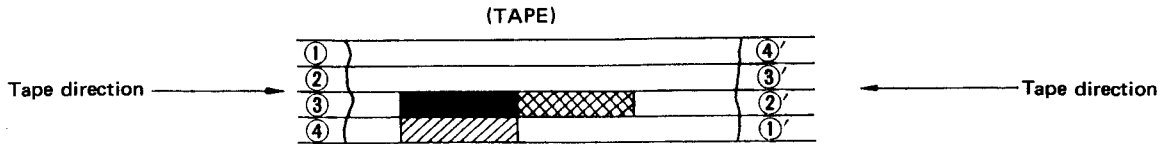

As shown in the figure, first record a 1,000 cps sine wave on track No. 3 at +3 VU level. Next, remove the 1,000 cps input signal and record under a non-input condition.

Then, playback the tape on track No. 3 and No. 1 (reversed condition of tape) through the 1,000 cps B.P.F. (Band Pass Filter, Sensitivity 1 : 1) and obtain a ratio between the two from the following formula.

$$C = 20 \log \frac{E_0}{E_2 - E_1} \text{ (db)}$$

C = Desired cross talk ratio (db)

E_0 = 1,000 cps signal output level

E_2 = 1,000 cps cross talk output level

E_1 = No-input signal record level



FREQUENCY RESPONSE

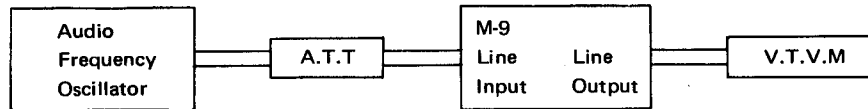

Connect the measuring instrument as in the above diagram, and measure the frequency response in the following sequence:

RECORD:

- 1) Give a sine wave of 1,000 cps to the Line Input of the recorder to be tested through an attenuator from an audio frequency generator.
- 2) Set the Record/Playback Knob in "Rec" position and adjust the line input volume so that the VU meter needle indicates "0" VU.
- 3) Under the condition described in (2), lower the input level 10 db by means of the attenuator.
- 4) Record the spot frequency in the range of 30 cps to 25,000 cps from the audio frequency generator.

PLAYBACK:

- 5) Set the Record/Playback Knob in "Play" position.
- 6) Set the Equalizer Switch on 7-1/2" or 3-3/4" position.
- 7) Connect a V.T.V.M. to the Line output.
- 8) Playback the tape previously recorded.
- 9) Adjust the output level to "0" dbm at 1,000 cps as indicated on the V.T.V.M. by the range selector of a V.T.V.M.
- 10) Playback the recorded spot frequencies with the conditions in (9); make a memo of output level and plot the value on a graph.

III. LOCATION OF CONTROLS

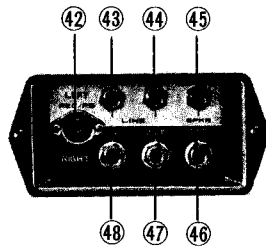
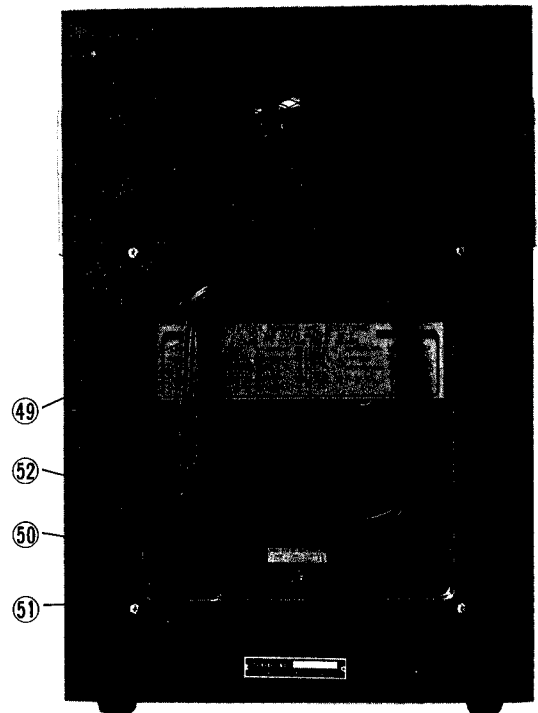
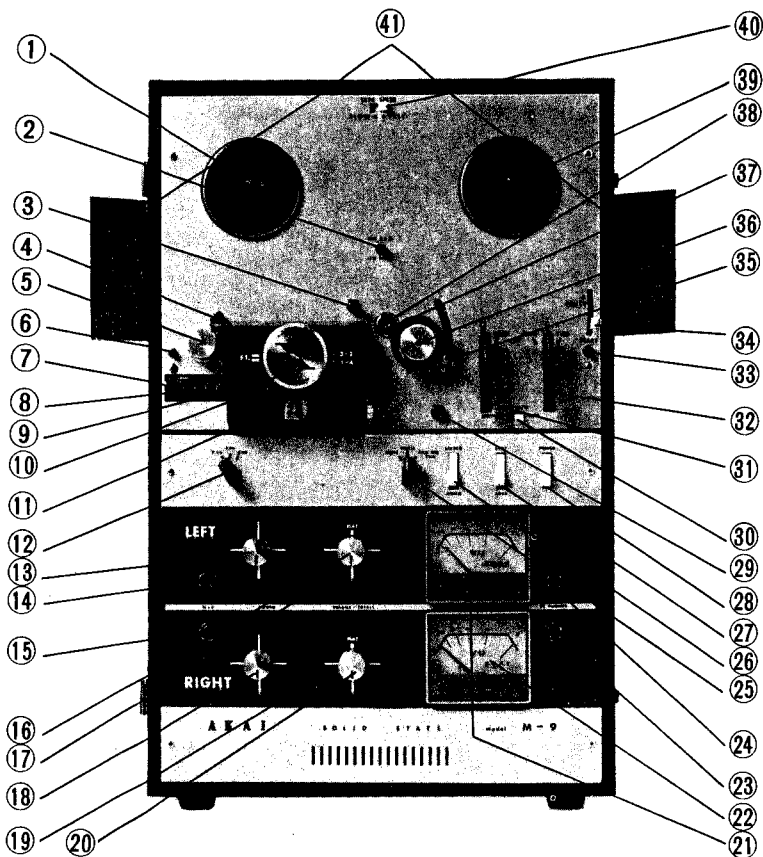

- | | | |
|--|---|------------------------------------|
| (1) Supply Reel Shaft | (18) Recording Level Control Knob (Right) | (35) Automatic Shut-Off Lever |
| (2) Cycle Conversion Switch (A) | (19) Treble Control Knob (Right) | (36) Pinch Wheel |
| (3) Capstan Storage Post | (20) Volume Control Knob (Right) | (37) Capstan |
| (4) Tape Cleaner | (21) VU Meter (Left) | (38) Capstan Shaft |
| (5) Tape Guide | (22) VU Meter (Right) | (39) Take-up Reel Shaft |
| (6) Cleaner Button | (23) Stereo Headphone Jack (A) | (40) Speed Change Switch |
| (7) Reset Button | (24) Stereo Headphone Jack (B) | (41) Speaker Reflectors |
| (8) Index Counter | (25) Recording Mode Switch | (42) DIN Jack |
| (9) Track Selector Knob | (26) Function Switch | (43) Line Input Jack (Left) |
| (10) Head Cover (A) | (27) Bass Switch | (44) Line Output Jack (Left) |
| (11) Head Cover (B) | (28) Power Switch | (45) External Speaker Jack (Left) |
| (12) Equalizer Knob | (29) Record Safety Button | (46) External Speaker Jack (Right) |
| (13) Recording Level Control Knob (Left) | (30) Automatic Stop/Shut-Off Switch | (47) Line Output Jack (Right) |
| (14) Microphone Jack (Left) | (31) Record/Playback Knob | (48) Line Input Jack (Right) |
| (15) Microphone Jack (Right) | (32) Fast Forward/Rewind Knob | (49) AC Cord |
| (16) Volume Control Knob (Left) | (33) Start Button | (50) Fuse Post |
| (17) Treble Control Knob (Left) | (34) Instant Stop Lever | (51) Cycle Conversion Switch (B) |
| | | (52) Voltage Conversion Switch |

IV. DISMANTLING OF TAPE TRANSPORT UNIT & AMPLIFIERS

DISASSEMBLY OF TAPE TRANSPORT

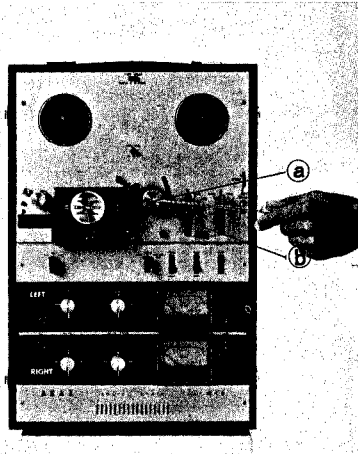

(1) Loosen the RETAINING SCREW (a) of PINCH WHEEL (b) using a phillips-headed screw driver and remove the PINCH WHEEL by hand.

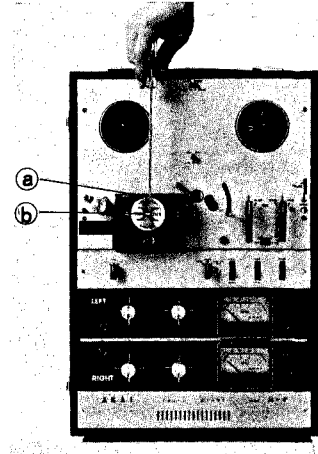

(2) Loosen the RETAINING SCREW (a) of the TRACK SELECTOR KNOB (b) using a phillips-headed screw driver and remove the TRACK SELECTOR KNOB by hand.

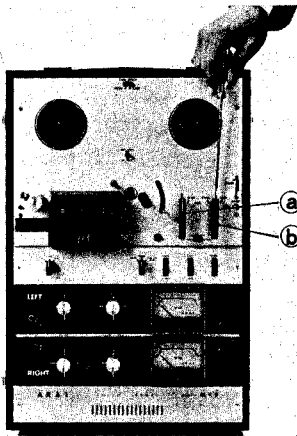

(3) Loosen the RETAINING SCREWS of the DECK CONTROL KNOBS ((a) and (b)) by using a phillips-headed screw driver and remove the KNOBS by hand.

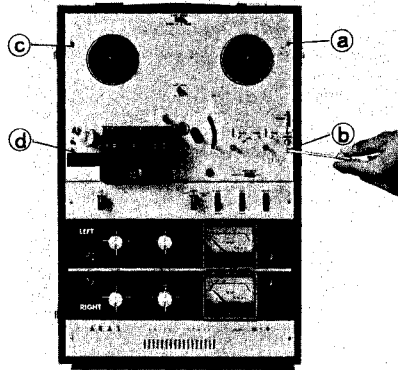

(4) Loosen the SCREWS (marked from (a) to (d)) by using a phillips-headed screw driver and remove the DECK PANEL by hand.

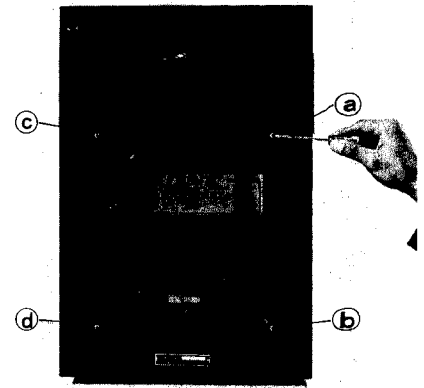

(5) Loosen the SCREWS (marked from (a) to (d)) by using a phillips-headed screw driver.

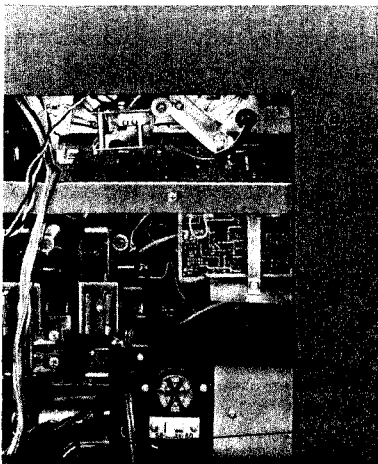

(6) Disconnect the PLUGS ((a) and (b)) carefully by hand.

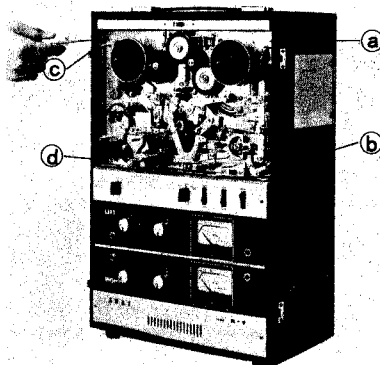

(7) Loosen the SCREWS (marked from (a) to (d)) of the DECK FRAME by using a phillips-headed screw driver.

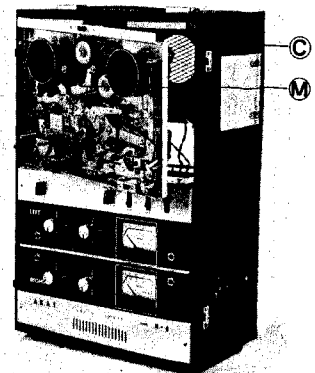

(8) Remove the TAPE TRANSPORT MECHANISM ASSEMBLY (M) by slowly lifting it from the CASE (C) as shown in picture.

DISASSEMBLY OF AMPLIFIER

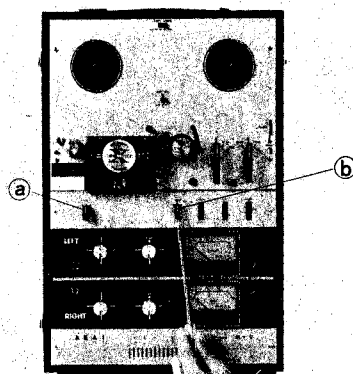

- (1) Loosen the RETAINING SCREWS of the RECORDING MODE SWITCH and EQUALIZER SWITCH (a) and (b) by using a philipsheaded screw driver and remove the KNOBS by hand.

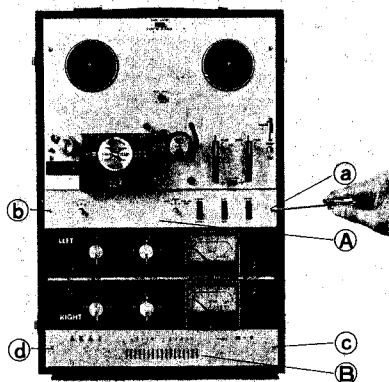

- (2) Loosen the SCREWS (marked from (a) to (d)) by using a philipsheaded screw driver and remove the AMPLIFIER PANELS (A) and (B) by hand.

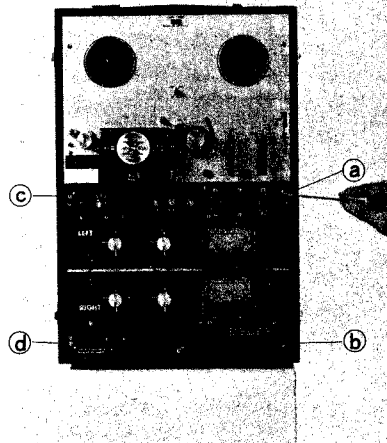

- (3) Loosen the SCREWS (marked from (a) to (d)) by using a philipsheaded screw driver.

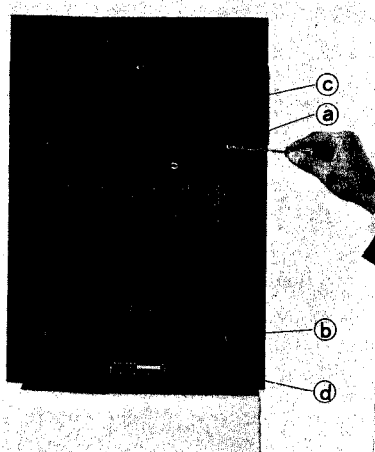

- (4) Loosen the SCREWS (marked from (a) to (d)) by using a philipsheaded screw driver.

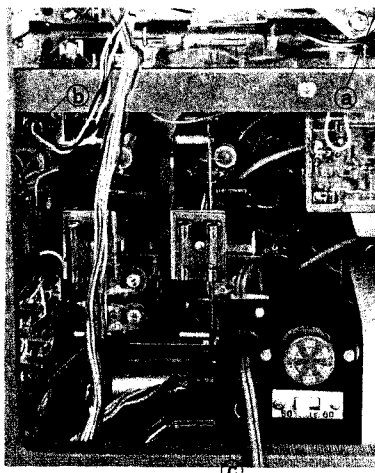

- (5) Disconnect the PLUGS (marked (a) to (c)) carefully by hand.

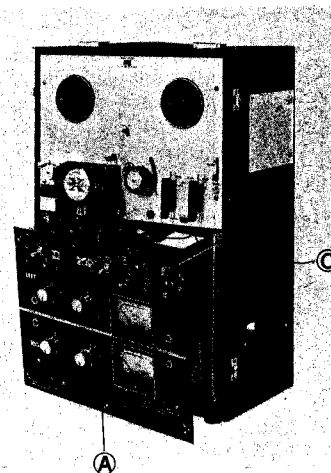

- (6) Remove the AMPLIFIER ASSEMBLY (A) by slowly lifting it from the CASE (C) as shown in picture.

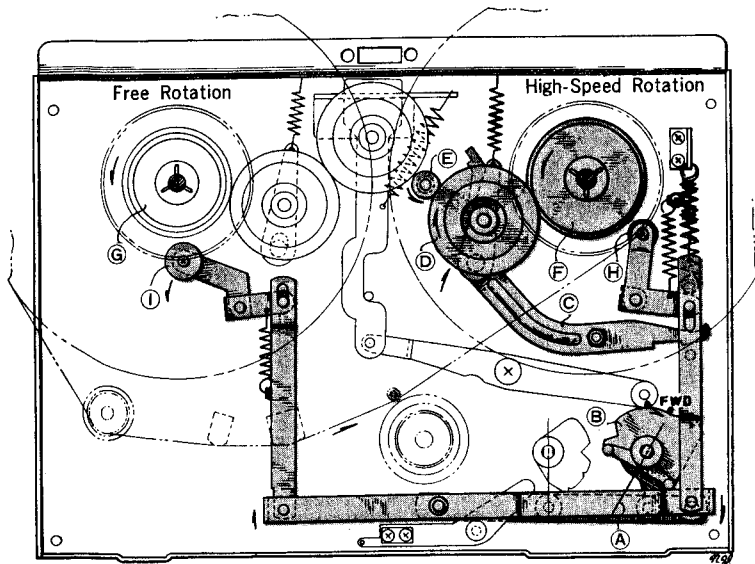

Fig. 3

FAST-FORWARD MECHANISM

Turn the *FAST FWD-REWIND knob (A)* in "FAST FWD" position, and the *cam (B)* under the knob pushes up the *Lever (C)*. The *Idler (D)* moves into the space between the *Plastic Roller (F)* above the *Take-Up Reel Spindle* and the upper part of the rotating motor drive bushing to transmit the motor rotation to the take-up reel spindle. At the same time, *Brake Rollers (H)* and *(I)* come off the reel spindle to free the *Supply Reel Spindle (G)*, thereby allowing fast winding of the tape onto the take-up reel. (See figure 3)

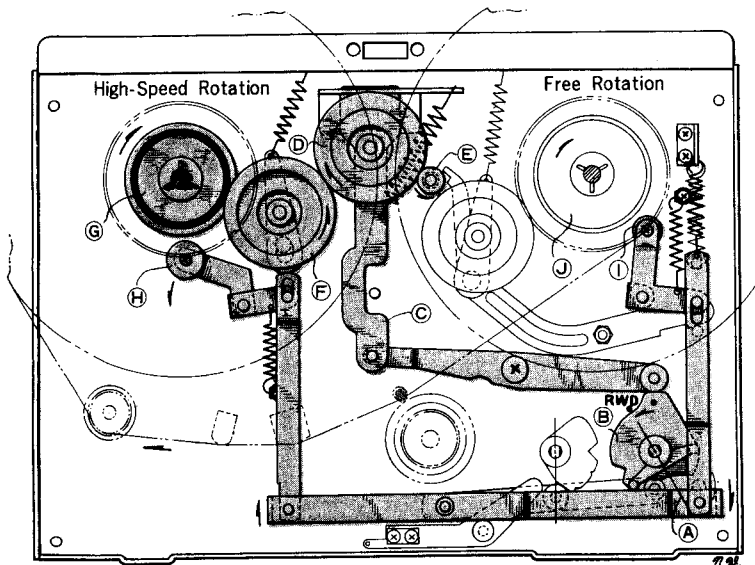

Fig. 4

REWIND MECHANISM

Turn the *FAST FWD-REWIND knob (A)* in "REWIND" position, and the *cam (B)* under the knob pushes the *Lever (C)* up. The *Idler (D)* moves into the space between the upper part of the rotating *Motor drive bushing (E)* and the *Intermediate Pulley (F)* to transmit the high-speed rotation of the motor through the intermediate pulley to the *Supply Reel Spindle (G)*. At the same time, *Brake Rollers (H)* and *(I)* come off the reel spindle to free the *take-up reel spindle (J)*, thereby rewinding the tape into the supply reel at a fast speed. (See figure 4)

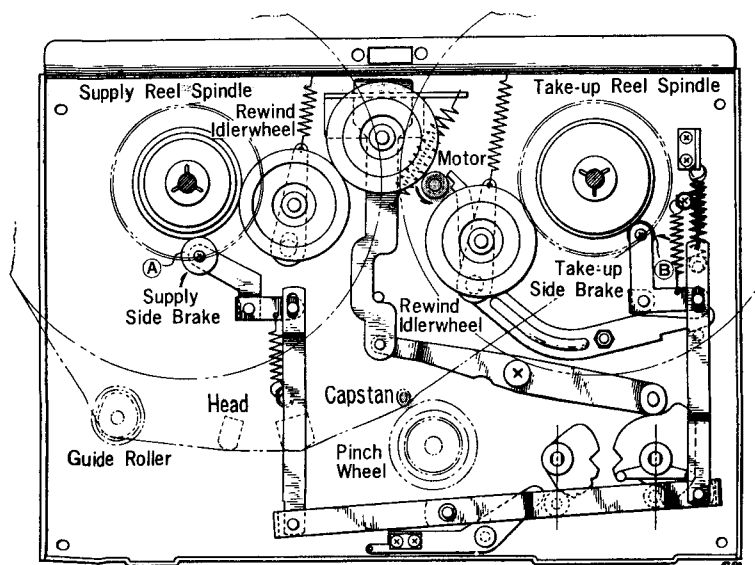

Fig. 5

STOP CONTROL

Turn the stop lever in "STOP" position, *Brake Rollers (A)* and *(B)* depress reel spindles to stop rotation of the reel spindles. As the brake rubber depresses the plastic rollers under the reel spindles, no friction is brought to bear on the tape itself.

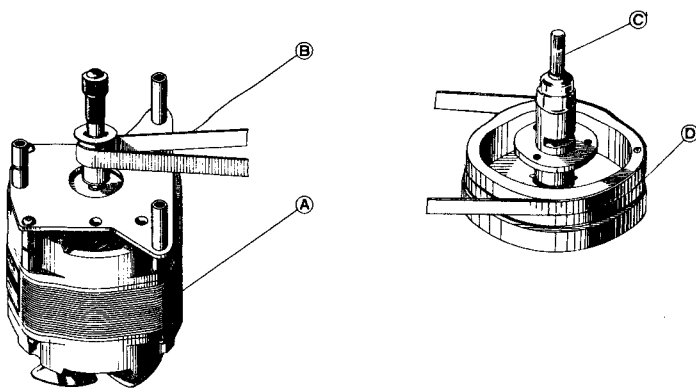

Fig. 1

DRIVING OF CAPSTAN

Figure 1.

- (A) Motor
- (B) Driving Belt (flat belt)
- (C) Capstan
- (D) Flywheel

High-speed rotation of *Motor* (A) is reduced by *Driving Belt* (B) and transmitted to *Capstan* (C), which is connected with flywheel with ample inertia. This enables the rated rotation to be attained by absorbing minor rotation distortion of motor itself.

Capstan Rotation:

606 R.P.M. at 7-1/2" (19 cm) per sec.

303 R.P.M. at 3-3/4" (9.5 cm) per sec.

151.5 R.P.M. at 1-7/8" (4.75 cm) per sec.

Motor Rotation:

3,000 to 1,500 R.P.M. at 50 cps.

3,600 to 1,800 R.P.M. at 60 cps.

DRIVING OF PINCH WHEEL

Put tape between rotating capstan and pinch wheel, and push the pinch wheel against the capstan. This will transport the tape at rated speed. The appropriate pressure of pinch wheel is between 1,000 and 1,150 grams at the tape speed of 7-1/2" (19 cm) per second.

RECORDING AND PLAYBACK

Turn the RECORD/PLAYBACK KNOB (A) to "PLAY" position, and pinch wheel presses against capstan to move tape at the rated speed. At the same time, *Idler* (b) moves between *Motor Bushing* (C) and the *Take-Up Reel Spindle* (D) to transmit the motor rotation to (D) so that the tape is moved and wound on the take-up reel.

The Take-up Reel Spindle Base is made up of two plastic rollers (1 and 2) with a clutch felt in between. The *Idler* is rotating the plastic roller (2) underneath. Therefore, the tape-winding friction is adjusted by the slipping of the felt to maintain the rated winding of the tape. On the other hand, the *Supply Reel Spindle* (H) has a *Brake Roller* (E) hung on the Plastic Roller (4) underneath, which provides appropriate back tension by the clutch felt slipping to the rotation of the Pulley (3) above.

To prevent accidental erasure, the *Record Interlock Button* (F) must be depressed before the RECORD/PLAYBACK KNOB can be moved to the "REC" position. The *Safety device* (G) is depressed to operate the recording mechanism.

(See Figure 2)

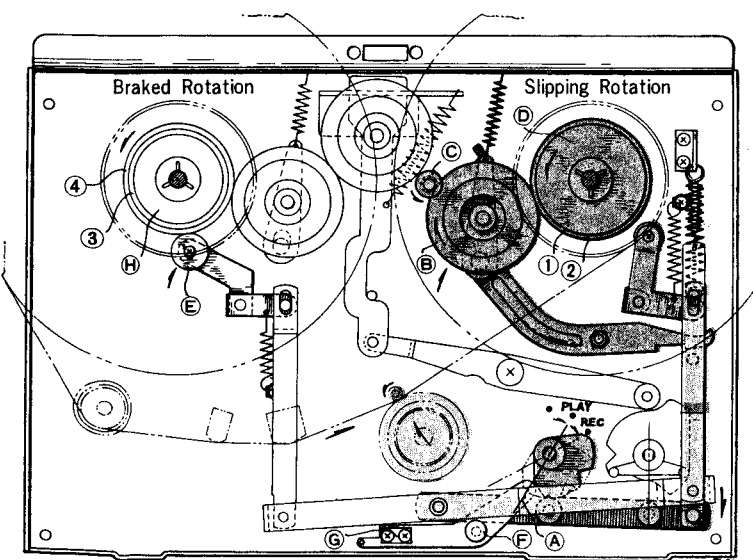

Fig. 2

Modes of Operation	Pinch Wheel	Take-up Idler Wheel	Rewind Idler Wheel	Take-up side Brake	Supply side Brake
(a) STOP	X	X	X	○	○
(b) FAST-FORWARD	X	○	X	X	X
(c) REWIND	X	X	○	X	○
(d) RECORDING PLAYBACK	○	○	X	X	X

NOTES: X- marks indicates "open" and
○- marks "engaged"

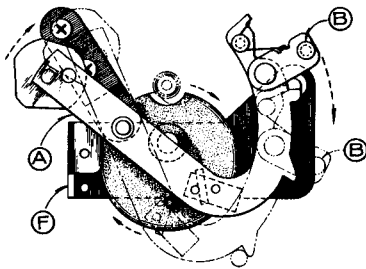

Fig. 6

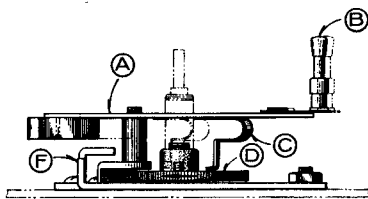

Fig. 7

AUTOMATIC STOP MECHANISM

When the tape is threaded on the pin (B) at the top of the Automatic Stop Lever (A) comes off the pin, the Automatic Stop lever returns to the original position by the action of springs. At this time, the panel spring (C) below the Automatic Stop lever slightly pushes down the projected part of the eccentric gear (D), which gears into the Flywheel Gear (E) to start rotating and pushing up the Instant Stop Lever (G) that is connected with the eccentric gear base (F).

Thus, the eccentric gear maintains the mechanism in the state of tentative stop for "Playback" or "Recording".

For "Fast-forward", or "Rewind", the Corkscrew lever (H) works to push back the "FAST FWD, REWIND" knob to the "Stop" position before stopping itself.

When the Automatic Shut-OFF Switch is moved to "SHUT OFF" position, the Shut-Off Lever (J) moves to the arrow-mark direction to cut the power circuit, thereby depressing the attached Micro Switch (K) to shut off the current.

(See a, b, c and d in Fig. 9)

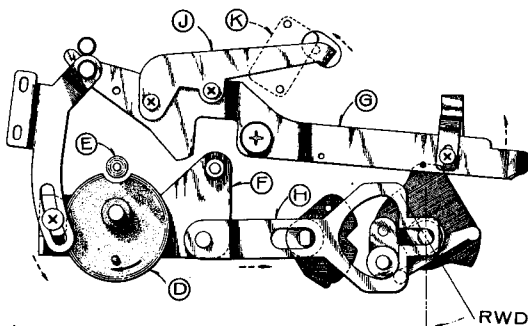

Fig. 8

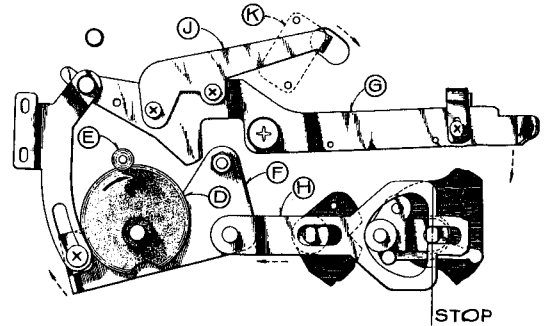
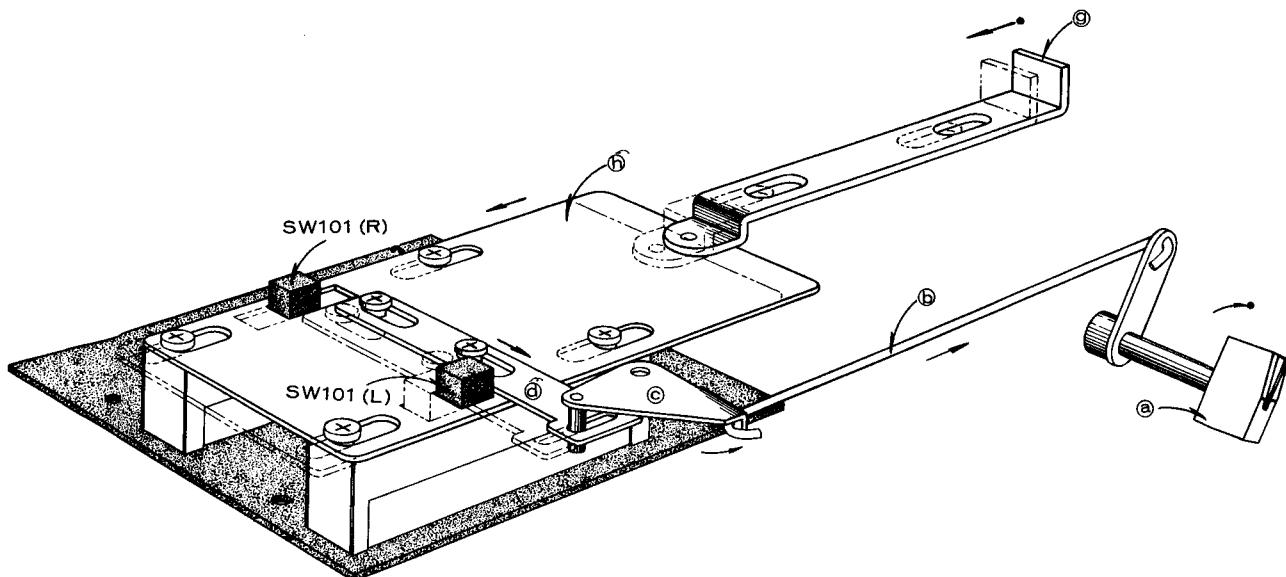
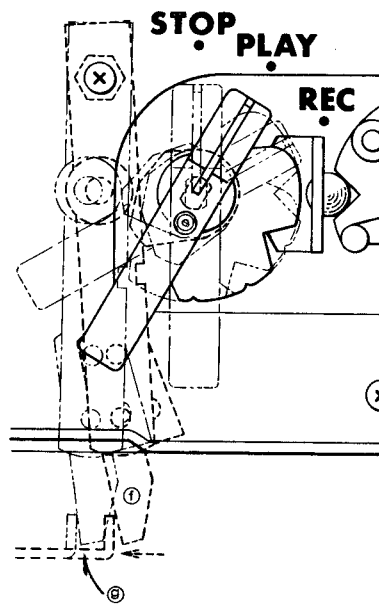

Fig. 9

SOUND ON SOUND MECHANISM OPERATES

- (A) By turning the Recording Mode Switch Knob (a) to the "Sound on Sound" position, the lever (b) pulls the lever (c). This in turn pulls the lever (d) which slides out from the Right Channel Recording Switch (SW-101 R).
- (B) At this position, turn the Record/Playback Knob (e) to the "REC" position. The lever (f) pushes the recording lever (g) and lever (g) in turn pushes the lever (h).
- (C) This sets the Left Recording Switch (SW-101 L) at the recording position. The left channel of the amplifier is then used for recording.
- (D) But the Right Recording Switch (SW-101 R) will not be set at the recording position. The right channel of the amplifier is used for play back.

This is how the Sound on Sound Mechanism Operates.



VI. MECHANISM ADJUSTMENT

1. ADJUSTMENT OF PINCH WHEEL

It is important that the pinch wheel shaft is kept in complete alignment with the capstan shaft. A proper pinch wheel pressure is between 1,000 and 1,150 grams when the unit is operated at the tape speed of 7-1/2 ips. Any deviation from this specification will result in wow and flutter. Check pinch wheel pressure by a spring scale, and if necessary, adjust the pinch wheel load spring.

2. ADJUSTMENT OF TAKE-UP IDLER WHEEL

The take-up idler wheel must be kept in complete alignment with the take-up reel shaft. When the unit is set in fast forward condition, the idler wheel will contact with the upper knurled wheel of the take-up reel shaft assembly, and it will contact with the lower knurled wheel during record or play operation. Adjust idler wheel load spring so that the idler wheel pressure is kept between 50 and 80 grams. The idler wheel rapidly wears if the pressure is excessive. Slippage occurs if the pressure is smaller than the specification.

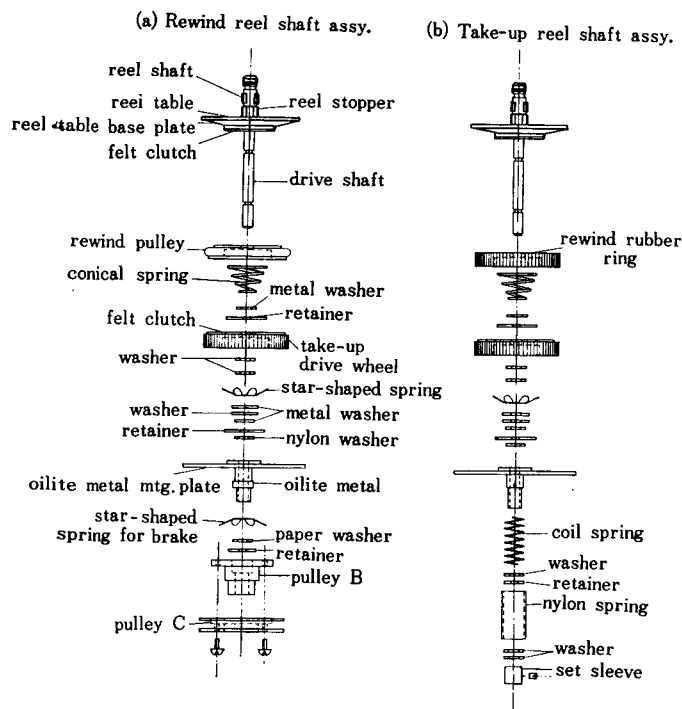

Fig. 1

3. ADJUSTMENT OF REWIND IDLER WHEEL

The rewind idler wheel must be kept in complete alignment with the rewind reel shaft. The amount of pressure on the knurled motor bushing should be maintained at about 50 grams during rewind operation. Adjust both the idler load spring and rewind roller.

4. ADJUSTMENT OF INTERMEDIATE WHEEL

The intermediate wheel is located between the rewind idler wheel and the rubber ring which is used on the upper part of the supply reel shaft assembly. When the unit is set in rewind condition it will contact with these parts simultaneously transmitting torque of motor. An adequate pressure is 50 grams. Adjust the load spring of the intermediate wheel if the pressure is not sufficient.

5. ADJUSTMENT OF TAKE-UP REEL SHAFT ASSEMBLY

Felt clutch material is attached to the bottom side of the reel table base plate so that recording tape will not be stretched during fast forward operation because of excessive tension. To check the amount of friction of this part, place a 5-inch reel with a tape 60 m/m in diameter, and gently pull the end of tape upward using a spring scale. Adjust the conical spring so that the amount of tension at this part will be kept between 400 and 500 grams. Other felt clutch material is attached to the take-up drive wheel. It is to provide proper slipping operation during record or play operation. The procedure for checking friction of this part is the same as the foregoing, and between 150 and 200 grams of friction will provide the best result. Adjust the star-shaped spring just under the take-up drive wheel. When the unit is set to rewind operation, the amount of friction of this part will be greatly reduced and will become 15 to 20 grams. Check to see whether this is satisfactory, if not, readjust the star-shaped spring for Brake, and the pressure of the spring retainer will be accordingly. (See figure 1 (b) at left)

6. ADJUSTMENT OF SUPPLY REEL SHAFT ASSEMBLY

Felt clutch material is used between the lower side of the reel table base plate and the rewind rubber ring to protect recording tape from excessive tension during the rewinding operation. To check the amount of friction of this part, place onto the supply reel table a 5-inch reel with a tape 60 m/m in diameter, and gently pull the end of tape upward by a spring scale. Adjust the conical spring so that the amount of tension is kept between 400 and 500 grams. Other felt clutch material is attached to the rewind drive wheel to provide proper slipping operation during record or play operation. The procedure for checking friction of this part is the same as the foregoing, and between 80 and 120 grams of friction will give the best result. When the unit is set to fast forward operation, the amount of friction will be greatly reduced and will become 15 ~ 20 grams.

Check to see whether this is correct. If not, readjust coil spring and spring retainer washer. (See figure 1 (a) at left)

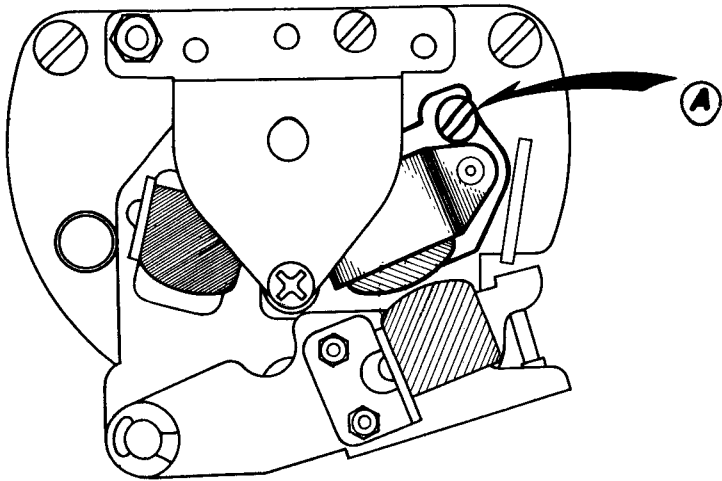

Fig. 2

7. ADJUSTMENT OF HEADS

- a. Azimuth alignment of the Recording/Playback Head (See Fig. 2)

Playback an Ampex Alignment Tape 8,000 Hz at 7-1/2" tape speed and turn the screw (A) until the Line Output Level reaches the Maximum.

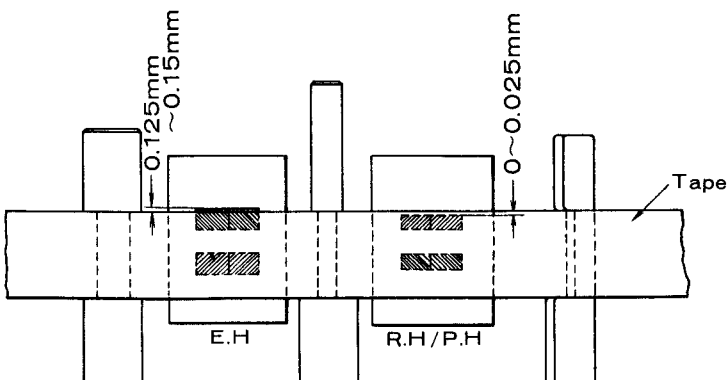

Fig. 3

- b. Angle of the Bias Head (See Fig. 2 and Fig. 4)
Unfasten two screws (B), (C), and move the Bias Head by hand until the center line (d) of the Bias Head makes an angle of 90° with the direction of the tape. Then fasten screws (B) and (C).

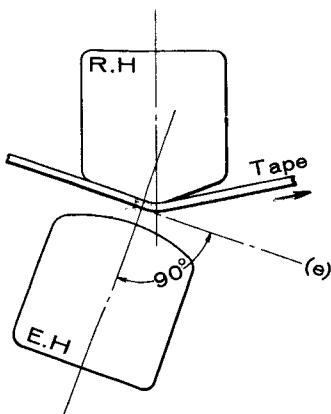

Fig. 4

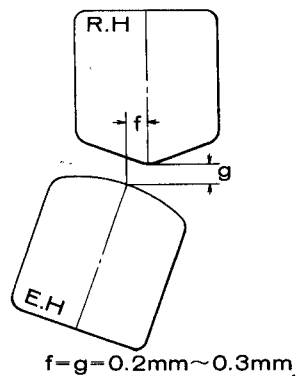

Fig. 5

- c. Clearance of the Bias Head (See Fig. 5)
Unfasten two screws (B), (C) and move the Bias Head by hand until the clearance (f) and (g) reaches 0.2 - 0.3 mm. Then fasten screws (B) and (C).

Note: If the clearance (f) and (g) becomes less than 0.2 - 0.3 mm, the Frequency Characteristic will be too low, but Distortion will decrease. If the clearance (f) and (g) becomes more than 0.2 - 0.3 mm, the Frequency Characteristic will be too high, but Distortion will increase.

VII AMPLIFIER ADJUSTMENT

1. ADJUSTMENT OF RECORDING BIAS FREQUENCY

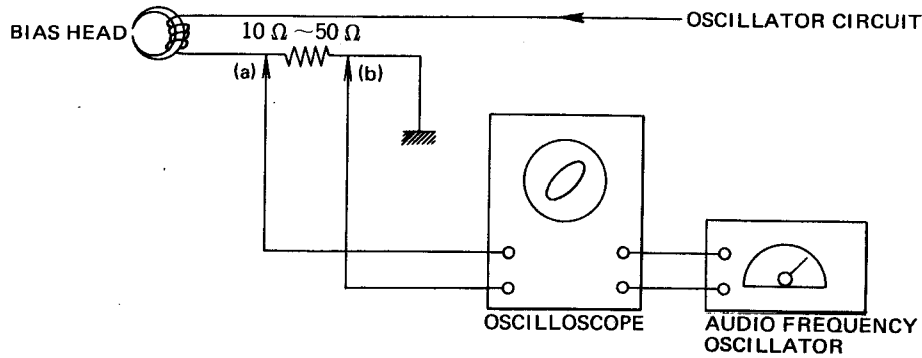

Fig. 1

- Put on the resistor 10 or 50 ohms in series with the Bias Head and connect the Vertical Input Terminal of the Oscilloscope to points (a) and (b).
- Feed in the sine wave signal from an Audio Frequency Oscillator to the Horizontal Input of the Oscilloscope and tune the Dial of the Audio Frequency Oscillator until the Oscilloscope displays a circular or linear pattern. Then read the figure on the Dial of the Audio Frequency Oscillator.
- If it reads 60K Hz \pm 5K Hz, the Recording Bias Frequency is correct.
- If it is not correct, it may be adjusted by inserting another condenser (C-405) value 9,000 PF.

2. ADJUSTMENT OF RECORDING BIAS VOLTAGE

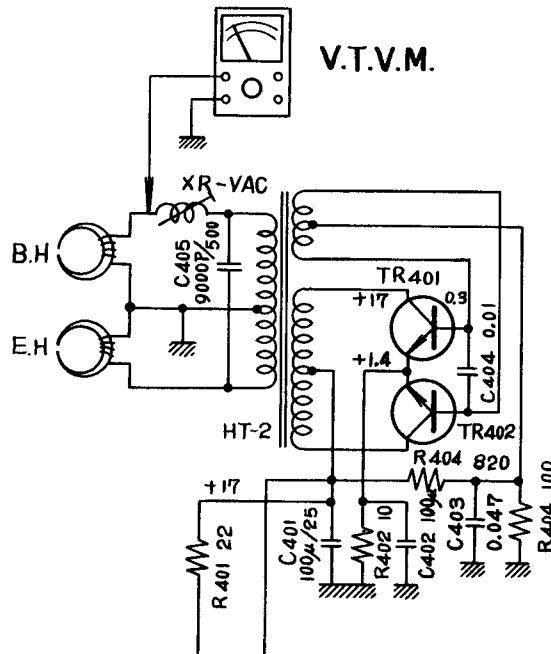

Fig. 2

Connect the V.T.V.M. to the point (A) and adjust the recording bias voltage by turning the V.A.C. in the bias oscillator circuit until it reads the voltage stamped backside the head assembly.

Note:

There is no way of adjusting the erasing bias voltage, but the correct bias voltage is between AC 60 V and 80 V.

3. ADJUSTMENT OF LINE OUTPUT LEVEL

(A) Playback (See Fig. 3)

- Set the Record/Playback Knob to "Play" position and the Equalizer Switch to 7-1/2".
- Connect the V.T.V.M. (use one with Milli-Volt scale) to the Line Output Jack.
- Playback the test tape (250 Hz "0" VU recorded) at 7-1/2" tape speed and turn the volume VR-201 (20KB) until the Line Output level reaches "0" VU 1.228 V (+4dB).

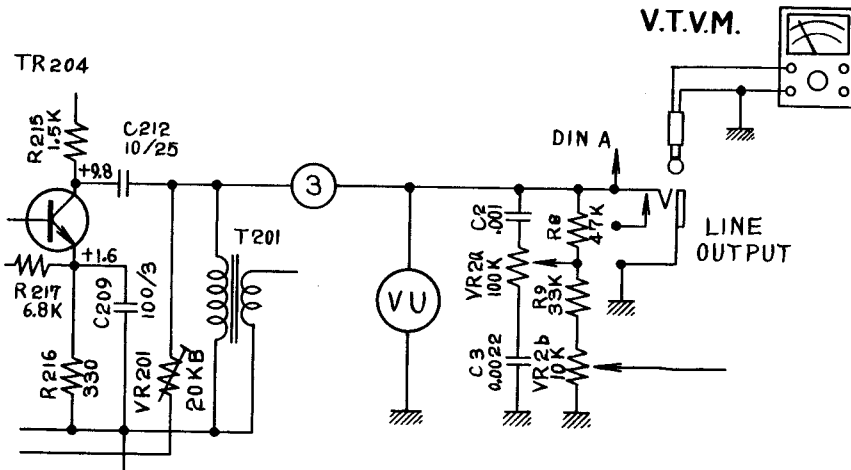

Fig. 3

(B) Recording and Playback (See Fig. 4)

- Connect V.T.V.M. to the Line Output Jack and put on a Scotch-111 blank tape.
- Set the Record/Playback Knob to "REC" position and the Equalizer Switch to 7-1/2".
- Feed in a 1,000 Hz sine wave signal from an Audio Frequency Oscillator to the Line Input of the M-9 and turn the Recording Level Volume Control VR-1 (50K-A) until the Line Output Level reaches "0" VU 1.228 V (+4dB).
- After a few seconds of recording, rewind the tape back to the starting position. Then playback the tape.
- If the Line Output Level does not reach "0" VU, turn the Volume VR-3 (2KB) until the Line Output Level reaches "0" VU.

Repeat this process 2 or 3 times as indicated in c. and d. above.

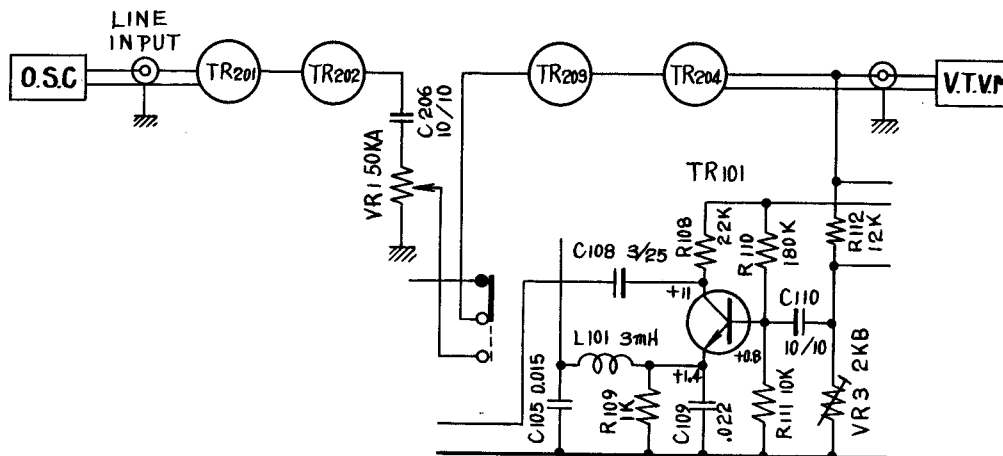

Fig. 4

4. ADJUSTMENT OF D.C. COLLECTOR CURRENT FOR POWER TRANSISTORS 2SC-490 WITH NO INPUT SIGNAL (SEE FIG.5)

- Disconnect the wire between points (a) and (b), (c) and (d).
- Connect the Ampere Meter (use one with Milli-Ampere Scale) to the points (a) and (b), (c) and (d).
- Connect the point (e) to the Earth position.
- Turn the Volume Control back to the minimum position.
- Turn the Volume VR-301 (100-B) until the D.C. Collector Current reaches 28 mA.

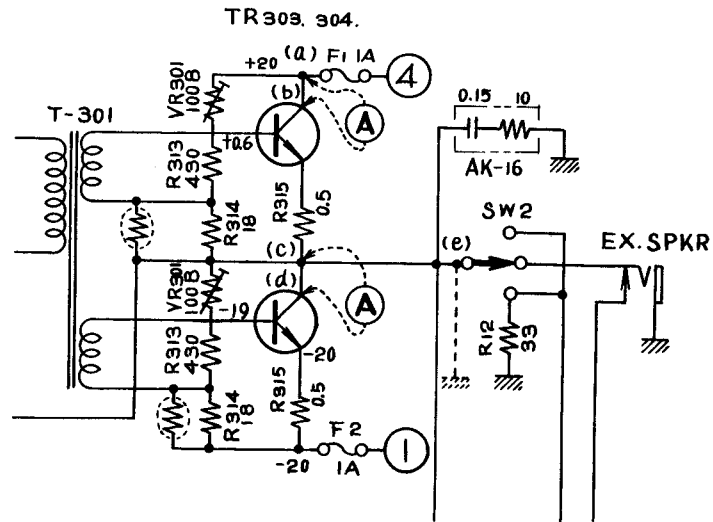

Fig. 5

VIII. MAINTENANCE PROCEDURES

1. LUBRICATION INSTRUCTION

For maximum service life and optimum performance, lubricate the parts identified below after each 500 hours of operation. Use only light machine oil of good quality.

Motor	
Flywheel Assembly	
Rewind Idler Wheel and Wind Take-Up Idler	1 drop
Intermediate Idler	1 drop
Pinch Wheel	1 drop

Also apply a liberal film of light machine grease to each roller surface of all levers and cams.

CAUTION: DO NOT OVER-LUBRICATE, AND WIPE OFF EXCESS OIL BY A COTTON SWAB SOAKED IN ALCOHOL. OTHERWISE, THE EXCESS LUBRICANT MAY BE SCATTERED DURING OPERATION, AND THE RUBBER COMPONENT PARTS WILL DETERIORATE.

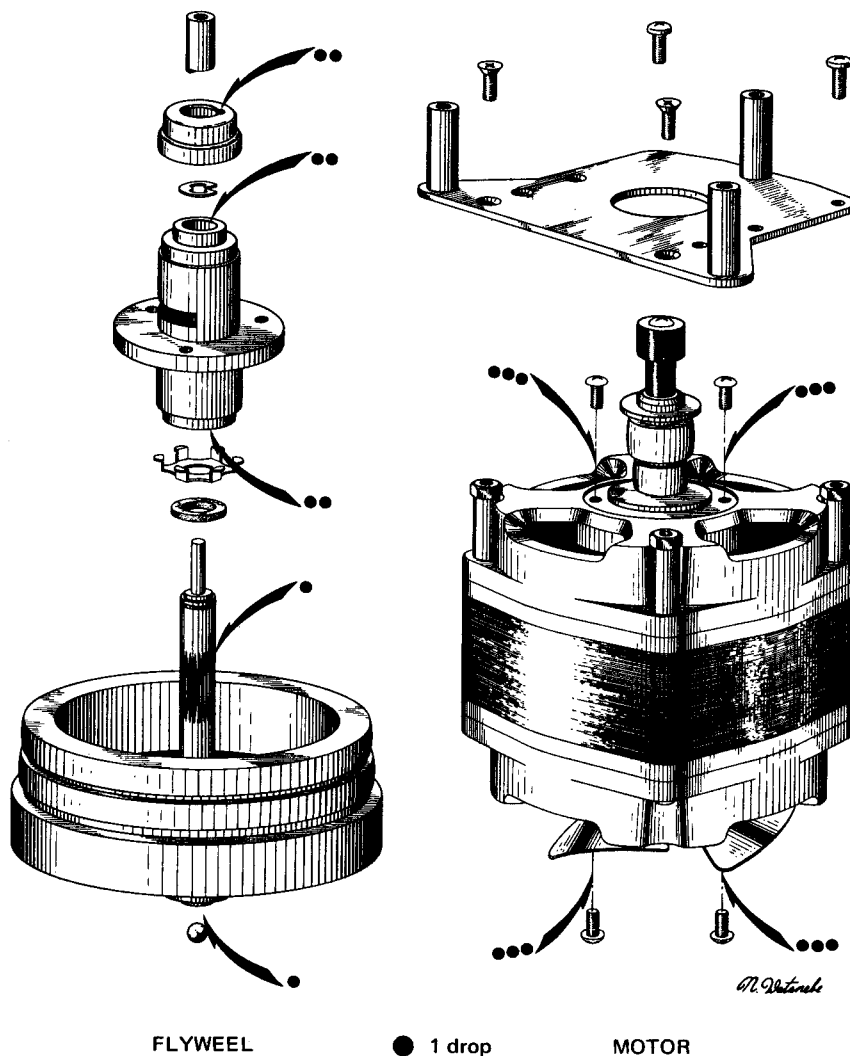

Fig. 1

2. CLEANING TAPE HEADS AND OTHER PARTS

Wipe surface of tape heads, guide roller bearing, capstan bushing and pinch wheel periodically with a soft cloth soaked in alcohol or carbon-tet.

IX. REPLACEMENT PARTS TABLE

Parts No.	Nomenclature
M9-001	Deck Panel
002	Knob, Track Selector Control
002a	Screw, Retaining Track Selector Control Knob
003	Head Cover (Main)
004	Head Cover (Sub)
005	Base, Head Cover
006a	Capstan Rest
006b	Capstan Holder
007a	Top Plate, Tape Guide
007b	Table, Tape Guide
007c	Bearing, Tape Guide
007d	Bottom Plate, Tape Guide
008	Tape Cleaner, Complete
008a	Felt, Tape Cleaner
009a	Prop, Head Cover
009b	Prop B, Head Cover
009c	Prop C, Head Cover
DECK FRAME	
010	Deck Frame
011	Head Assembly, Complete
011a	Erase Head
011b	Record/Playback Head
011c	Bias Head
011d	μ Spring, D
011e	Tape Guide (No. 17)
011f	Tape Guide (N-3)
011g	Tape Guide (N-2)
011h	Table, Head
011i	4T Cam
011j	Gear B, Head
011k	Spring, Field Table
011l	Holder, Spring
011m	Nut B, Head Lever
011n	Up-Down Table, Field
011o	Table, Field
011p	Spring, Field Table
011q	Micro Angle Table
011r	4T Shaft
011s	Upper Plate, Head
011t	Screw, Angle Adjustment
011u	Plate, Retaining Erase Head
011v	Plate, Retaining Record/Playback Head
011w	Side Plate, Bias Head
011x	Rotary Switch
011y	Gear A, Head
011z	4T Switch Table
012a	Shifter Metal
012b	Shifter Lever C, with Pin
012c	Shifter Lever B
013	Tape Counter, Complete
013a	Pulley, Counter

Parts No.	Nomenclature
M9-013b	Belt, Counter
014	Supply Reel Assembly, Complete
014a	Retainer, Reel
014b	Reel Plate, Assembly
014c	Rubber Ring
014d	Rewind Pulley
014e	Spring G (Left)
014f	Washer
014g	Thrust Washer Pin, Reel
014h	Take-up Roller, C
014i	Holder, Reel (Star Type Spring)
014j	Nylon Washer
014k	Washer
014l	Washer
014m	Thrust Washer Pin, Reel
014n	Washer
014o	Washer
014p	Metal Fitting, Reel
014q	Holder, Reel (Star Type Spring)
014r	Washer
014s	Washer Pin
014t	Pulley B2, Reel
014u	Screw, without Head 4 x 7
014v	Pulley C, Reel
014w	Screw Flat 3 x 6
015	Take-up Reel Assembly, Complete
015a	Take-up Roller, A
015b	Spring G (Right)
015c	Take-up Roller, D
015d	Spring F3
015e	Washer
015f	Washer
015g	Set Sleeve
015h	Screw, without Head 3 x 3.2
015i	Nylon Tube
016a	AS Lever, Complete
016b	Spring, AS Lever
016c	Plate, AS Lever (with Prop)
017a	Table, Eccentric Gear
017b	Eccentric Gear
017c	Stopper, Gear
017d	Spring, Stopper
017e	Lever, Automatic Switch
017f	Washer
018a	Instant Stop Lever A, with Instant Stop Lever B
018b	Spring, Instant Stop Lever
018c	Stopper, Instant Stop Lever
018d	Holder B, Instant Stop Lever
018e	Screw, Retaining Instant Stop Lever
018f	Lever, Shut-off
019a	Recording Safety Button
019b	Cam Stopper
019c	Fiber, Cam Stopper
019d	Insulator Plate, Cam Stopper
020a	Pinch Wheel

Parts No.	Nomenclature
M9-020b	Metal Cap, Pinch Wheel
020c	Screw, Pinch Wheel
020d	Lever, Pinch Wheel
020e	Shaft C, Pinch Wheel
020f	Spring, Pinch Wheel
020g	Shaft A, Cam Roller
020h	Cam Roller, B
021a	Lever, Take-up Brake Roller
021b	Rubber (Small), Brake
021c	Screw, Brake Roller
021d	Shaft, Brake Lever
022a	Lever, Supply Brake Roller
022b	Rubber (Large), Brake
022c	Screw, Brake Roller
022d	Shaft, Brake Lever
023a	6P Slide Switch ESS-22C-NB (Automatic Switch)
023b	Plate, Automatic Switch
023c	Safety Lever, A
023d	Safety Lever, B
023e	Prop, Safety Lever
024a	Speed Change Switch ESS-22C-NC
024b	Table, Lever FB
024c	Spring, Lever FB
025	Idler Wheel
026	Internal Wheel
027a	Lever, A (with Lever E)
027b	Shaft, Lever A
027c	Spring, D
028a	Lever, B (with Lever D)
028b	Cam Roller, A
028c	Cam Roller, B
028d	Spring, B
029a	Lever, C3
029b	Spring, D
030a	Lever, G (with Lever H-D)
030b	Metal, Lever G
030c	Shaft B, Idler
030d	Spring, Lever H-D
031a	Lever, K
031b	Screw
031c	Torsion Spring, D
031d	Bush
032a	Lever, FA
032b	Cam Roller, A
032c	Prop, Lever FA
033	Lever, F (for Motor)
034	Field Lever, A
035	Field Lever, B

Parts No.	Nomenclature
M9-036	Field Lever, D
037	Field Lever, E
038a	Start Lever A, with Start Lever B
038b	Start Button
039a	Prop, Panel
039b	Prop C, Head
040	Holder B, Spring
041	Pin B, Spring
042	Stopper C, Lever G
043	Hum Bucking Coil
044	Cycle Change Switch
045	Micro Switch V-1A
046	3P Lug Plate
047a	Lever, Belt Change
047b	Stopper, Belt Change Lever
047c	Spring, Belt Change Lever
047d	Spring B, Belt Change Lever
048	Voltage Adjustment Coil
049	Shift Lever
050a	Supporting Prop
050b	Nut, Prop

MOTOR BLOCK

051	Motor, Complete
051a	Screw
051b	Stepped Pulley
051c	Motor Pulley
051d	Holder L, Motor
051e	Motor
051f	Motor Fan
051g	Screw, without Head
051h	Prop A, Motor
051i	Prop B, Motor
051j	MP Condenser $2\mu+0.8$ 250 VAC
051k	Holder, MP Condenser
051l	+Screw Flat Mould 4 x 50
051m	External Shield Plate, Motor
052a	MP Condenser 1μ 220 VAC
052b	5P Lug Plate

FLYWHEEL

054	Flywheel, Complete
054a	Capstan
054b	Main Metal Cap, B
054c	Washer Pin

Parts No.	Nomenclature
M9-054d	Main Metal Case, B
054e	Spring, Main Metal
054f	Nylon Washer
054g	Main Shaft C
054i	4 mm Ball Bearing
054j	Nylon Plate
054k	Plate, Flywheel
054l	Spring Washer
054m	Spring Washer
054n	Nut
054o	Screw
054p	Washer
054q	Prop B, Flywheel
054r	Prop A, Flywheel

SWITCH BLOCK

055a	Knob, Record/Play & Rewind Fast Forward
055b	Screw
055c	Cam, A-2
055d	Plate, Cam Roller
055e	Cam Roller
055f	Cam, B
055g	Switch Table, A
055h	Spring, E
055i	Lever, I
055j	Screw
055k	4 mm Nut
055l	Rotary Switch S-143
055m	Fast/Forward Rewind Shaft
055n	Plate, Cam
055o	Spring, K
055p	Cam, C
055q	+Screw Flat Mould 4 x 6
055r	Switch Table, B-2
055s	Washer
055t	Cam, Amplifier Switch
055u	Washer Pin
055v	Prop, Record Lever

056a	Switch Lever, A
056b	Switch Lever, B
056c	Cam Roller, A
056d	Spring

057a	5P Lug Plate
057b	Resistor

CASE BLOCK

058	Case, Complete
058a	Case
059	Rubber Foot
060	Ventilator
061	Speaker
062	Reflector, Speaker
063	Escutcheon

Parts No. Nomenclature

AMPLIFIER FRONT BLOCK

M9-064a Amplifier Panel, with Prop
 064b Name Plate, Panel
 064c AR Chassis
 064d Prop, AR Chassis

065a Lug plate KP1L3
 065b Lug Plate KP2L2

066 VU Meter

067a 2-pole E Jack (Mic. Jack)
 067b 3-pole E Jack (Headphone Jack)

068a Seesaw Switch (SW6) (Power SW)
 068b Seesaw Switch (SW3, SW4) (Function SW & Bass/Flat SW)
 068c Rotary Switch SR 26N-133 (Recording Mode SW)
 068d Sound on Sound Arm

069a Variable Resistor V24N-50KA (VR1)
 069b Variable Resistor D24N-100B, 10 KA (VR2a, b)

070 Knob, Amplifier Switch

071a Resistor $\frac{1}{4}$ P 220K Ω (K) (R2)
 071b Resistor $\frac{1}{4}$ P 100K Ω (K)
 071c Resistor $\frac{1}{4}$ P 4.7K Ω (K) (R3)
 071d Resistor $\frac{1}{4}$ P 680 Ω (K) (R1)
 071e Resistor $\frac{1}{4}$ P 47 Ω (K) (R8)
 071f Resistor $\frac{1}{4}$ P 33K Ω (K) (R9)
 071g Resistor $\frac{1}{4}$ P 15K Ω (K) (R5)

072a Condenser 0.001 (K) 50WV (C2)
 072b Condenser 0.0022 (K) 50WV (C3)
 072c Condenser 0.0033 (K) 50WV (C1)

073a Sub Amplifier Panel A
 073b Sub Amplifier Panel B

JACK PLATE BLOCK

074 Jack Plate

075a 4P Holder
 075b 4P Jack

076a Lug Plate KP1L1
 076b Lug Plate KP1L2
 076c Lug Plate KPL5L
 076d Lug Plate VB 1L1

077a DIN Jack
 077b 2-pole E Jack

078 Name Plate, Jack

079 Connector US Plug

080a Resistor $\frac{1}{4}$ P 22K Ω (K)
 080b Resistor $\frac{1}{4}$ P 10K Ω (K)
 080c Resistor 3W 270 Ω (K) (R10)

081a Condenser 2,000 μ 25WV (C7, C8)
 081b Condenser 1,000 μ 35WV (C6)

Parts No. Nomenclature

M9-082 Chassis, Main Amplifier

083a 10P Multi-Jack
 083b Plate, 10P Multi-Jack

084a Resistor 15W 33 Ω
 084b Resistor $\frac{1}{4}$ P 150 Ω (K) (R11)
 084c Wired Resistor 2W 2.7 Ω
 084d Compound Body AK-16

085a Lug Plate KP1L1
 085b Lug Plate KP2L2

CHASSIS BLOCK

086 Chassis, Pre-Amplifier

087 Prop, 3R Panel

088a Link Lever, with Pin
 088b Screw
 088c Nut
 088d Spring D

089a Recording Lever
 089b Screw
 089c Amplifier Lever Prop, with Pin
 089d Spring, Recording Lever

090a Lug Plate KP1L
 090b Lug Plate KP2L2

091 Rotary Switch SR-27N- 2-4-3

092 Variable Resistor 18 ϕ 2KB (VR3)

093a Resistor $\frac{1}{4}$ P 15K Ω (K) (R4)
 093b Resistor 1P 1.8K Ω (K) (R7)
 093c Resistor $\frac{1}{4}$ P 8.2K Ω (K) (R6)

094a Condenser 500 μ 25V (C5)
 094b Condenser 50 μ 50V (C4)

ASSEMBLY BLOCK

095 Side Plate

096a Knob, Volume
 096b Knob, Tereble
 096c Knob, Record Level

097a Holder, Cord
 097b Clamp

098 Shield, Pre-Amplifier

099 Speed Nut

SWITCH BLOCK CARD

100 Switch Block Card, Complete

101 Printed Circuit Plate, Switch Block

102 Slide Switch SL-62

Parts No.	Nomenclature
M9-103a	10P Multi-Jack (Special)
103b	Holder E, 10P Multi-Jack
104a	Resistor ¼P 100KΩ (K) (R101)
104b	Resistor ¼P 5.6KΩ (J) (R102)
104c	Resistor ¼P 22KΩ (K) (R103)
104d	Resistor ¼P 22KΩ (K) (R104)
104e	Resistor ¼P 33KΩ (K) (R105)
104f	Resistor ¼P 22KΩ (K) (R106)
104g	Resistor ¼P 10KΩ (K) (R107)
104h	Resistor ¼P 22KΩ (K) (R108)
104i	Resistor ¼P 1KΩ (K) (R109)
104j	Resistor ¼P 180KΩ (K) (R110)
104k	Resistor ¼P 10KΩ (K) (R111)
104l	Resistor ¼P 15KΩ (K) (R112)
105a	Condenser 220P 35V (K) (C101)
105b	Condenser 330P 35V (K) (C102)
105c	Condenser 0.012 50V (J) (C103)
105d	Condenser 0.15 35V (K) (C104)
105e	Condenser 0.015 50V (K) (C105)
105f	Condenser 0.01 50V (K) (C106)
105g	Condenser 0.056 50V (K) (C107)
105h	Condenser 3μ 25V (C108)
105i	Condenser 0.022 50V (K) (C109)
105j	Condenser 10μ 6V (C110)
106	Transistor 2SC-458 B (TR101)
107	Inductance 302J 3mH±5% (L101)
108	Switch Shield
109a	Main Lever
109b	Sub Lever
110a	Screw
110b	Screw
111	4P Plug
112	Pre-Amplifier Card, Complete (CD512)
113	Printed Circuit Plate, Pre-Amplifier
114a	Transistor 2SC 650 (A) (Tr 1, 2)
114b	Transistor 2SC 281 (B) (Tr 3, 4)
115a	Resistor ¼P 220Ω (K) (R205)
115b	Resistor ¼P 3.3KΩ (K) (R204)
115c	Resistor ¼P 4.7KΩ (K) (R207, 211)
115d	Resistor ¼P 22KΩ (K) (R206)
115e	Resistor ¼P 68KΩ (J) (R217)
115f	Resistor ¼P 100KΩ (J) (R201, 202, 208)
115g	Resistor ¼P 120KΩ (J) (R209)
115h	Resistor ¼P 150KΩ (K) (R203)
115i	Resistor ¼P 100Ω (K) (R214)
115j	Resistor ¼P 330Ω (K) (R216)
115k	Resistor ¼P 470Ω (K) (R213)
115l	Resistor ¼P 1.5KΩ (K) (R215)
115m	Resistor ¼P 10KΩ (K) (R210)
115n	Resistor ¼P 15KΩ (K) (R212)
116a	Condenser 100μ 3V (C208, 209)

Parts No.	Nomenclature
M9-116b	Condenser 10μ 10V (C201, 202, 204, 206)
116c	Condenser 10μ 25V (C212)
116d	Condenser 50μ 25V (C203)
116e	Condenser 330P 35V (C211)
116f	Condenser 220P 35V (C213)
116g	Condenser 0.01μ 50V (C205)
116h	Condenser 0.022μ 50V (C210)
116i	Condenser 1μ 10V (C207)
117	Variable Resistor 20KB (VR201)
118	Headphone Transformer 7K:8Ω (T201)
MAIN AMPLIFIER BLOCK CARD	
119	Main Amplifier Card, Complete
120	Printed Circuit Plate, Main Amplifier
121a	Transistor 2SC-372
121b	Transistor 2SC-367 (O)
122a	Resistor RF¼ 27KΩ (J) (R301)
122b	Resistor RF¼ 5.6KΩ (J) (R302)
122c	Resistor RF¼ 100Ω (K) (R303)
122d	Resistor RF¼ 3.9KΩ (K) (R304)
122e	Resistor RF¼ 1KΩ (K) (R305)
122f	Resistor RF¼ 1.8KΩ (K) (R306)
122g	Resistor RF¼ 1.6KΩ (J) (R307)
122h	Resistor RF1W 430Ω (J) (R308)
122i	Resistor RF¼ 56Ω (K) (R309)
122j	Resistor RF¼ 2.7KΩ (J) (R310)
122k	Resistor RF¼ 68KΩ (K) (R311)
122l	Resistor RF¼ 22KΩ (K) (R312)
122m	Resistor RF1W 430Ω (K) (R313)
122n	Resistor RF¼ 18Ω (K) (R314)
122o	Wired Resistor ½W 0.5Ω (K) (R315)
123a	Condenser 10μ 10V (C301)
123b	Condenser 680P 35V (K) (C302)
123c	Condenser 300μ 3V (C303)
123d	Condenser 300μ 10V (C304)
123e	Condenser 100μ 25V (C305)
123f	Condenser 500μ 3V (C306)
123g	Condenser 500μ 10V (C307)
123h	Condenser 0.022 50V (K) (C308)
124	Driver Transformer N28-696AT
125	Semi-fixed Resistor V-17K2-1B 100ΩB
126	Radiative Plate
127	Prop, Retaining Main Amplifier Card
128	Transistor 2SC-490
129	Thermister 22D47
130a	Fuse Holder, with Plate
130b	Fuse, 1A
OSCILLATOR BLOCK CARD	
131	Oscillator Block Card, Complete

Parts No.	Nomenclature
M9-132	Printed Circuit Plate, Oscillator
133	Oscillator Coil
134	Transistor 2SC-696 J L F
135a	Resistor RD1L 22 Ω (K) (R401)
135b	Resistor RD $\frac{1}{2}$ P 10 Ω (K) (R402)
135c	Resistor RD $\frac{1}{4}$ P 1K Ω (K) (R403)
135d	Resistor RD $\frac{1}{4}$ P 100 Ω (K) (R404)
136a	Condenser 100 μ 25V (C401)
136b	Condenser 100 μ 3V (C402)
136c	Condenser 0.047 35V (K) (C403)
136d	Condenser 0.068 35V (K) (C404)
136e	Condenser 9500 500V (J) (C405)
136f	Condenser 220P 500WV (K) (C406)
137	Plate B, Oscillator
138	Prop, Chassis

POWER BLOCK

139	Power Block, Complete
140	Chassis, Transformer
141a	Power Transformer (T-501)
141b	Shield Plate, Transformer
142a	Condenser 500 μ 50WV (C501)
142b	Condenser 500 μ 50WV (C502)
142c	Condenser 2000 μ 50WV (C503)
143	Lug Plate KP1L1
144a	Diode SPN-01
144b	Diode SW-05-01
145	Plate, Socket
146a	Post, Fuse
146b	Fuse, 2A
147	6P Slide Switch ESS-22C-NC (SW501)
148	Socket, Voltage Change
149	Rubber Bush
150	AC Cord
151	Plug S, Voltage Change
152a	UZ Socket (J502)
152b	US Socket (J503)
153a	Lug Plate KP1L1
153b	Diode SW-05-01

X. EXPLODED VIEW OF COMPONENT PARTS

FRONT PANEL

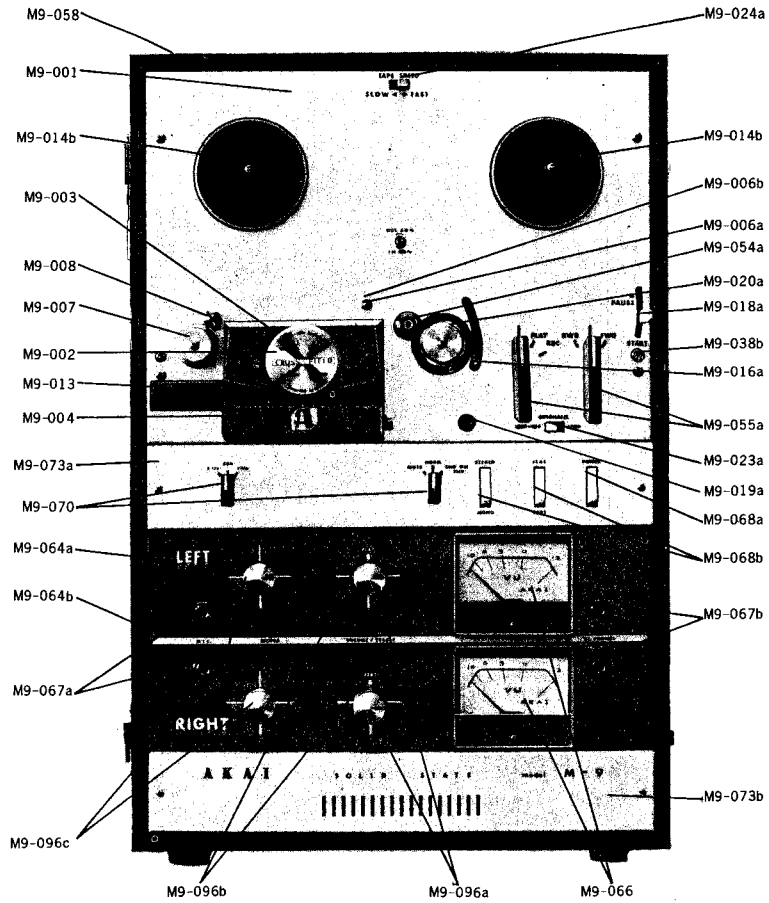

CASE

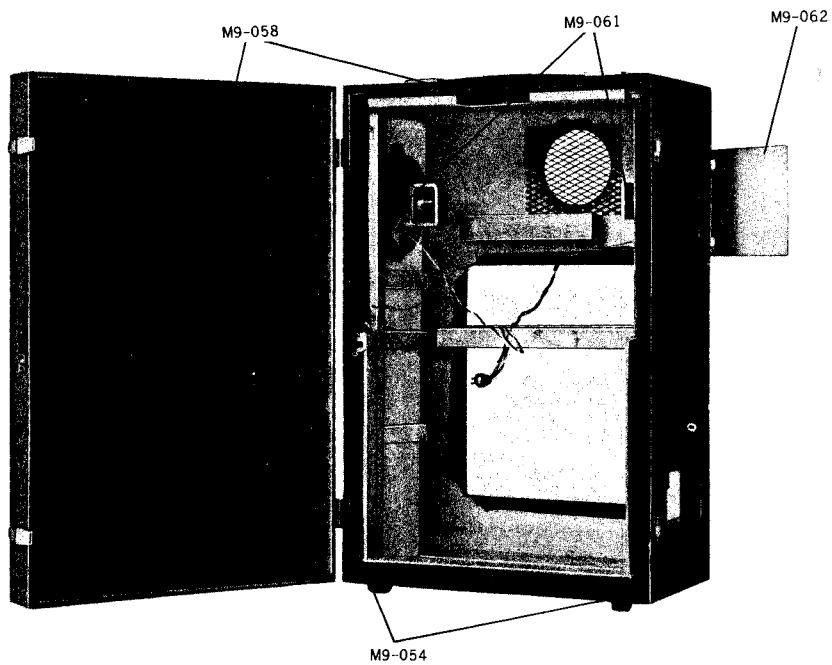

AMPLIFIER-1

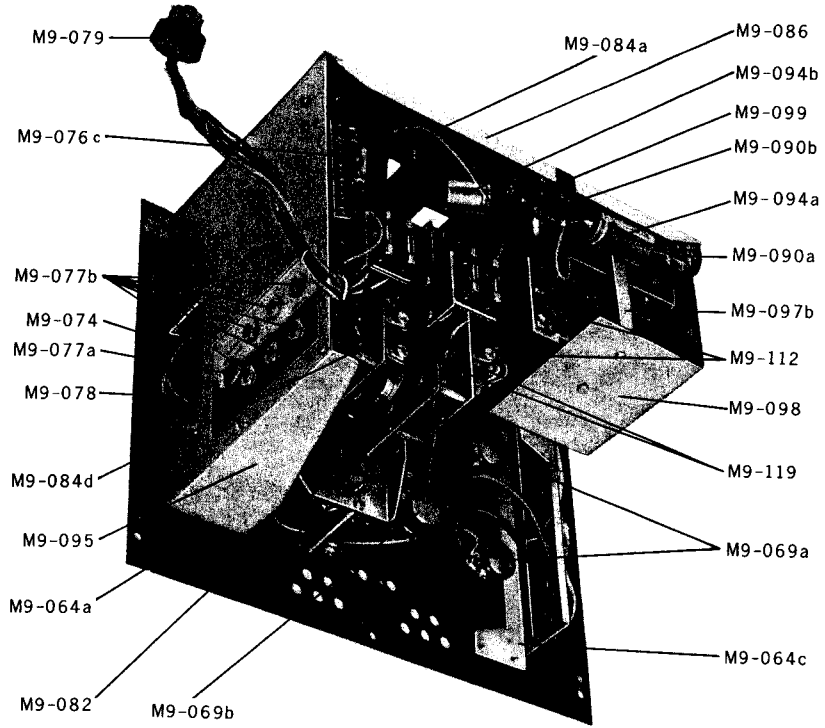

AMPLIFIER-2

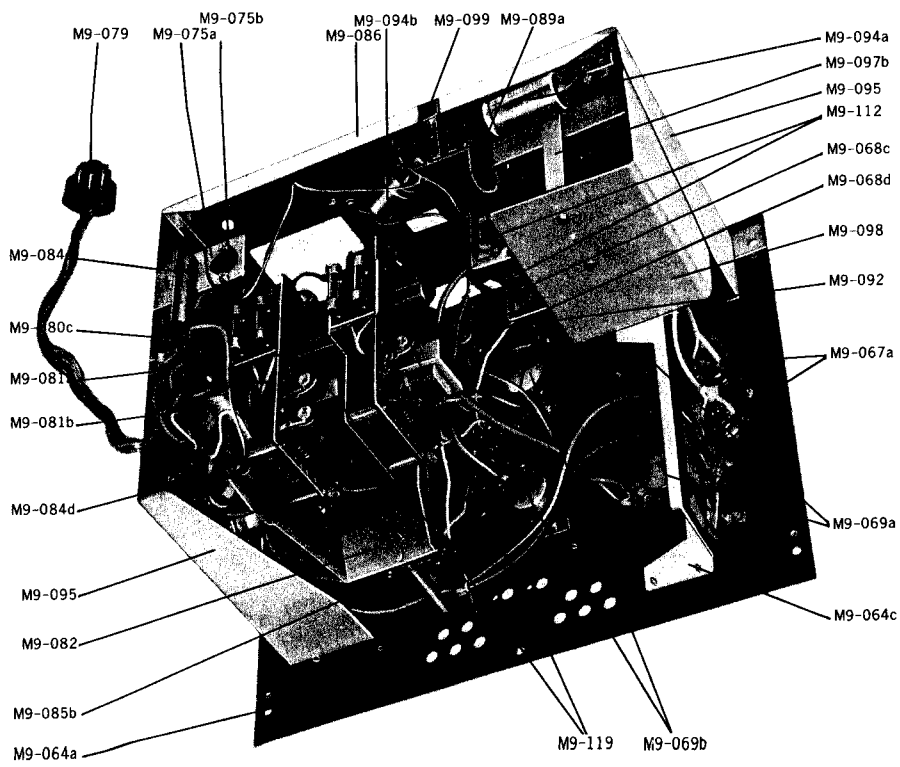

SWITCH BLOCK-1

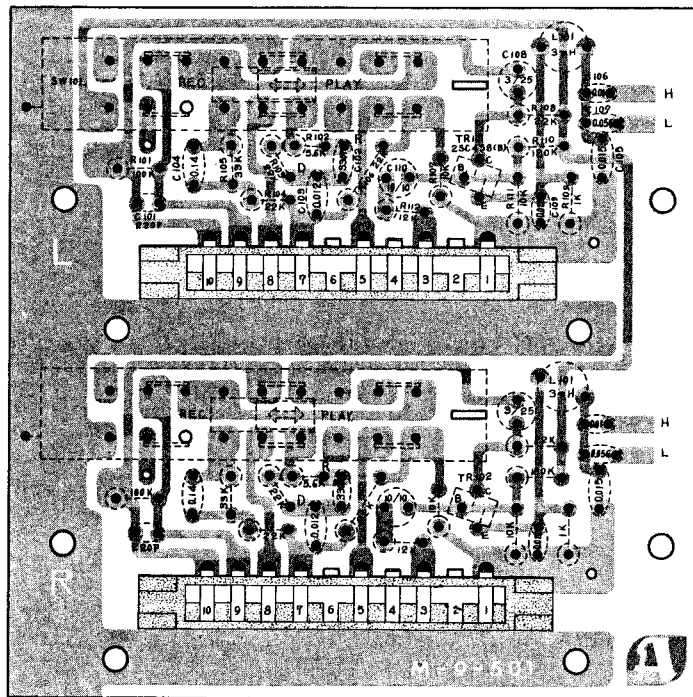
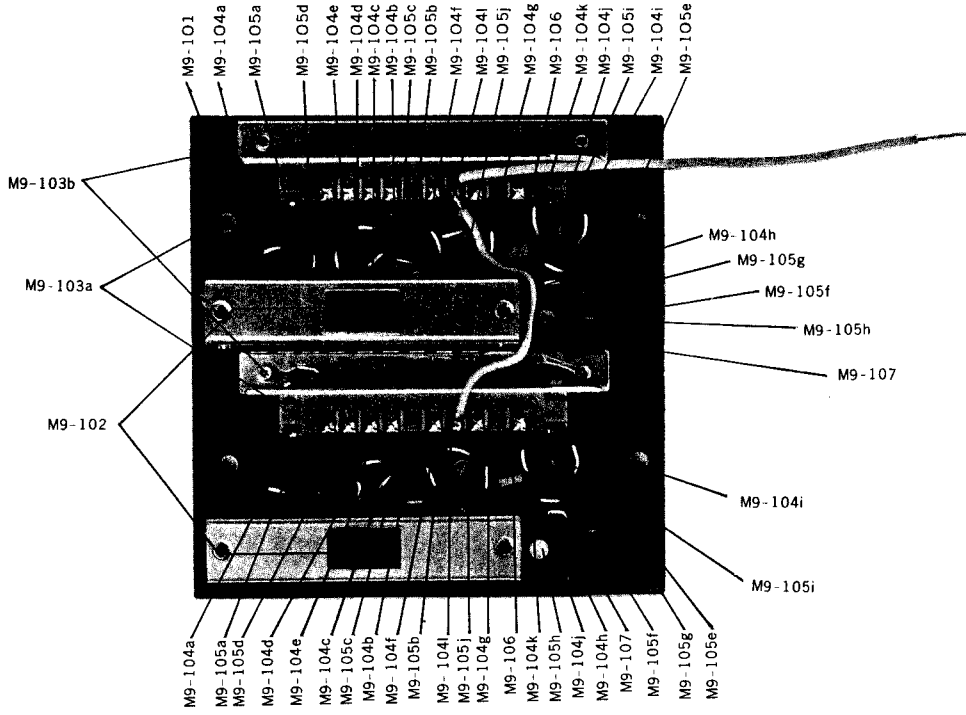

SWITCH BLOCK-2

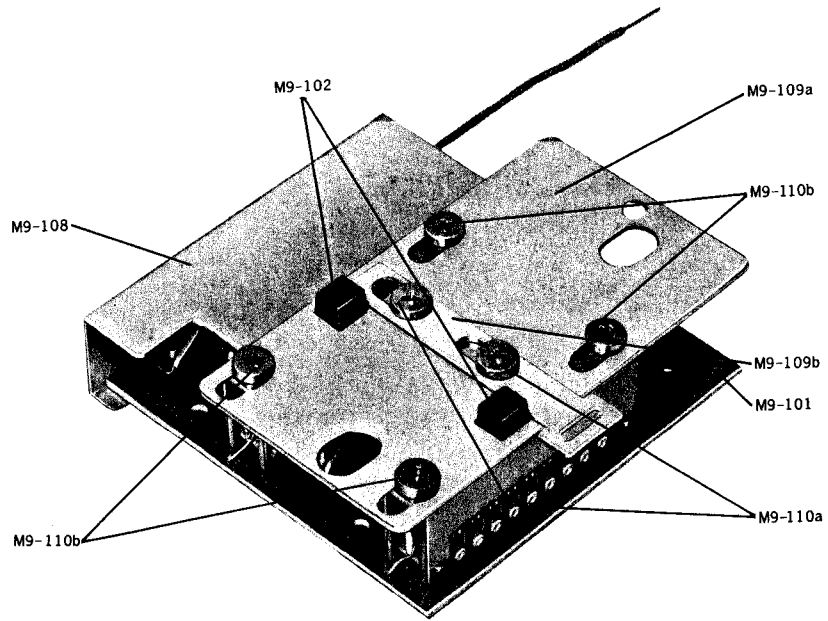

PRE-AMPLIFIER CARD

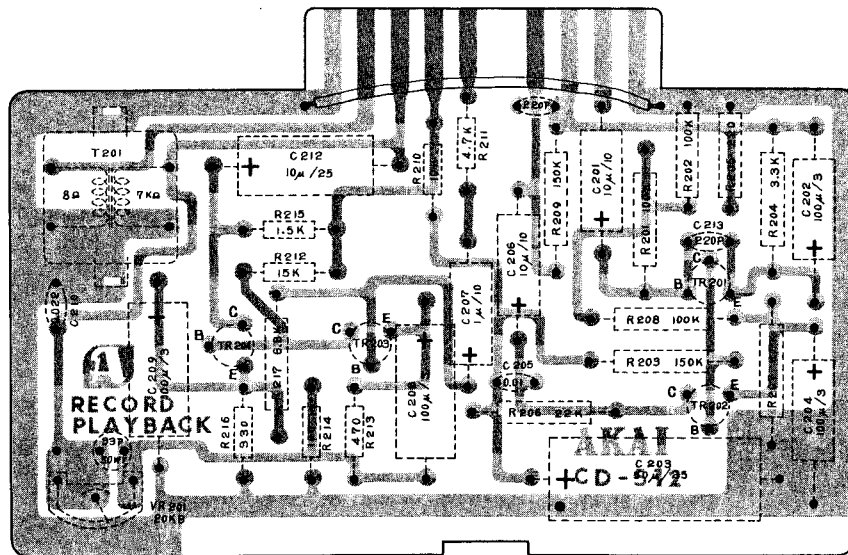
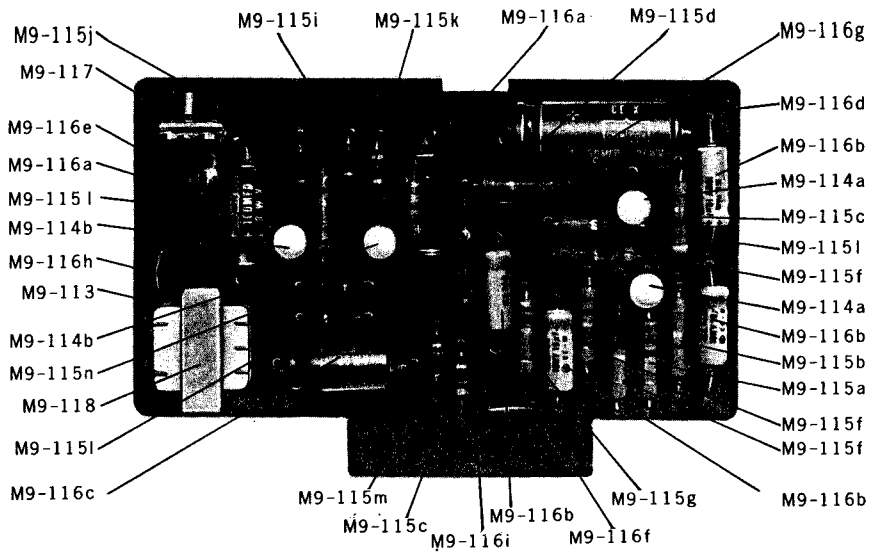

MAIN AMPLIFIER CARD

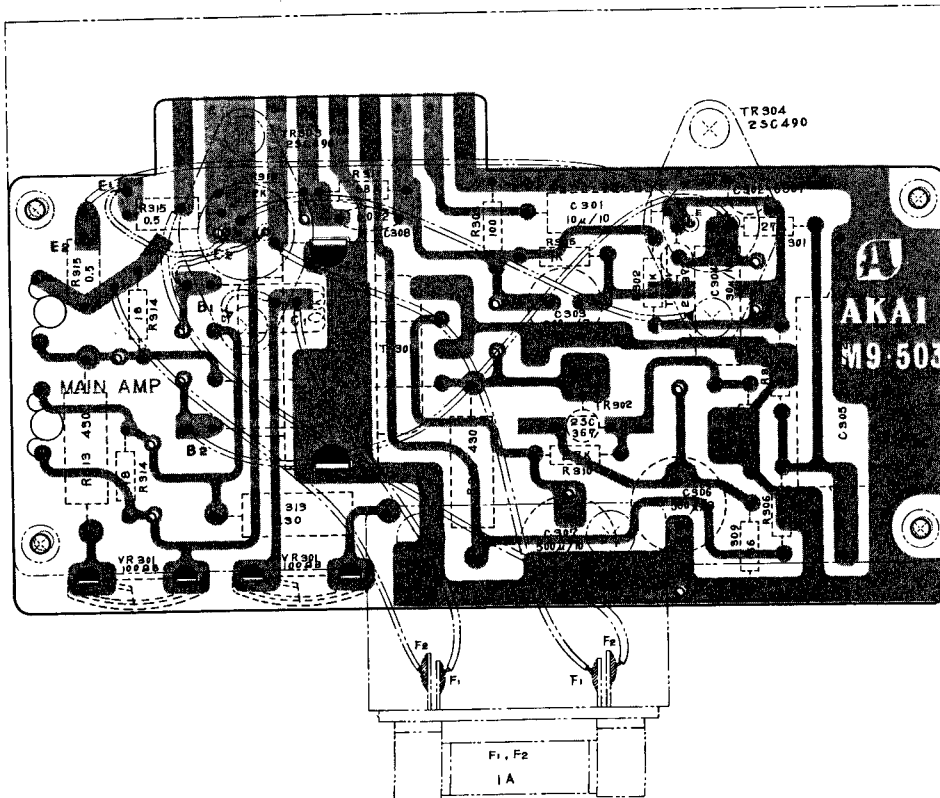
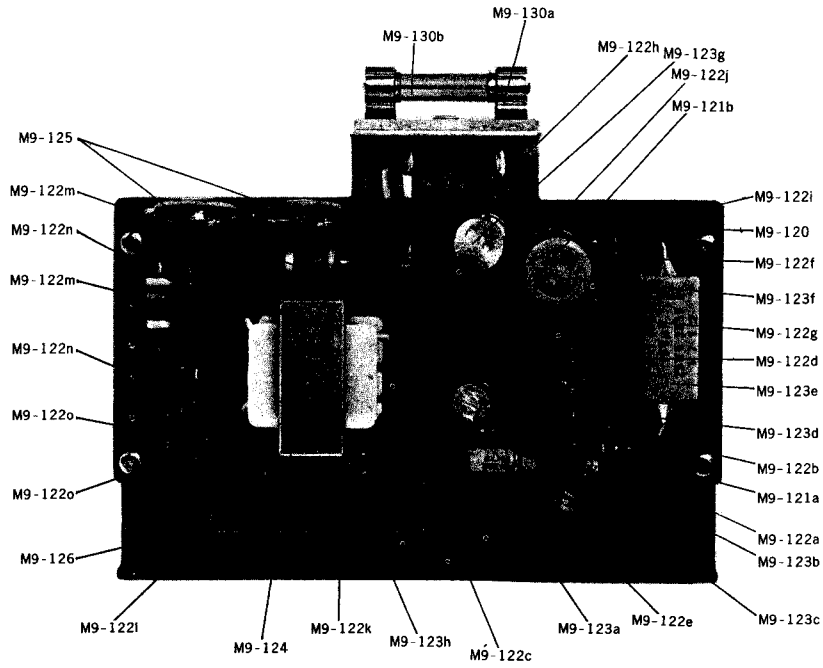

OSCILLATOR CARD

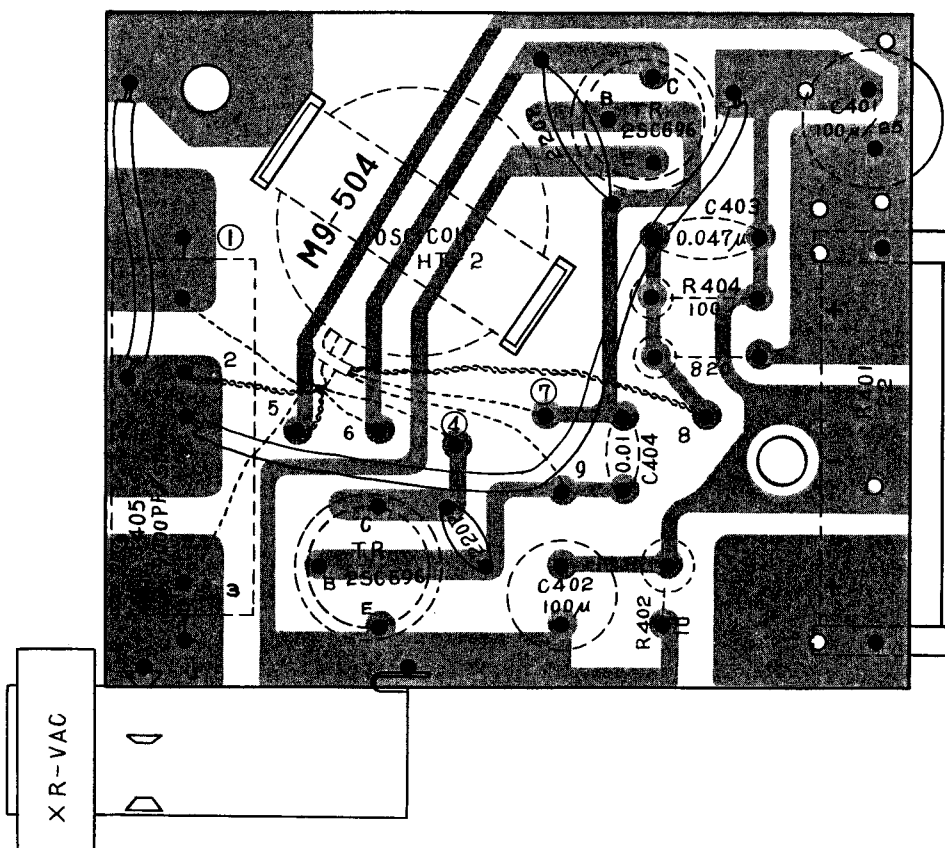
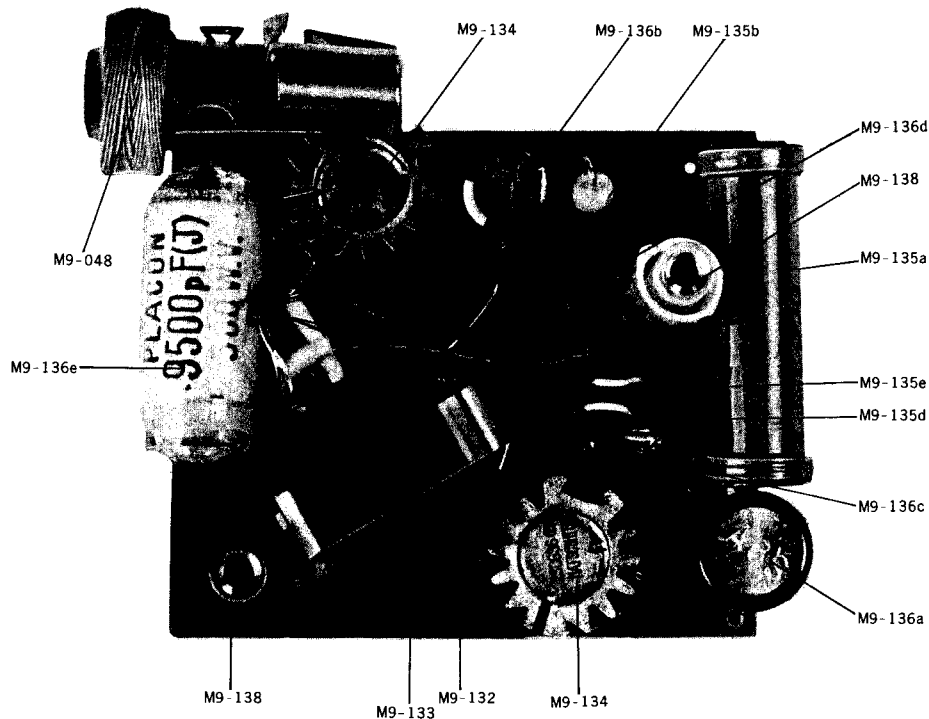

OSCILLATOR CARD BLOCK

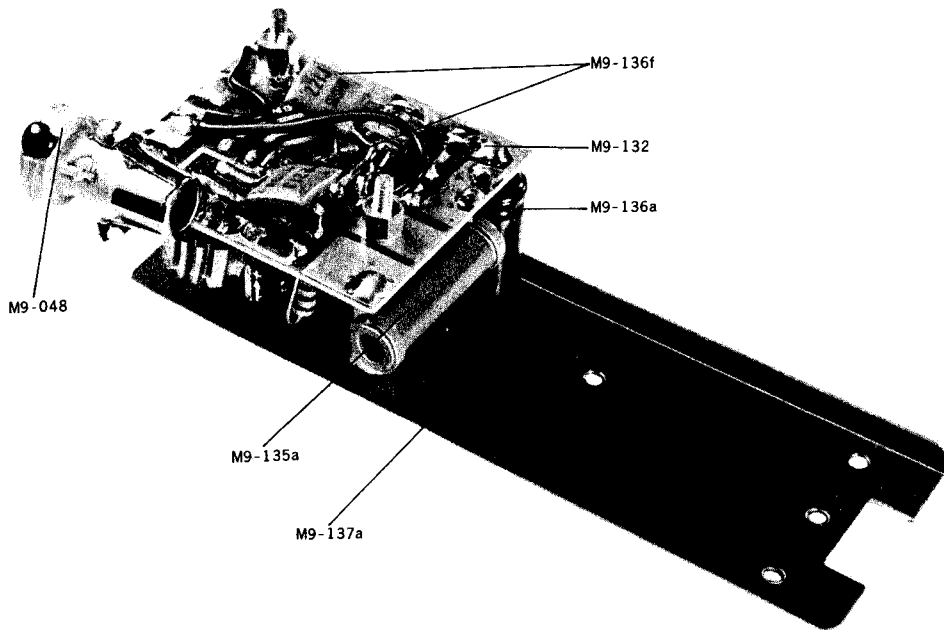

POWER BLOCK

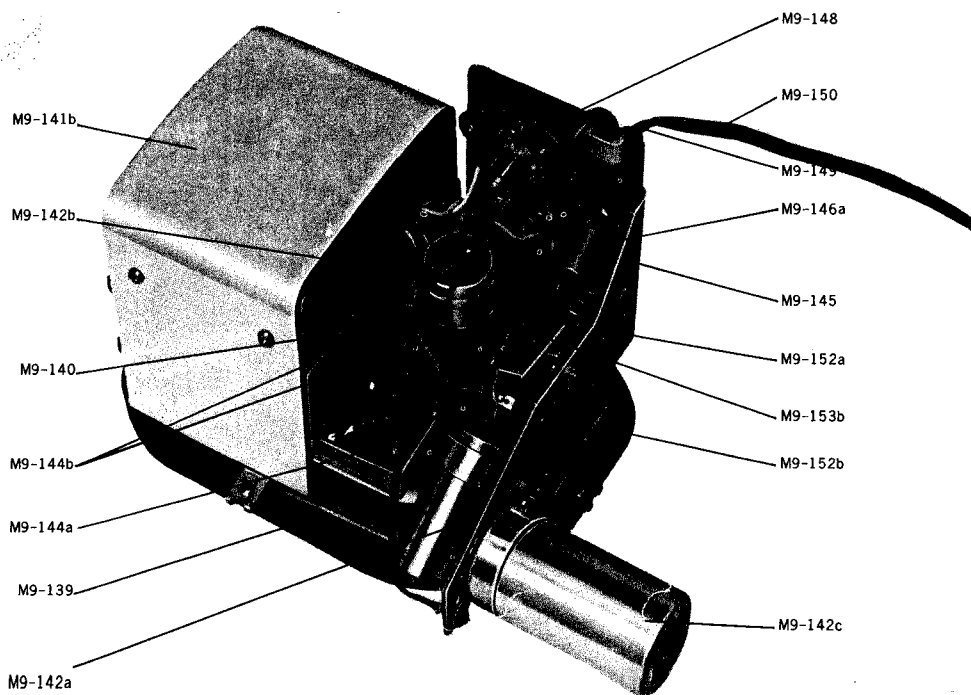

SECTION "A" TROUBLES WITH AMPLIFIER

1. Playback problems (Unit set in play position)

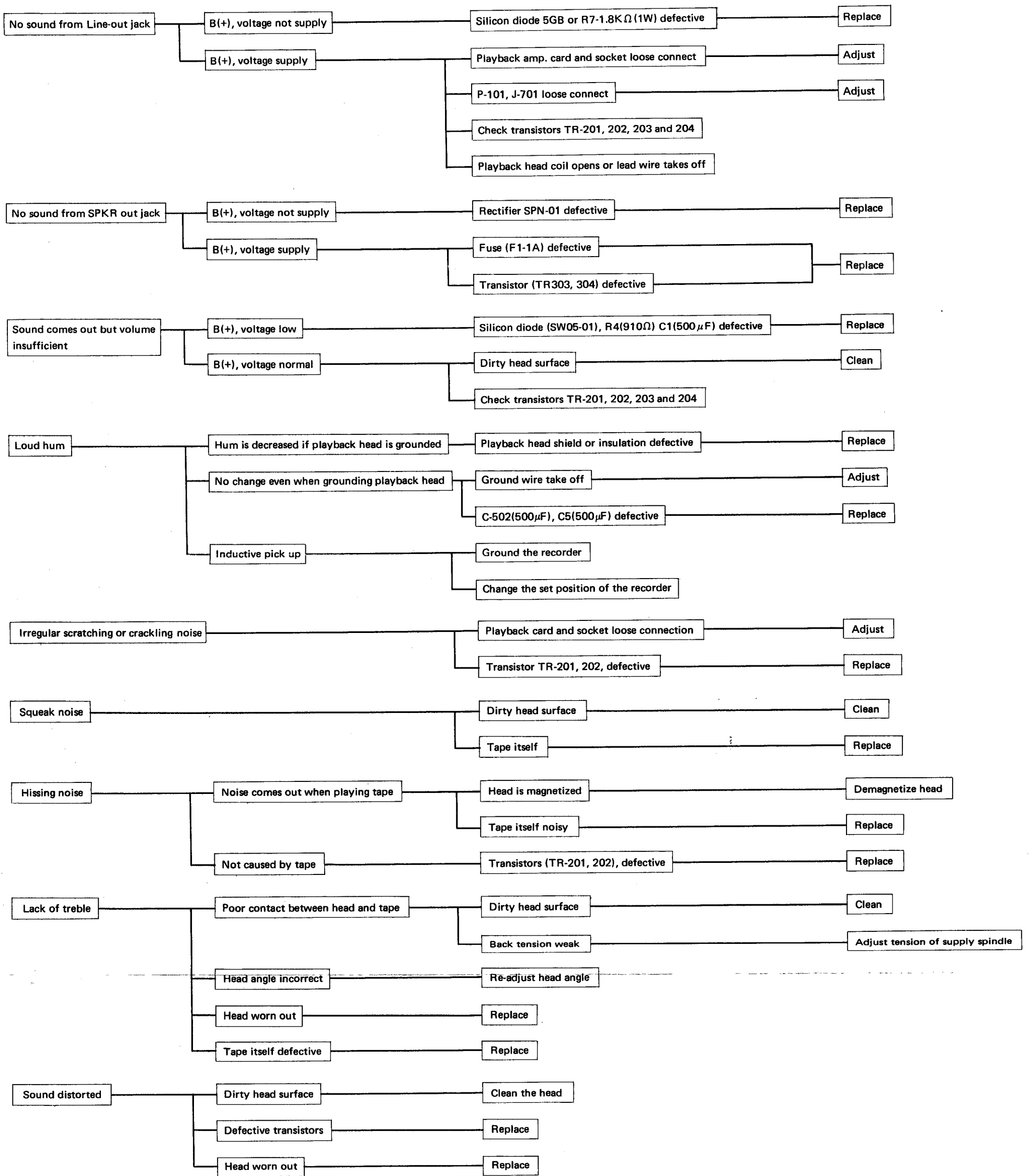

SECTION "B" TROUBLES WITH TAPE TRANSPORT MECHANISM

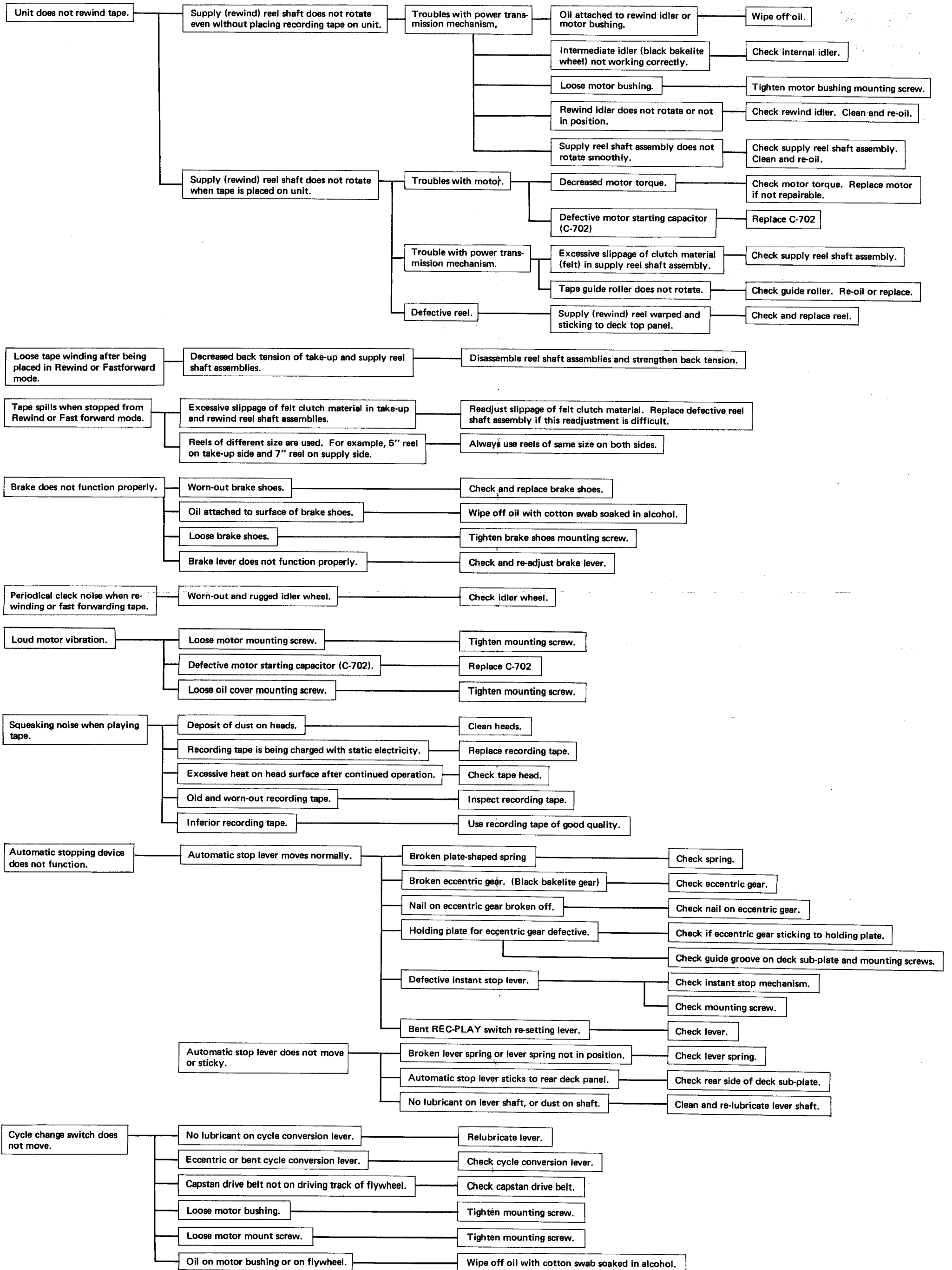

2. Recording problems

(Unit plays back pre-recorded tapes okay, but recording not satisfactory)

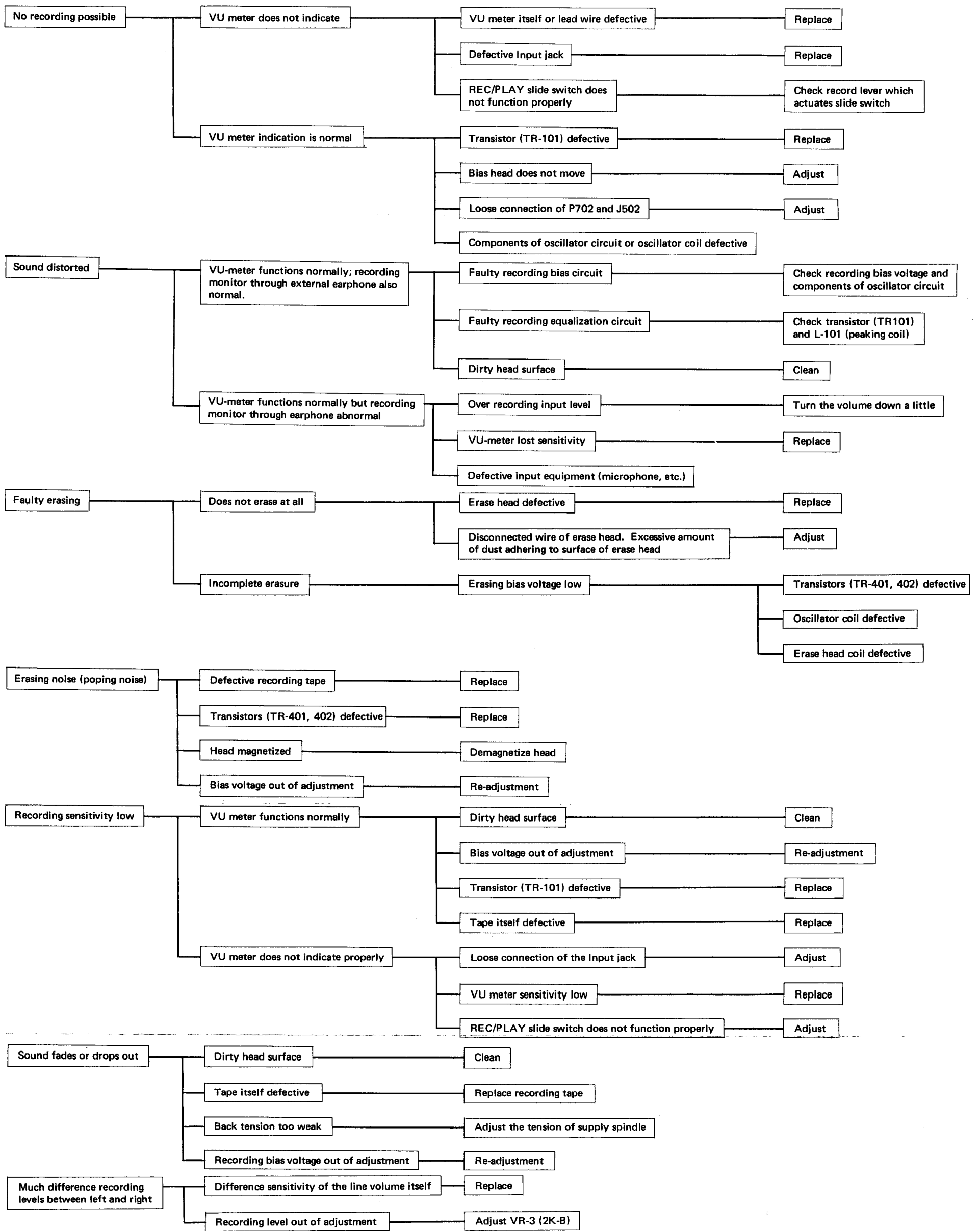

SECTION "B" TROUBLES WITH TAPE TRANSPORT MECHANISM

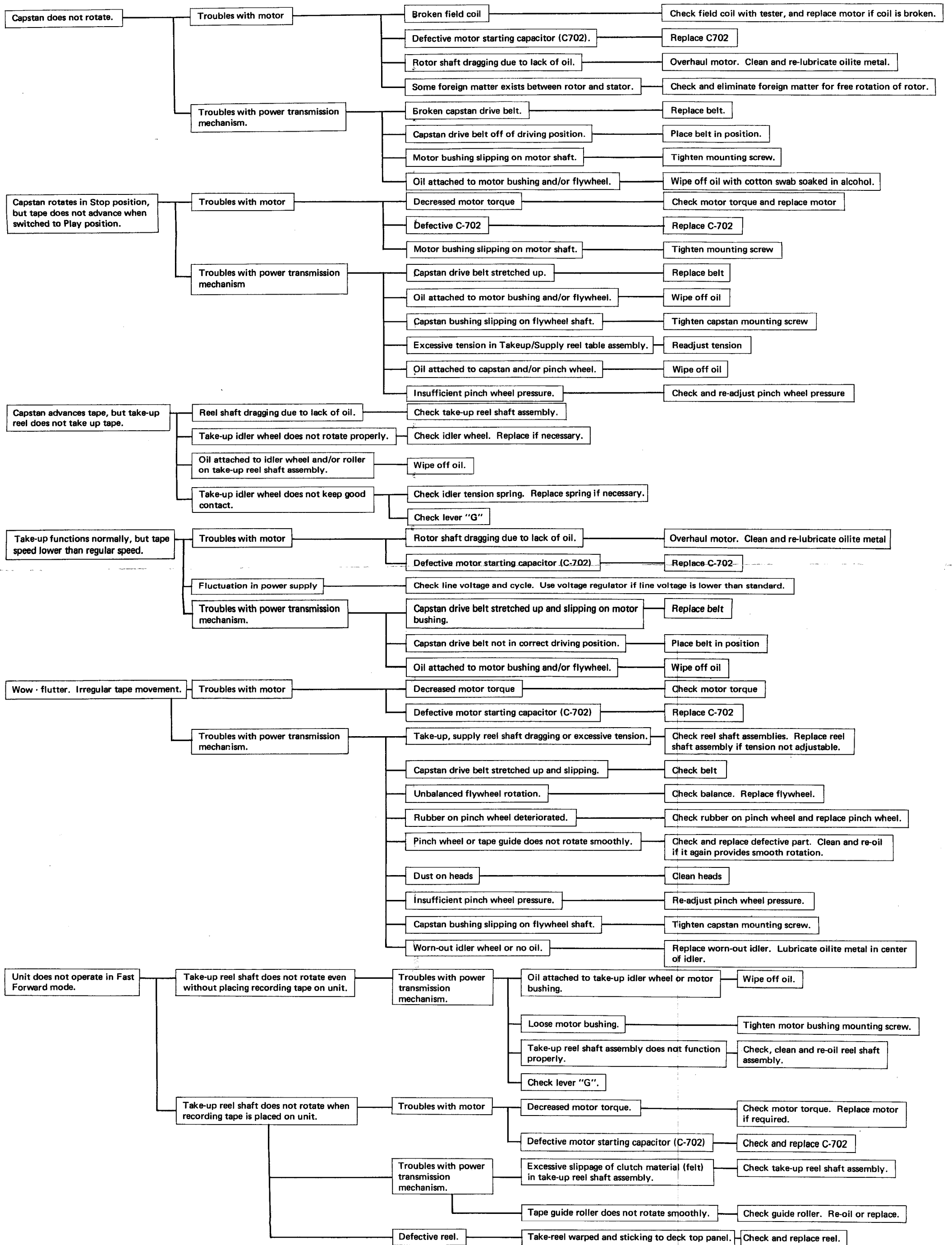

M-9.M-9DX.SCHEMATIC

4-TRACK CROSS FIELD HEAD ASSEMBLY NO.8

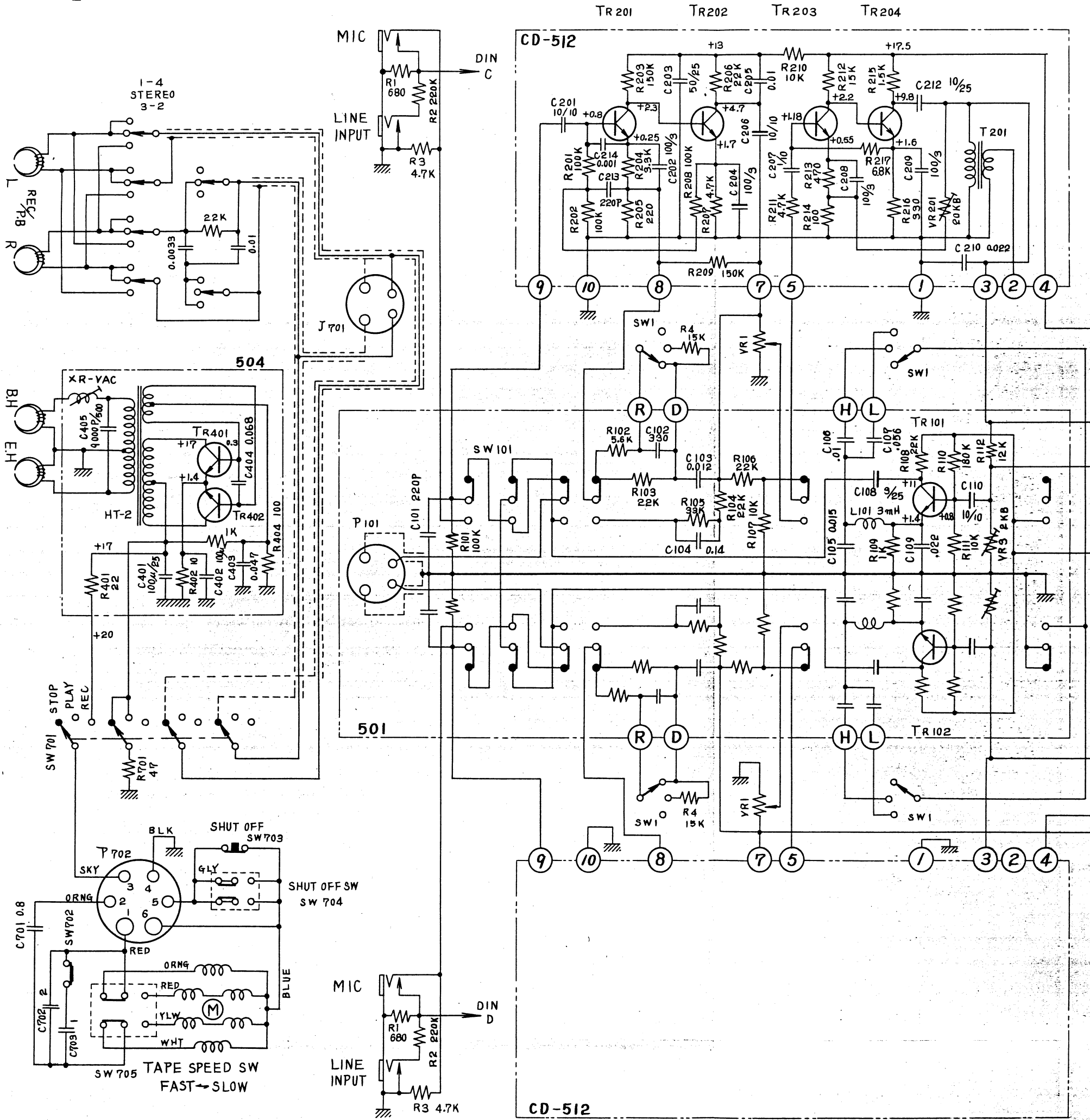

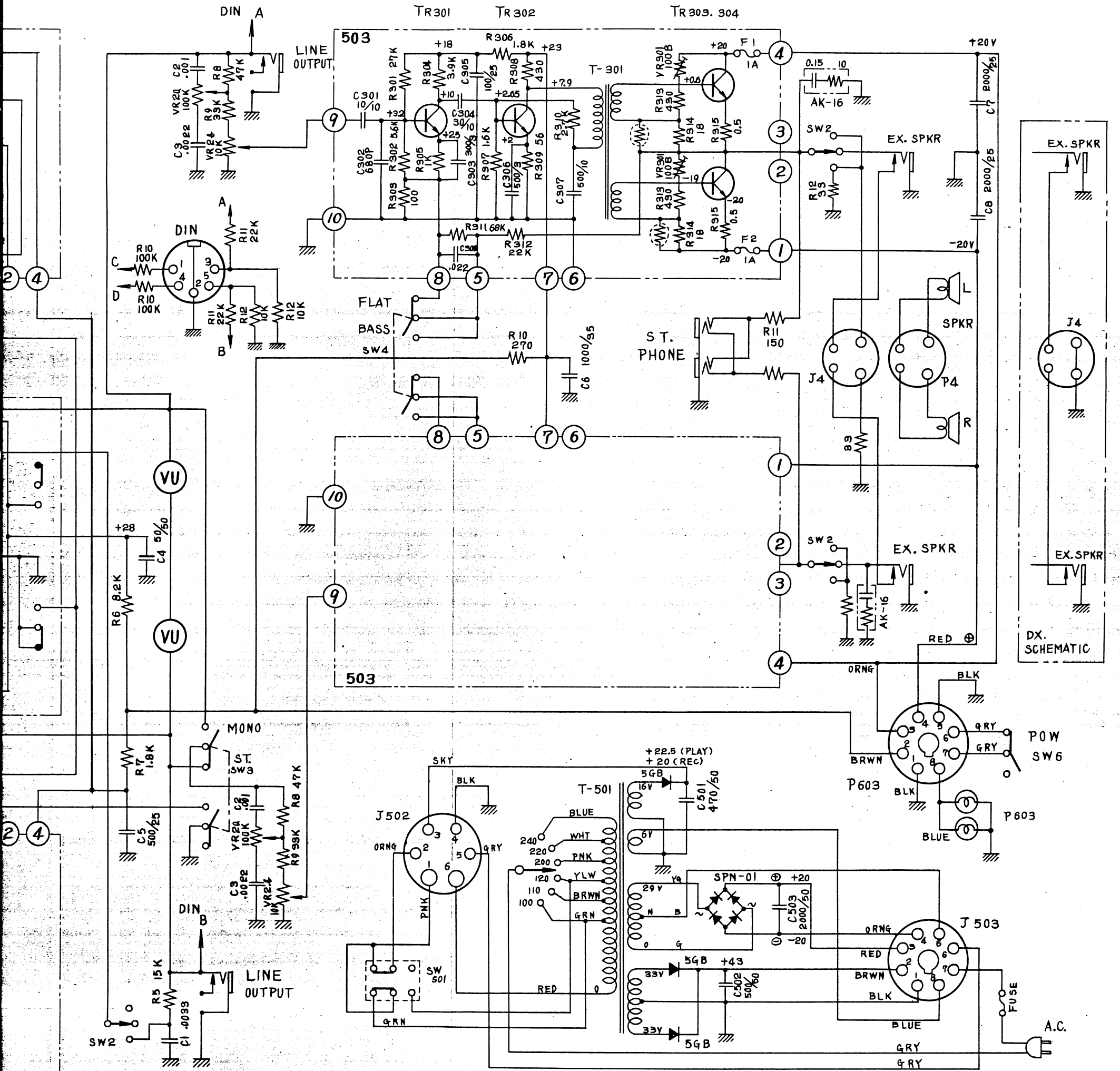

1342058.4

TR101, 102	2SC458(B)	2	TR301.	2SC372	2
TR201.	2SC650(A)	2	TR302	2SC367	2
TR202.	2SC649(B)	2	TR303,304	2SC400	4
TR203, 204	2SC281(B)	4	TR401, 402	2SC696(JXIX)	2

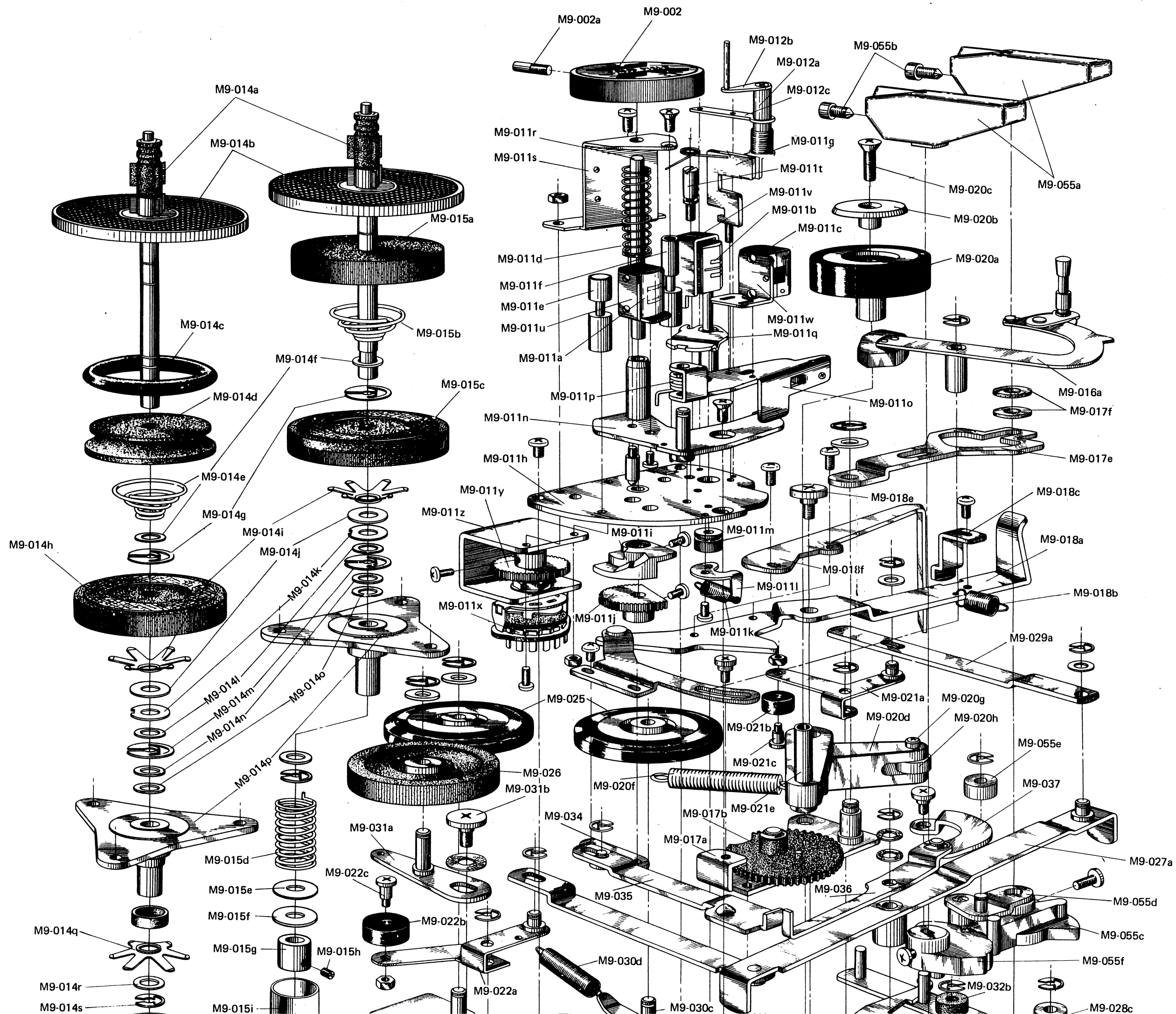

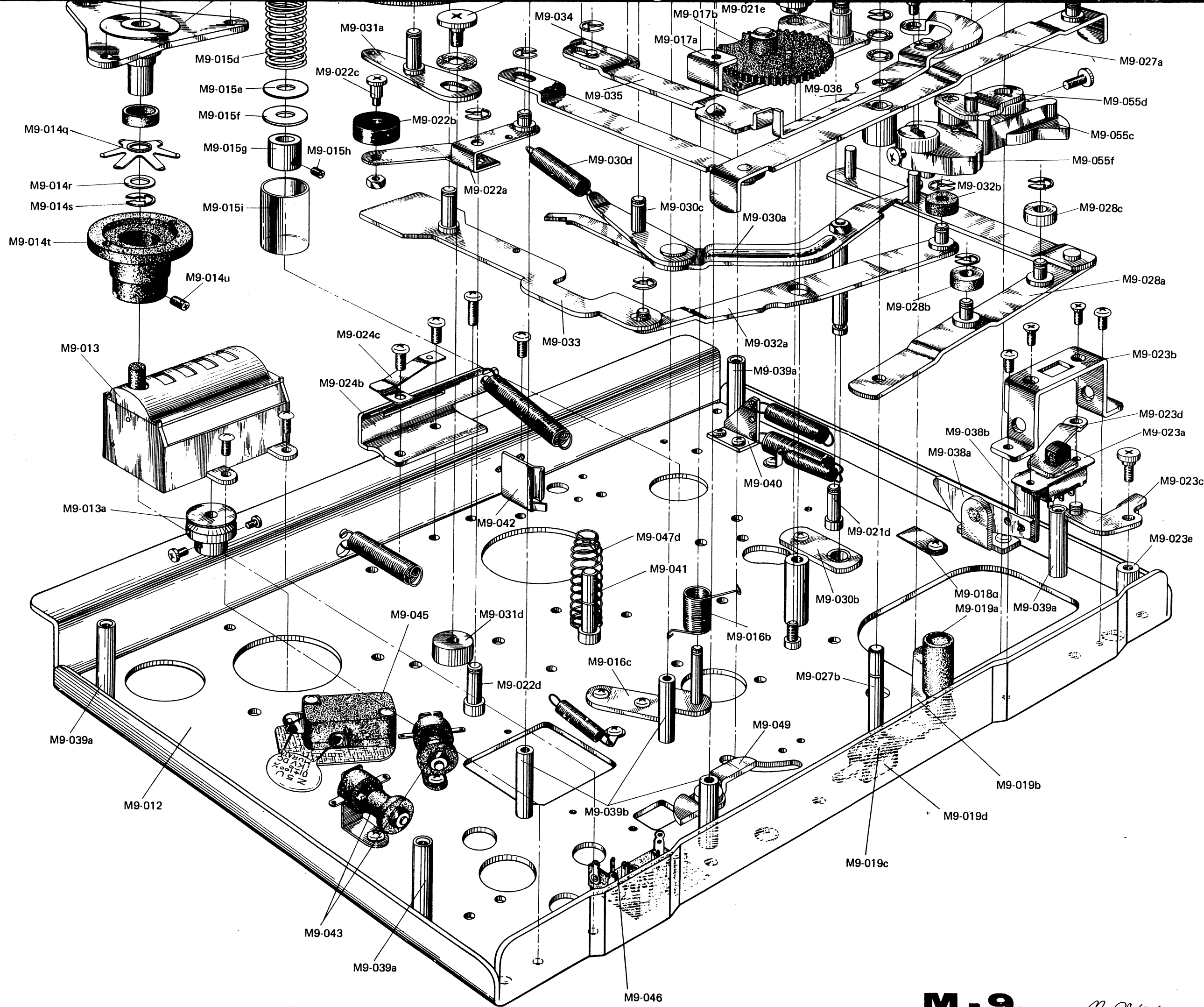

M-9

N. Detonick

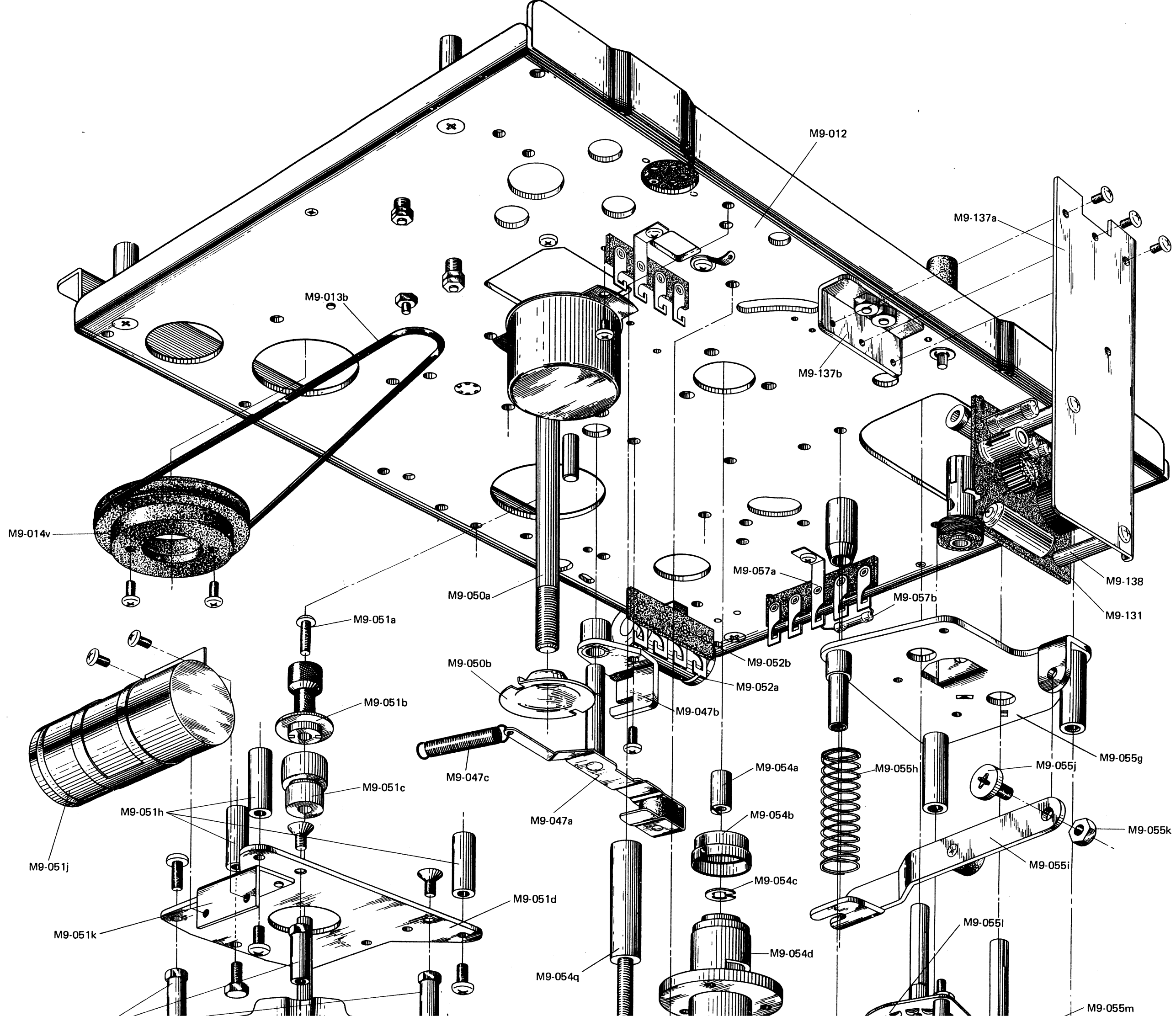

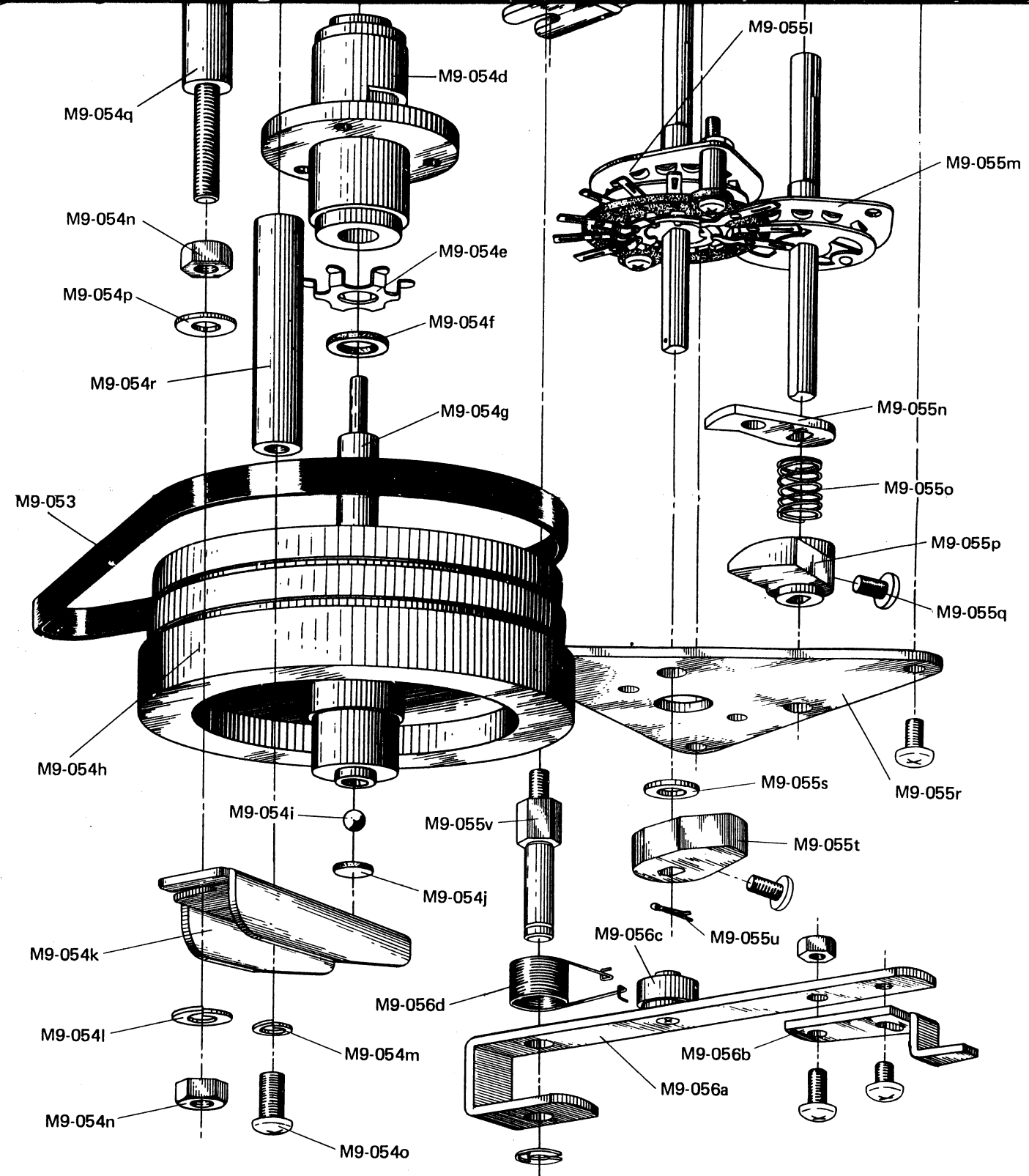
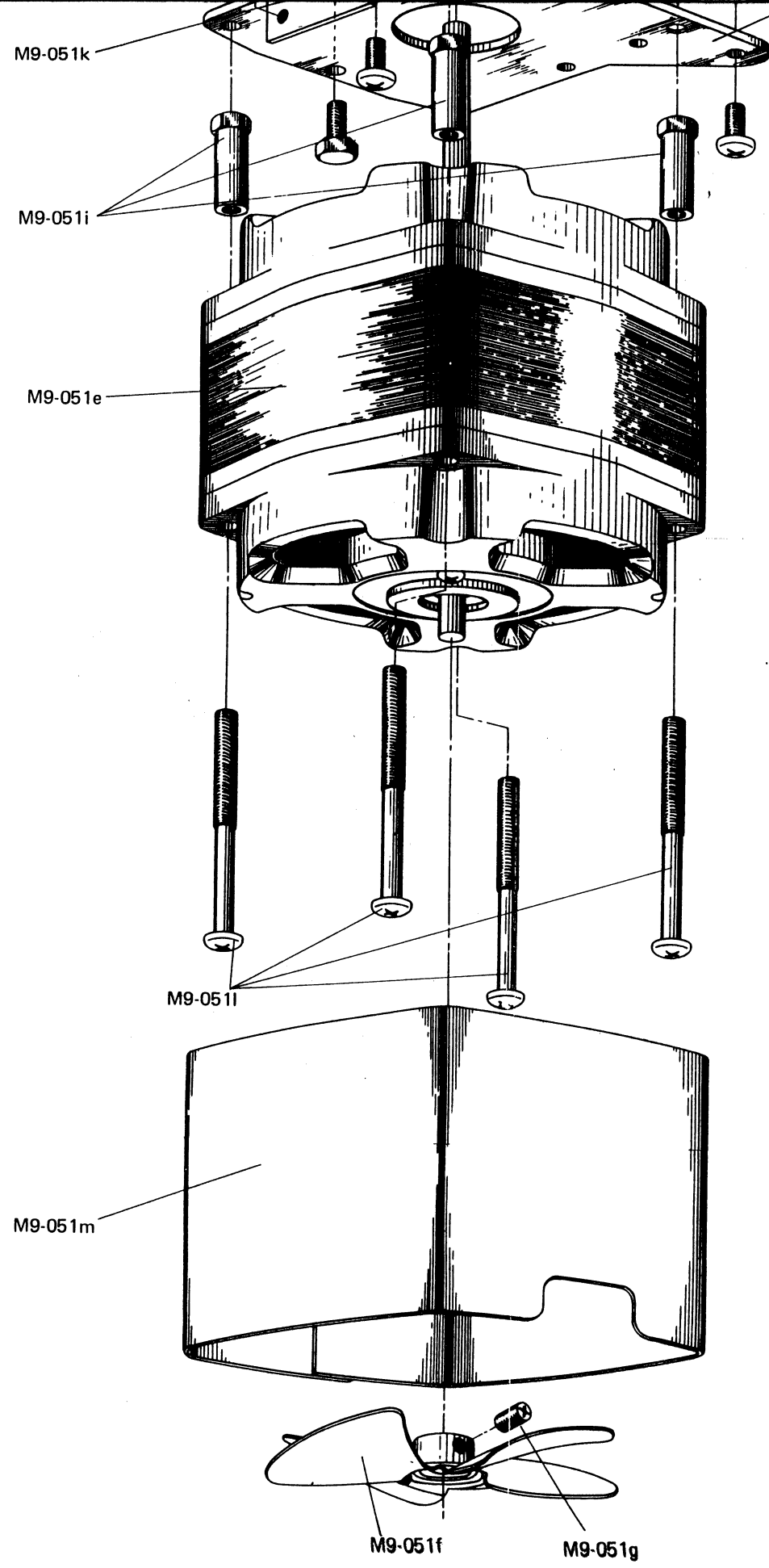

M - 9

N. Daterale.