

# SERVICE MANUAL

---

**AKAI TAPE DECK**

---

**MODEL**

**X-150D**

# TABLE OF CONTENTS

I	SPECIFICATIONS .....	1
II	MEASURING METHOD .....	2
III	LOCATION OF CONTROLS .....	4
IV	DISASSEMBLY OF TAPE TRANSPORT UNITS & AMPLIFIERS .....	5
V	TRANSPORT MECHANISM .....	7
VI	MECHANISM ADJUSTMENT .....	10
VII	AMPLIFIER ADJUSTMENT .....	12
VIII	MAINTENANCE PROCEDURES .....	14
IX	REPLACEMENT PARTS TABLE .....	15
X	EXPLODED VIEW OF COMPONENT PARTS .....	18
XI	TROUBLE SHOOTING CHART .....	25
XII	SCHEMATIC DIAGRAM .....	29
XIII	CONNECTING DIAGRAM .....	30

## I. SPECIFICATIONS

STYLE	: Portable	MIC. INPUT	: 0.5 mV~20 mV
WEIGHT	: 30.8 lbs (14.0 kg)	DIN. INPUT	: 20 mV~25 mV
DIMENSIONS	: 13-1/2" (H) × 13-1/2" (W) × 9" (D) (340 H × 340 W × 230 D mm)	MONITOR	
POWER		SYSTEM:	Can be monitored the program being recorded by using. Stereo headphone (8 Ohms) ... Stereo headphone jack Crystal receiver ..... Line output jack.
SUPPLY:	100, 110, 120, 200, 220, 240 V.A.C.	MOTOR	: Hysteresis synchronous 2-speed motor. Horse power : 1/100 HP Power ratio : 85% Revolution : 3,000 to 1,500 R.P.M. at 50 cps (Hz) 3,600 to 1,800 R.P.M. at 60 cps (Hz) Condenser capacity : 2.8 $\mu$ F at 50 cps (Hz) 2.0 $\mu$ F at 60 cps (Hz)
RECORDING		HEADS	
SYSTEM:	Inline 4-track stereo, monaural playback.	RECORDING/ PLAYBACK	
TAPE SPEED	: 3 speeds.....1-7/8, 3-3/4 and 7-1/2 ips (15 ips optional)	HEAD:	Inline 4-track stereo/monaural Gap ..... 0.2 microns Impedance ... 1,000 Ohms at 1,000 cps (Hz)
TAPE SPEED		BIAS HEAD	: Inline 4-track stereo Gap ..... 0.2 mm Impedance ..... 500 Ohms at 60 Kc
DEVIATION:	Less than $\pm$ 1.5% at all tape speeds.	ERASE HEAD:	Inline 4-track stereo. Gap ..... 0.2 mm Impedance ..... 300 Ohms at 60 Kc
WOW AND		RECORD LEVEL	
FLUTTER:	Less than 0.15% R.M.S. at 7-1/2 ips.	INDICATOR:	Vertical indication Model "A" VU meter $\times$ 2
(PLAYBACK	Less than 0.25% R.M.S. at 3-3/4 ips.	TRANSISTOR	
ONLY)	Less than 0.35% R.M.S. at 1-7/8 ips.	USED:	2SC650 (A) $\times$ 4 2SC281 (B) $\times$ 4 2SC458 (B) $\times$ 2 2SC696 (J) (I) (F)
FREQUENCY		SILICON	
RESPONSE:	30 to 23,000 cps (Hz) at 7-1/2 ips. 30 to 18,000 cps (Hz) at 3-3/4 ips. 30 to 9,000 cps (Hz) at 1-7/8 ips.	DIODE USED:	SW-05-01 $\times$ 5
SIGNAL TO		REELS USED	: 7", 5", 3" reels
NOISE RATIO:	Better than 50 db.		
DISTORTION	: Within 2% at 1,000 cps (Hz) recording. (TOTAL HARMONICS)		
CROSS-TALK	: Less than -65 db (Monaural) Less than -43 db (Stereo)		
INSULATION			
RESISTANCE:	More than 50 M.Ohms.		
INSULATION			
DURABILITY:	1,000 V.A.C. for more than one minute duration.		
ERASE RATIO	: Less than -70 db for all tracks.		
POWER CON-			
SUMPTION:	55 VA		
EQUALIZA-			
TION:	Correct equalization for playback of tapes recorded to the NAB curve.		
FAST FORWARD			
AND REWIND			
TIME:	90 seconds using 1,200 feet tape at 50 cps (Hz); 75 seconds at 60 cps (Hz).		
OUTPUT			
LEVEL:	1.228 V (0 VU) at using 1,000 cps (Hz) 0 VU recorded tape.		
OUTPUT			
IMPEDANCE:	1.5 K.Ohms		
OUTPUT LEVEL			
OF STEREO			
HEADPHONE:	30~40 mV		
OUTPUT			
IMPEDANCE OF			
STEREO			
HEADPHONE:	8 Ohms		
INPUT LEVEL			
LINE INPUT	: 50 mV~2.5 V		

## II. MEASURING METHOD

### TAPE SPEED DEVIATION

1. Method involving use of pre-recorded tape.

Playback on the tape recorder to be tested tape pre-recorded at 1,000 cps  $\pm 0.1\%$  for measuring tape speed deviation. Connect the appropriate output to a frequency counter meter in order to measure the tape speed deviation from the resulting deviation of the measured frequency.

2. Method involving use of timing tape (designed for tape speed measurement).

This method utilizes a timing tape marked at intervals of  $7\frac{1}{2}''$ . The running time of the tape over 60 marked section is measured in order to calculate the deviation of the tape speed. In application of this method, however, it should be borne in mind that should the timing tape stretch or contract, measurement error is inevitable, so that it is necessary to measure the total length of the tape in advance.

### WOW AND FLUTTER

Playback the 3,000 cps pre-recorded tape whose wow and flutter level is guaranteed to be smaller than  $0.07\%$  for measurement by means of a wow meter. It is also possible for a 3,000 cps sine wave to be recorded and played for measurement by means of the wow meter. In this case, however, the wow meter indicates a value as much as twice the value given in the specification on the first page.

### SIGNAL TO NOISE RATIO

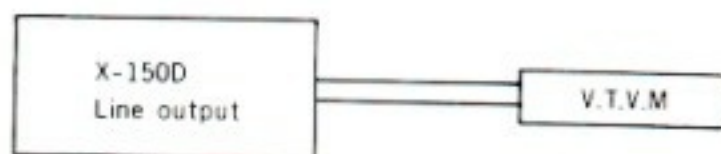

Set the Equalizer Switch on " $7\frac{1}{2}$  ips" position and playback a tape containing a 1,000 cps sine wave recorded at "0" VU level on a standard recorder. Connect a V.T.V.M. to the line output jack of the recorder and measure its output.

Then remove the tape and measure the noise level under the same condition. Convert into decibels each of the measured values.

### TOTAL HARMONIC DISTORTION FACTOR

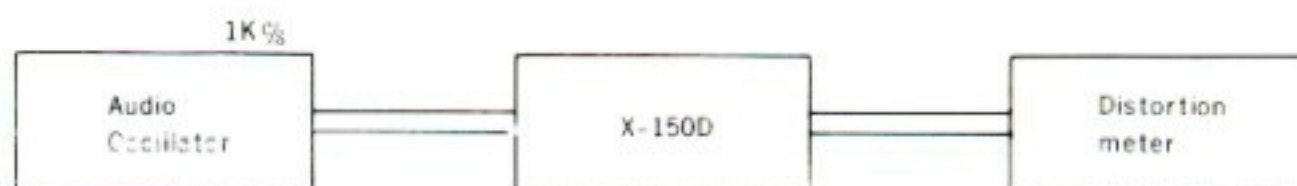

Connect the measuring instrument as shown above, and record the 1,000 cps sine wave at "0" VU. Playback the resultant signal and measure the overall distortion factor. Measure the noise level of the tape recorder with the tape removed: connect the audio oscillator directly to the distortion meter for measurement of the distortion factor of the oscillator.

The required distortion factor may be obtained from the results of the above measurement by the following formula.

$$d_0 = d - d_1 - d_2$$

where,  $d_0$  = Required

$d$  = Overall distortion factor

$d_1$  = Noise level

$d_2$  = Distortion factor of the oscillator

(Note: New tape of particularly good quality should be used for measurement of the distortion factor).

### POWER OUTPUT

Playback a tape containing a sine wave of 1,000 cps recorded at 0 VU on a standard recorder.

Connect a V.T.V.M. to the line output jack of the recorder and measure the voltage at the output of the recorder to be tested.

**CROSS TALK (Cross talk between the tracks)**

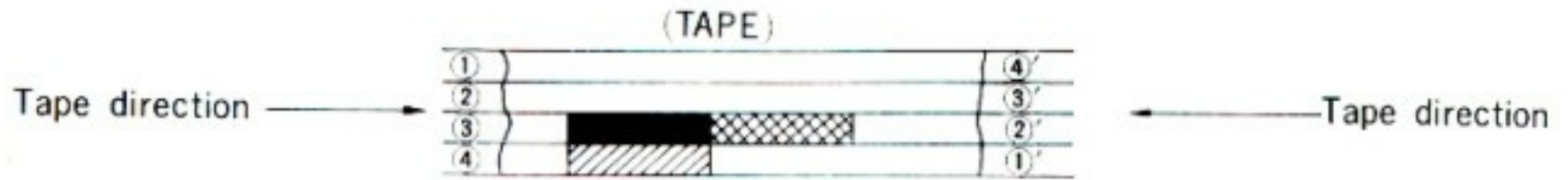

As shown in the figure, first record a 1,000 cps sine wave on track No. 3 at +3 VU level. Next, remove the 1,000 cps input signal and record under a non-input condition.

Then, playback the tape on track No. 3 and No. 1 (reversed condition of tape) through the 1,000 cps B.P.F. (Band Pass Filter, Sensitivity...1:1) and obtain a ratio between the two from the following formula.

$$C = 20 \log \frac{E_0}{E_2 - E_1} \text{ (db)}$$

{

$C$  = Desired cross talk ratio (db)

$E_0$  = 1,000 cps signal output level

$E_2$  = 1,000 cps cross talk output level

$E_1$  = No-input signal record level

**FREQUENCY RESPONSE**

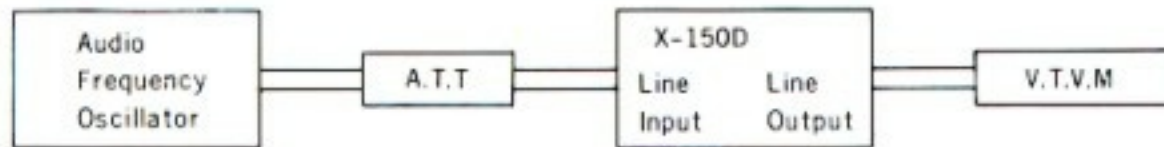

Connect the measuring instrument as in the above diagram, and measure the frequency response in the following sequence :

**RECORD :**

- 1) Give a sine wave of 1,000 cps to the Line Input of the recorder to be tested through an attenuator from an audio frequency generator.
- 2) Set the Record/Playback Knob in to "Rec" position and adjust the line input volume so that the VU meter needle indicates "0" VU.
- 3) Under the condition described in (2), lower the input level 10 db by means of the attenuator.
- 4) Record the spot frequency in the range of 30 cps to 25,000 cps from the audio frequency generator.

**PLAYBACK :**

- 5) Set the Record/Playback Knob in to "Play" position.
- 6) Set the Equalizer Switch on 7-1/2" or 3-3/4" position.
- 7) Connect a V.T.V.M. to the Line output.
- 8) Playback the tape previously recorded.
- 9) Adjust the output level to "0" dbm at 1,000 cps as indicated on the V.T.V.M. by the range selector of a V.T.V.M.
- 10) Playback the recorded spot frequencies with the conditions in (9); make a memo of output level and plot the value on a graph.

### III. LOCATION OF CONTROLS

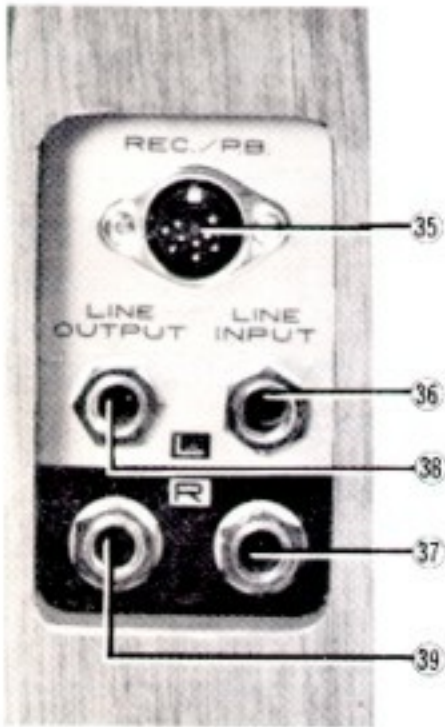
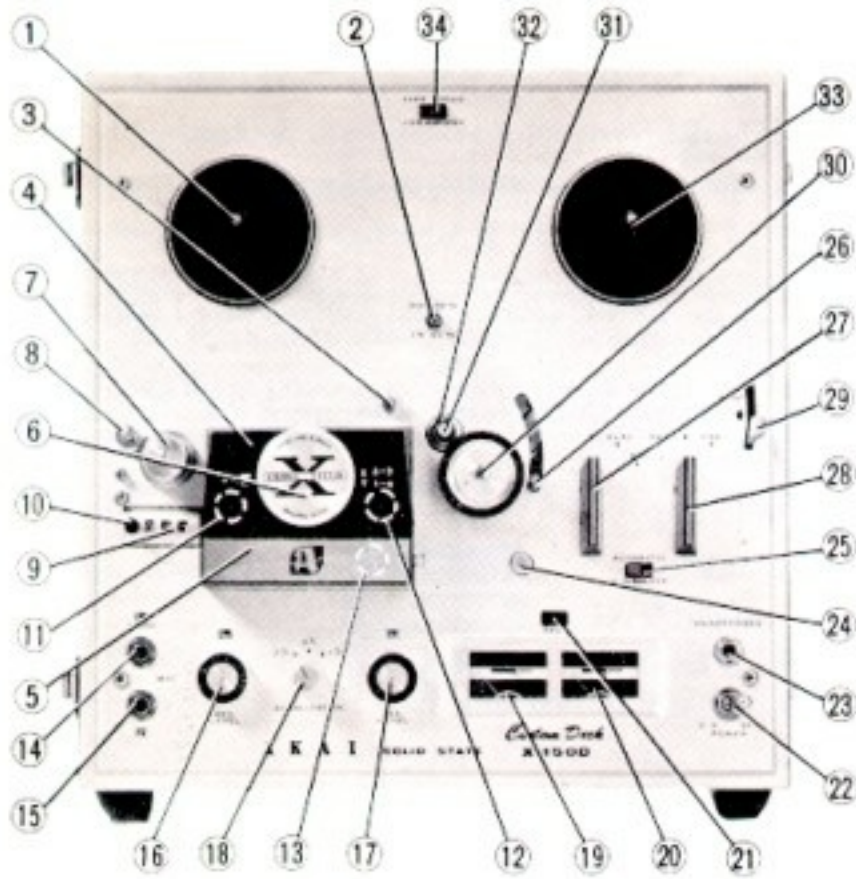

- |  |                               |
|--|-------------------------------|
| ① Supply Reel Shaft                    | ⑳ Power Switch                |
| ② Cycle Conversion Switch (A)          | ㉑ Stereo Headphone Jack       |
| ③ Capstan Storage Post                 | ㉒ Recording Safety Button     |
| ④ Head Cover (A)                       | ㉓ AS Switch                   |
| ⑤ Head Cover (B)                       | ㉔ AS Lever                    |
| ⑥ Track Selector Knob                  | ㉕ Record/Playback Knob        |
| ⑦ Tape Guide                           | ㉖ Fast-Forward/Rewind Knob    |
| ⑧ Tape Cleaner                         | ㉗ Instant Stop Lever          |
| ⑨ Index Counter                        | ㉘ Pinch Wheel                 |
| ⑩ Reset Button                         | ㉙ Capstan Shaft               |
| ⑪ Erase Head                           | ㉚ Capstan                     |
| ⑫ Recording/Playback Head              | ㉛ Take-Up Reel Shaft          |
| ⑬ Bias Head                            | ㉜ Speed Change Switch         |
| ⑭ Microphone Jack (Left)               | ㉝ DIN Jack                    |
| ⑮ Microphone Jack (Right)              | ㉞ Line Input Jack (Left)      |
| ⑯ Recording Level Control Knob (Left)  | ㉟ Line Input Jack (Right)     |
| ⑰ Recording Level Control Knob (Right) | ㊱ Line Output Jack (Left)     |
| ⑱ Equalizer Knob                       | ㊲ Line Output Jack (Right)    |
| ㉑ VU Meter (Left)                      | ㊳ Voltage Conversion Switch   |
| ㉒ VU Meter (Right)                     | ㊴ Fuse Post                   |
| ㉓ Recording Lamp                       | ㊵ Cycle Conversion Switch (B) |
|  | ㊶ AC Cord                     |

## IV. DISASSEMBLY OF TAPE TRANSPORT UNIT & AMPLIFIERS

- (1) Loosen the RETAINING SCREW (a) of PINCH WHEEL (b) using a phillips-headed screw driver and remove the PINCH WHEEL by hand.

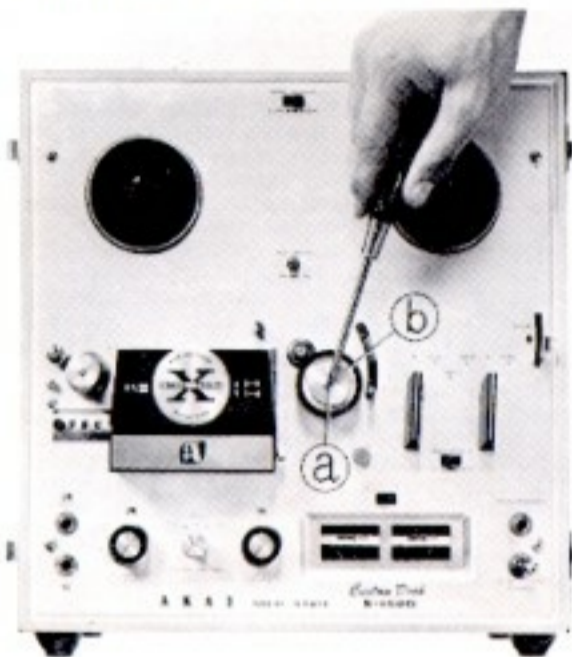

- (2) Loosen the RETAINING SCREW (a) of the TRACK SELECTOR KNOB (b) using a phillips-headed screw driver and remove the TRACK SELECTOR KNOB by hand.

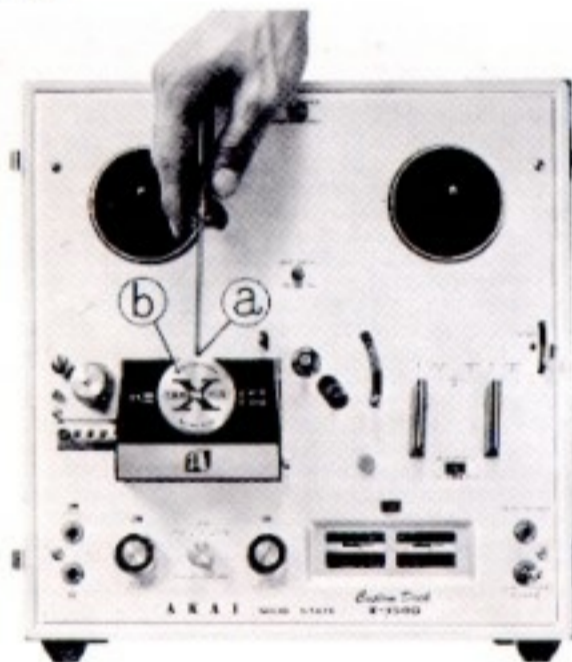

- (3) Loosen the RETAINING SCREWS of the KNOBS (a, b and c) by using a minus-headed screw driver and remove the KNOBS by hand.

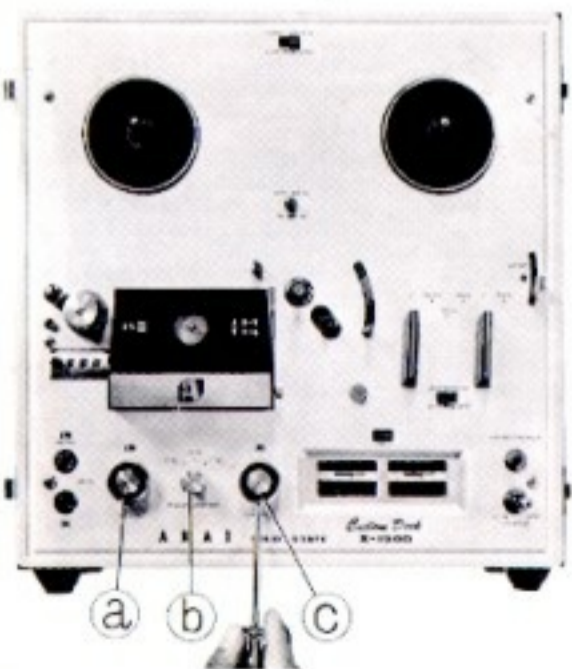

- (4) Loosen the RETAINING SCREWS of the DECK CONTROL KNOBS (a and b) by using a phillips-headed screw driver and remove the KNOBS by hand.

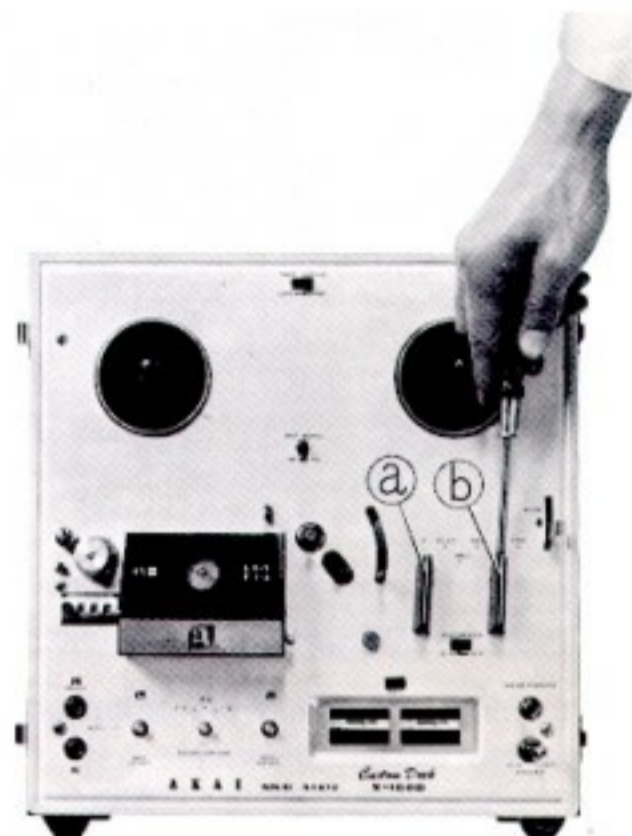

- (5) Loosen the SCREWS (marked from a to d) by using a phillips-headed screw driver and remove the DECK PANEL by hand.

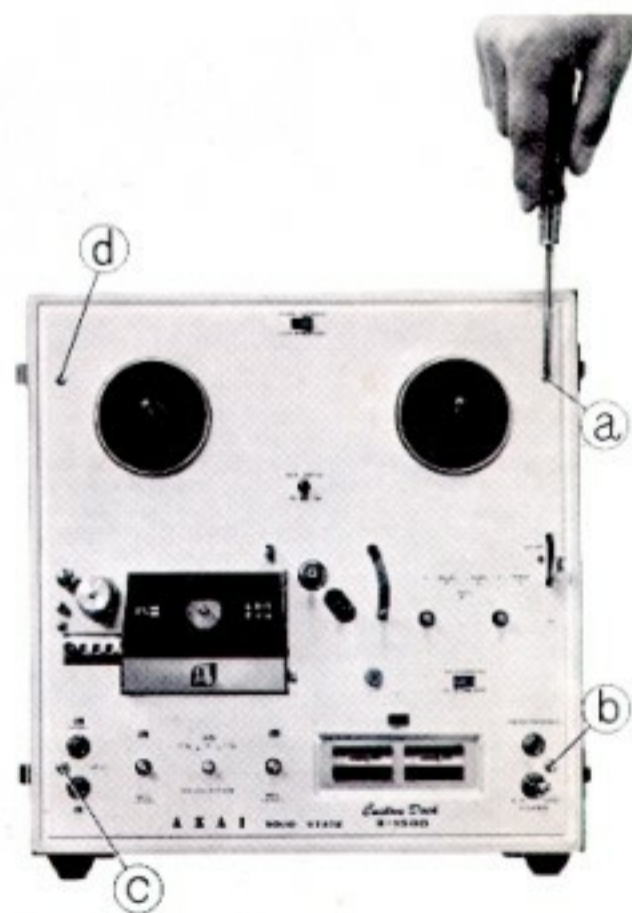

(6) Loosen the SCREWS (marked from ① to ④) by using a phillips-headed screw driver.

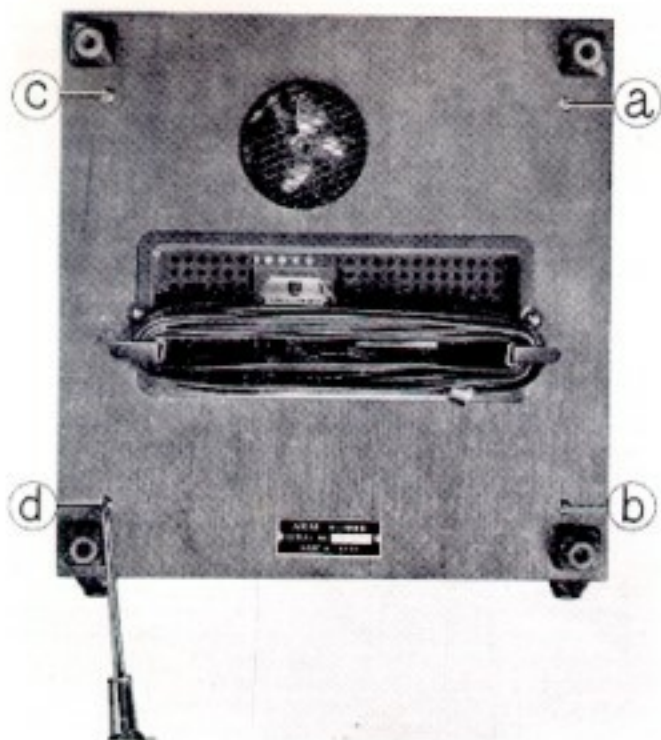

(7) Loosen the SCREWS (marked from ① to ④) by using a phillips-headed screw driver.



(8) Remove the TAPE TRANSPORT MECHANISM ASSEMBLY and AMPLIFIER ASSEMBLY ① by slowly lifting it from the CASE ② as shown in picture.

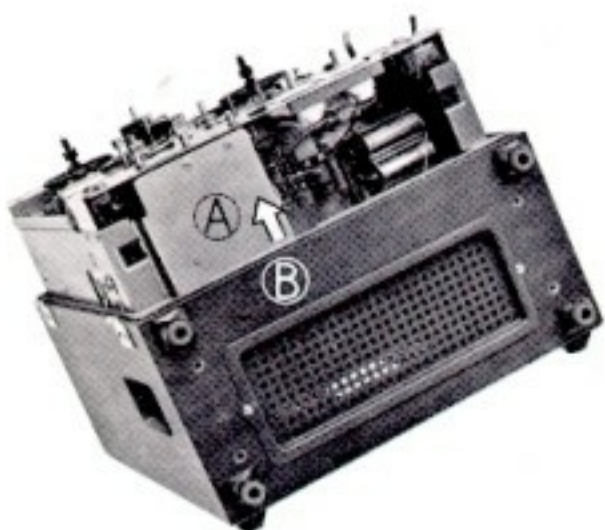

(9) Disconnect the PLUGS (marked ① to ④) carefully by hand.

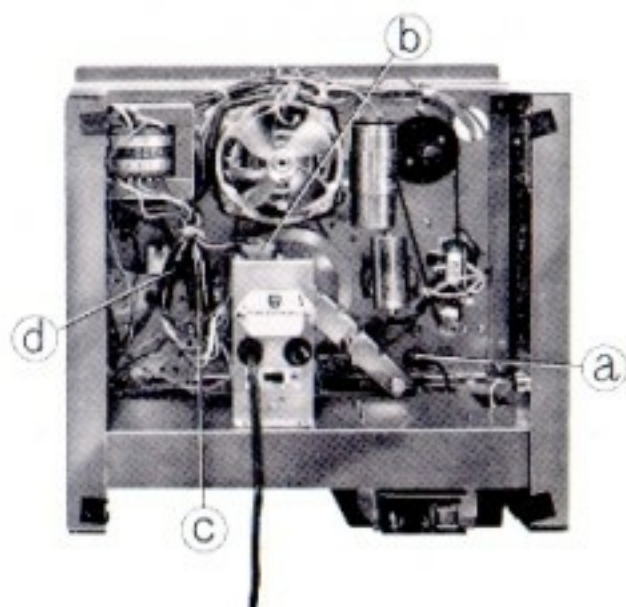

(10) Loosen the SCREWS (marked from ① to ④) of the DECK FRAME by using a phillips-headed screw driver.



(11) Separate the TAPE TRANSPORT MECHANISM ASSEMBLY ① from AMPLIFIER ASSEMBLY ② carefully by hand.





## V. TRANSPORT MECHANISM

### Driving of Capstan

Figure 1.

- Ⓐ Motor
- Ⓑ Driving Belt (flat belt)
- Ⓒ Capstan
- Ⓓ Flywheel

High-speed rotation of *Motor* Ⓐ is reduced by *Driving Belt* Ⓑ and transmitted to *Capstan* Ⓒ, which is connected of flywheel with ample inertia and enables rated rotation by absorbing minor rotation distortion of motor itself.

Capstan Rotation :

606 R.P.M. at 7-1/2" (19 cm) per sec.

303 R.P.M. at 3-3/4" (9.5 cm) per sec.

151.5 R.P.M. at 1-7/8" (4.75 cm) per sec.

Motor Rotation :

3,000 to 1,500 R.P.M. at 50 cps.

3,600 to 1,800 R.P.M. at 60 cps.

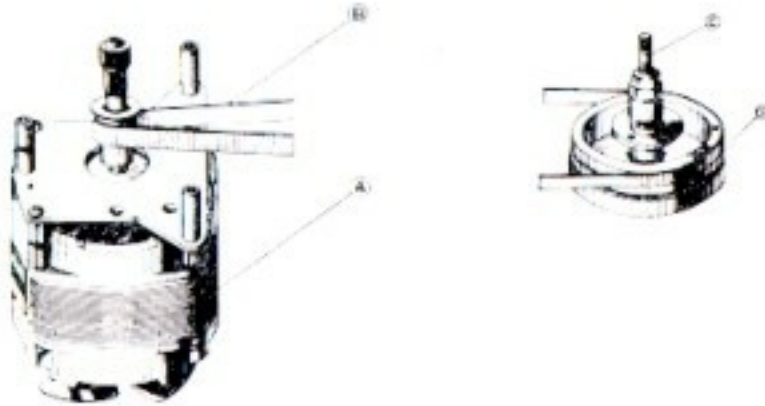

Fig. 1

### Driving of Pinch Wheel

Put tape between rotating capstan and pinch wheel and push pinch wheel against capstan, this will transport the tape at rated speed. The appropriate pressure of pinch wheel is between 1,000 to 1,150 grams at the tape speed of 7-1/2" (19 cm) per second.

### Recording and Playback

Turn the *RECORD/PLAYBACK KNOB* Ⓐ to "PLAY" position, and pinch wheel presses against capstan to move tape at the rated speed. At the same time, *Idler* Ⓑ moves between *Motor Bushing* Ⓒ and the *Take-Up Reel Spindle* Ⓓ to transmit the motor rotation to Ⓓ so that the tape is moved and wound on the take-up reel.

The Take-up Reel Spindle Base is made up of two plastic rollers (1 and 2) with a clutch felt in between. The Idler is rotating the plastic roller ② under. Therefore, the tape-winding friction is adjusted by the slipping of the felt to enable rated winding of the tape.

On the other hand, the *Supply Reel Spindle* Ⓔ has a *Brake Roller* Ⓕ hung on the Plastic Roller ④ under which provides appropriate back tension by the clutch felt slipping to the rotation of the Pulley ③ above.

To prevent accidental erasure, the *Record Interlock Button* Ⓖ must be depressed before the *RECORD/PLAYBACK KNOB* can be moved to the "REC" position. The *Safety device* Ⓖ is depressed to enter the record mode.

(See figure 2)

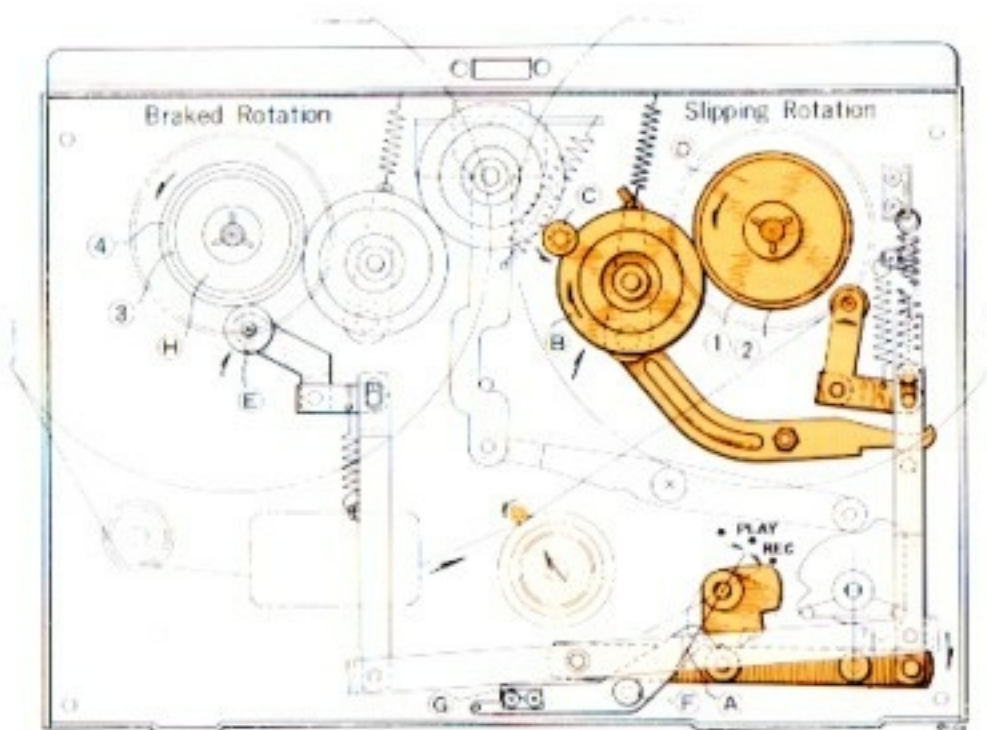
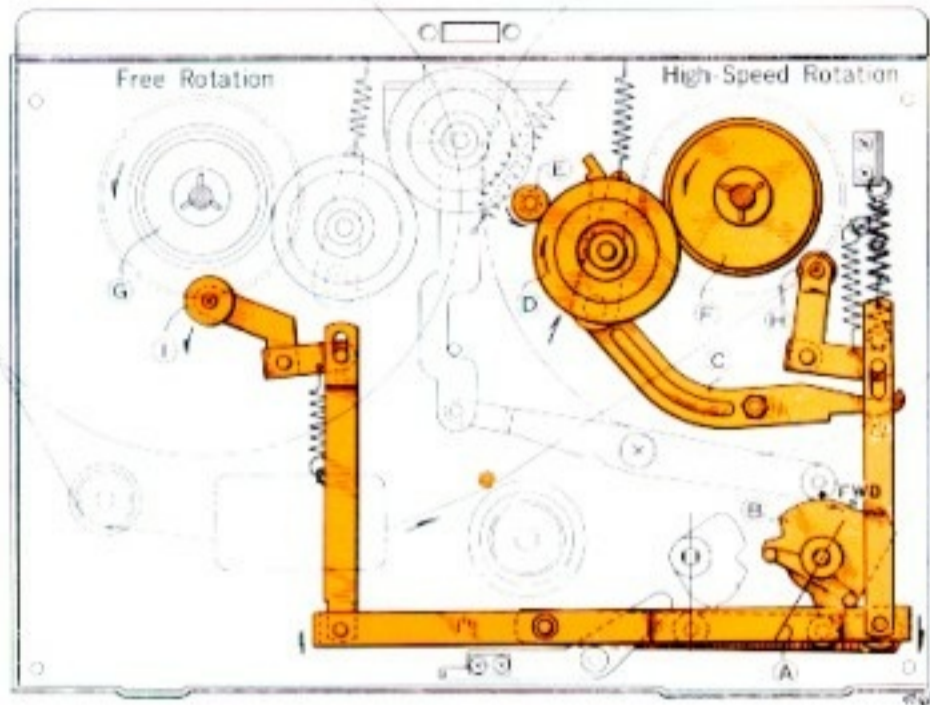

Fig. 2



### FAST-FORWARD MECHANISM

Turn the *FAST FWD-REWIND knob* (A) to "FAST FWD" position, and the cam (B) under the knob pushes up the *Lever* (C). The *Idler* (I) moves into the space between the *Plastic Roller* (F) above the *Take-Up Reel Spindle* and the upper part of the rotating motor drive bushing to transmit the motor rotation to the take-up reel spindle. At the same time, *Brake Rollers* (J) and (K) come off the reel spindle to free the *Supply Reel Spindle* (G), thereby allowing fast winding of the tape onto the take-up reel.

(See figure 3)

Fig. 3

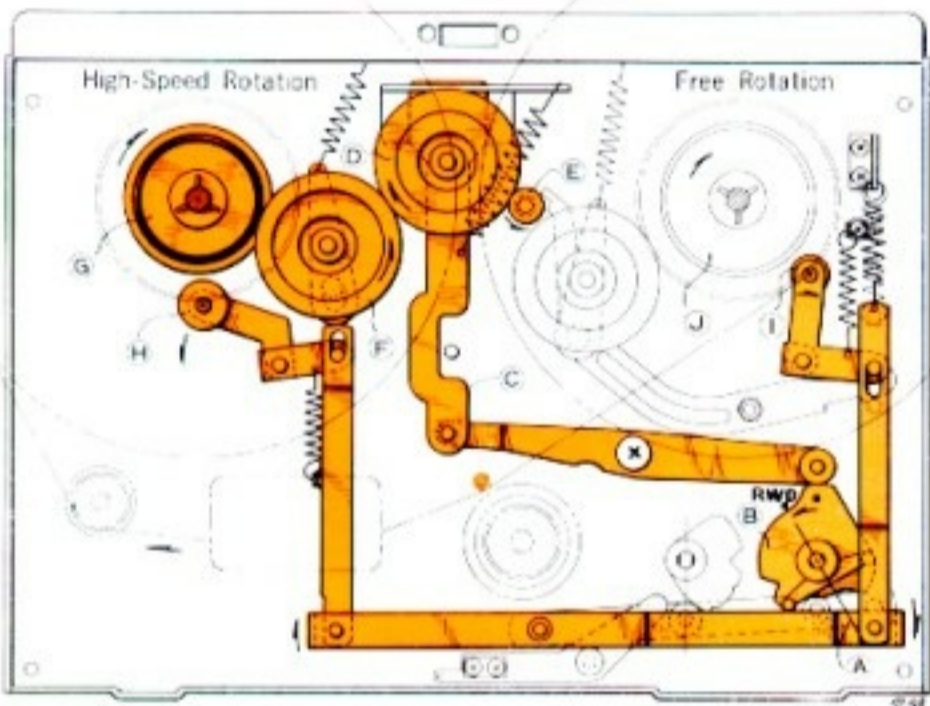

### REWIND MECHANISM

Turn the *FAST FWD-REWIND knob* (A) to "REWIND" position, and the cam (B) under the knob pushes the *Lever* (C) up. The *Idler* (I) moves into the space between the upper part of the rotating *Motor drive bushing* (E) and the *Intermediate Pulley* (F) to transmit the high-speed rotation of the motor through the intermediate pulley to the *Supply Reel Spindle* (G). At the same time, *Brake Rollers* (J) and (K) come off the reel spindle to free the *take-up reel spindle* (D), thereby rewinding the tape into the supply reel at a fast speed.

(See figure 4)

Fig. 4

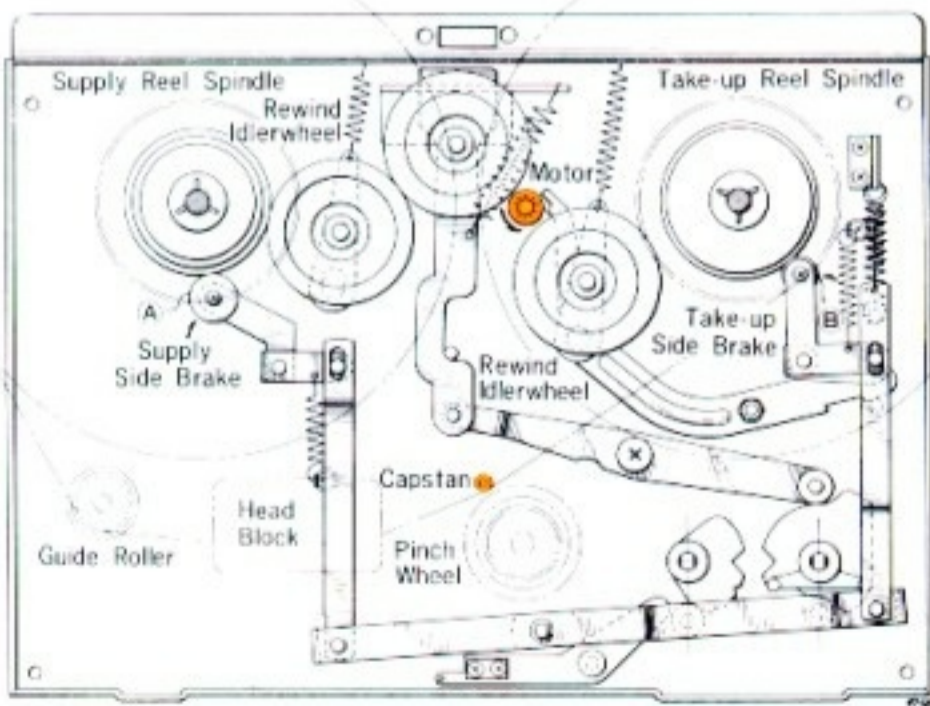

### STOP CONTROL

Push the stop lever to "STOP" position, *Brake Rollers* (A) and (B) depress reel spindles to stop rotation of the reel spindles.

As the brake rubber depresses the plastic rollers under the reel spindles, no friction works on the tape itself.

Fig. 5

Modes of Operation	Pinch Wheel	Take-up Idler Wheel	Rewind Idler Wheel	Take-up side Brake	Supply side Brake
(a) STOP	×	×	×	○	○
(b) FAST-FORWARD	×	○	×	×	×
(c) REWIND	×	×	○	×	○
(d) RECORDING PLAYBACK	○	○	×	×	×

NOTES: ×-marks indicates "open" and  
○-marks "engaged"

### RECORD/PLAYBACK CHANGING MECHANISM

By turning the RECORD/PLAYBACK KNOB ⑧ to the recording position, the LEVER ⑩ pushes the RECORDING LEVER ⑥ and ⑦, as illustrated in dotted line, then the RECORD/PLAYBACK CHANGING SWITCH (SWI) turns to recording position.

If the LEVER ⑥ does not push the LEVER ⑦ properly, the SWI does not operate properly so may occur the abnormal oscillation and also can't record.

Then must adjust the LEVER ⑥ to proper position by loosening the SCREW ④.

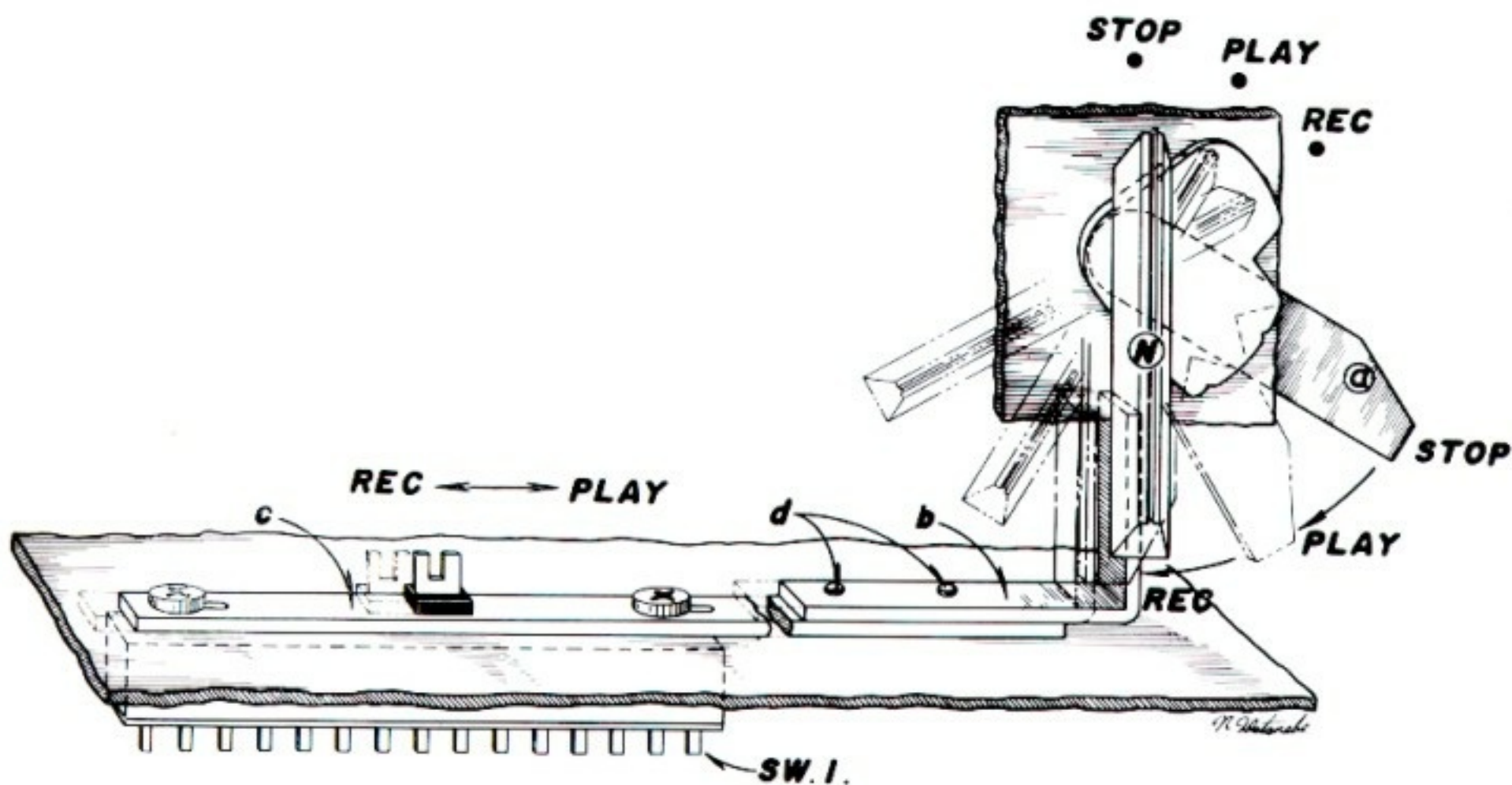

Fig. 6

## VI. MECHANISM ADJUSTMENT

### 1. ADJUSTMENT OF PINCH WHEEL

It is important that the pinch wheel shaft is kept in complete alignment with the capstan shaft. A proper pinch wheel pressure is between 1,000 and 1,150 grams when the unit is operated at the tape speed of 7-1/2 ips. Any deviation from this specification will result in wow and flutter. Check pinch wheel pressure by a spring scale, and if necessary, adjust the pinch wheel load spring.

### 2. ADJUSTMENT OF TAKE-UP IDLER WHEEL

The take-up idler wheel must be kept in complete alignment with the take-up reel shaft. When the unit is set in fast forward condition, the idler wheel will contact to the upper knurled wheel of the take-up reel shaft assembly, and it will contact to the lower knurled wheel during record or play mode. Adjust idler wheel load spring so that the idler wheel pressure is kept between 50 and 80 grams. The idler wheel rapidly wears if the pressure is excessive. The slippage occurs if the pressure is smaller than the specification.

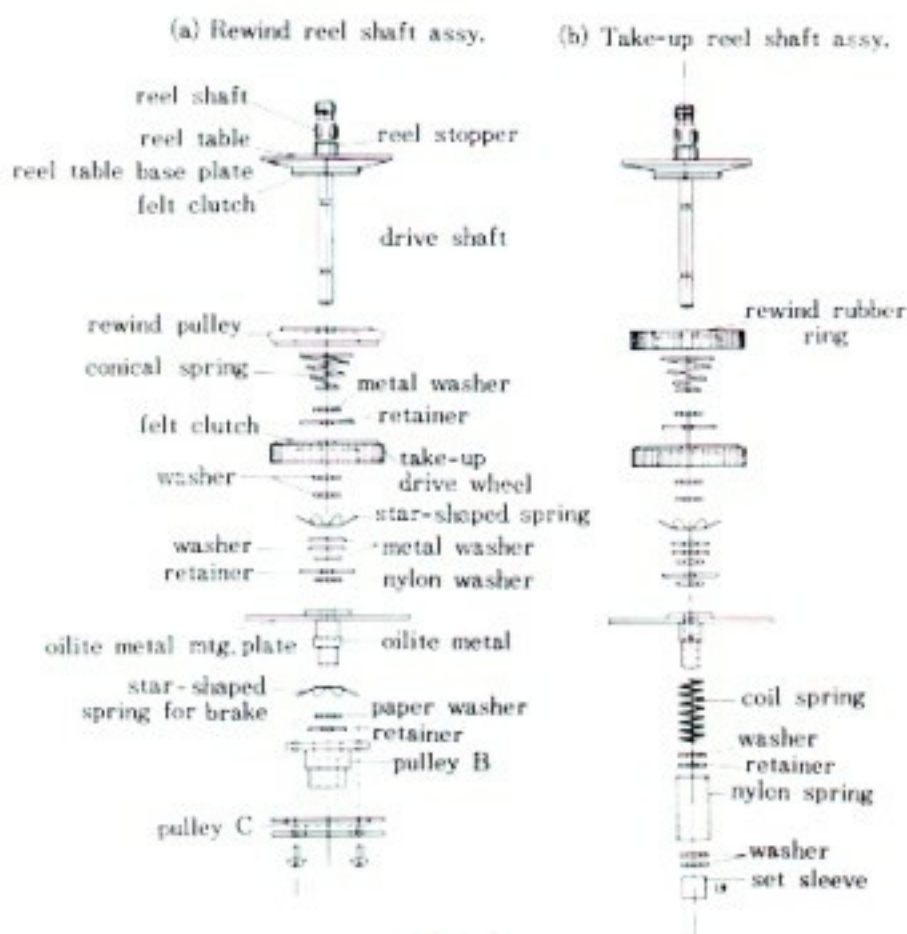

Fig. 1

### 3. ADJUSTMENT OF REWIND IDLER WHEEL

The rewind idler wheel must be kept in complete alignment with the rewind reel shaft. The amount of pressure to the knurled motor bushing should be maintained about 50 grams during rewind operation. Adjust both the idler load spring and rewind roller.

### 4. ADJUSTMENT OF INTERMEDIATE WHEEL

The intermediate wheel is located between the rewind idler wheel and the rubber ring which is used on the upper part of the supply reel shaft assembly. When the unit is set in rewind mode, it will contact to these parts simultaneously delivering torque of motor. An adequate pressure is 50 grams. Adjust the load spring of the intermediate wheel if the pressure is not sufficient.

### 5. ADJUSTMENT OF TAKE-UP REEL SHAFT ASSEMBLY

A felt clutch material is attached to the bottom side of the reel table base plate so that recording tape will not be stretched during fast forwarding operation due to excessive tension. To check the amount of friction of this part, place a 5-inch reel with recording tape wound by 60 m/m in diameter, and gently pull the end of tape upward using a spring scale. Adjust the conical spring so that the amount of tension at this part will be kept between 400 to 500 grams. Another felt clutch material is attached to the take-up drive wheel. It is to provide proper slipping operation during record or play mode. The procedure for checking friction of this part is same as the foregoing, and between 150 and 200 grams of friction will provide the best result. Adjust the star-shaped spring just under the take-up drive wheel. When the unit is set in rewind mode, the amount of friction of this part will greatly be reduced and will become 15 to 20 grams. Check to see whether this is satisfactory if not, readjust the star-shaped spring for Brake, and spring retainer washed accordingly. (See figure 1 (b) at left)

### 6. ADJUSTMENT OF SUPPLY REEL SHAFT ASSEMBLY

A felt clutch material is used between the lower side of the reel table base plate and the rewind rubber ring to protect recording tape from an excessive tension while rewinding operation. To check the amount of friction of this part, place onto the supply reel table a 5-inch reel with recording tape wound by 60 m/m in diameter and gently pull the end of tape upward by a spring scale. Adjust the conical spring so that the amount of tension is kept between 400 and 500 grams. Another felt clutch is attached to the rewind drive wheel to provide proper slipping operation during record or play mode. The procedure for checking friction of this part is same as the foregoing, and between 80 and 120 grams of friction will give the best result. When the unit is set in fast forward mode, the amount of friction will greatly be reduced and will become 15 to 20 grams.

Check to see whether this is proper, if not, readjust coil spring and spring retainer washer. (See figure 1 (a) at left)

## 7. ADJUSTMENT OF HEAD

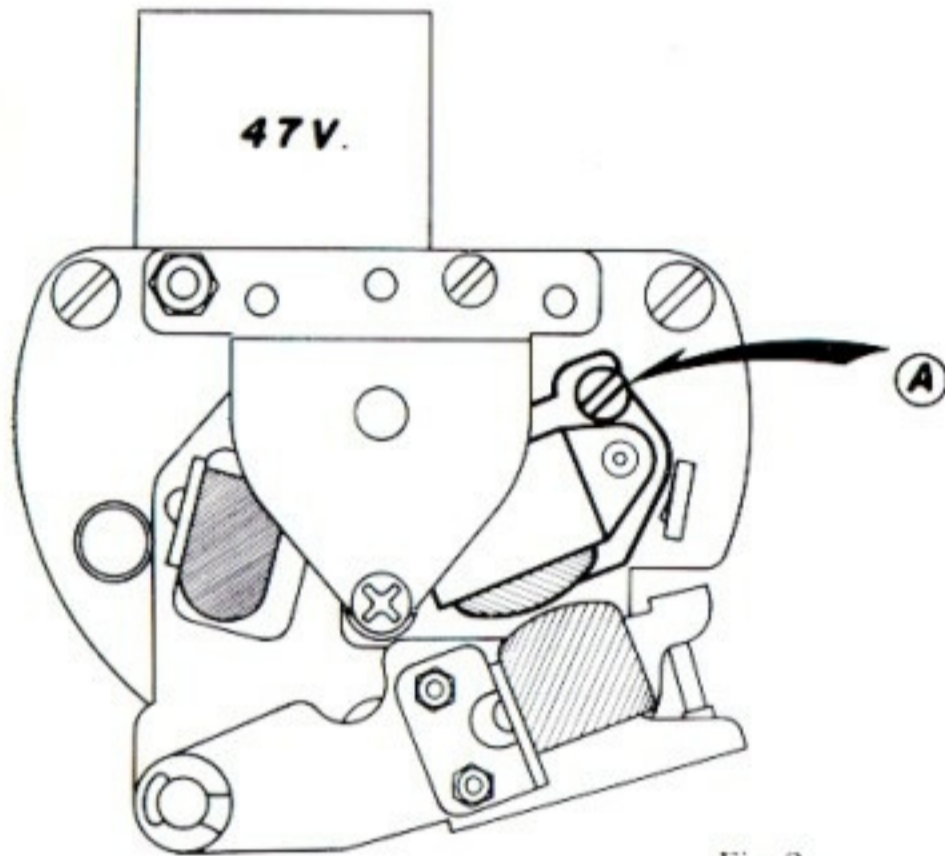

Fig. 2

- a) Playback 8,000 cps recorded tape and set the azimuth alignment of the Recording/Playback Head by turning the screw **A** until the voltage of the Line Output or the VU meter reads at a maximum.
- b) Adjustment of Head Level.

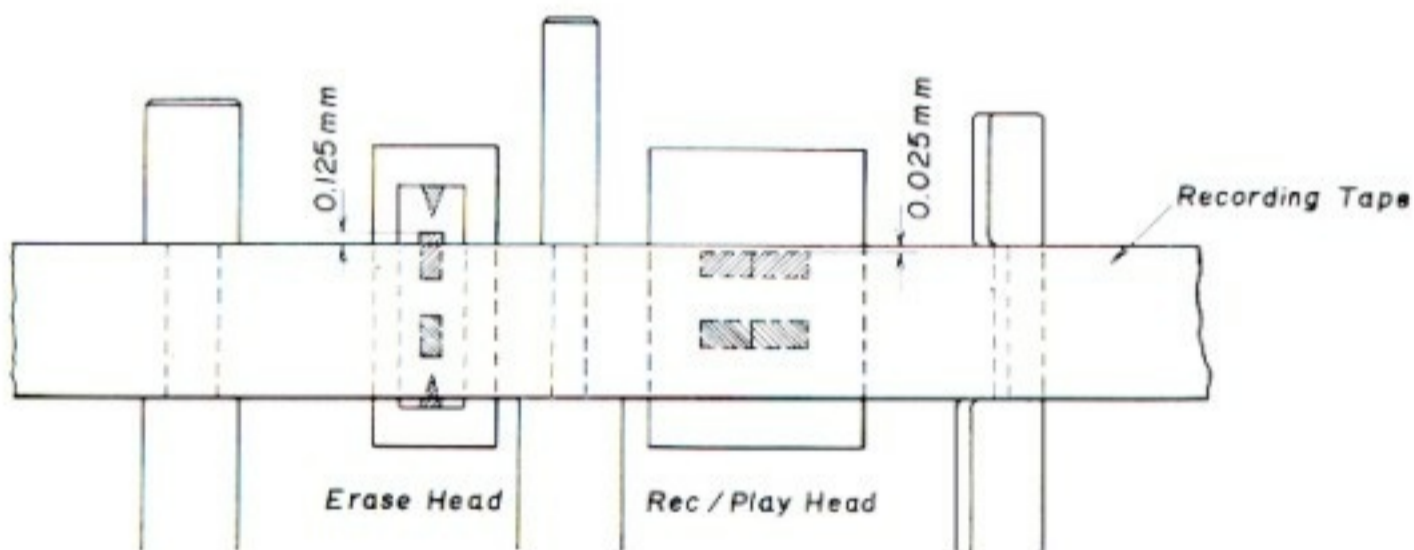
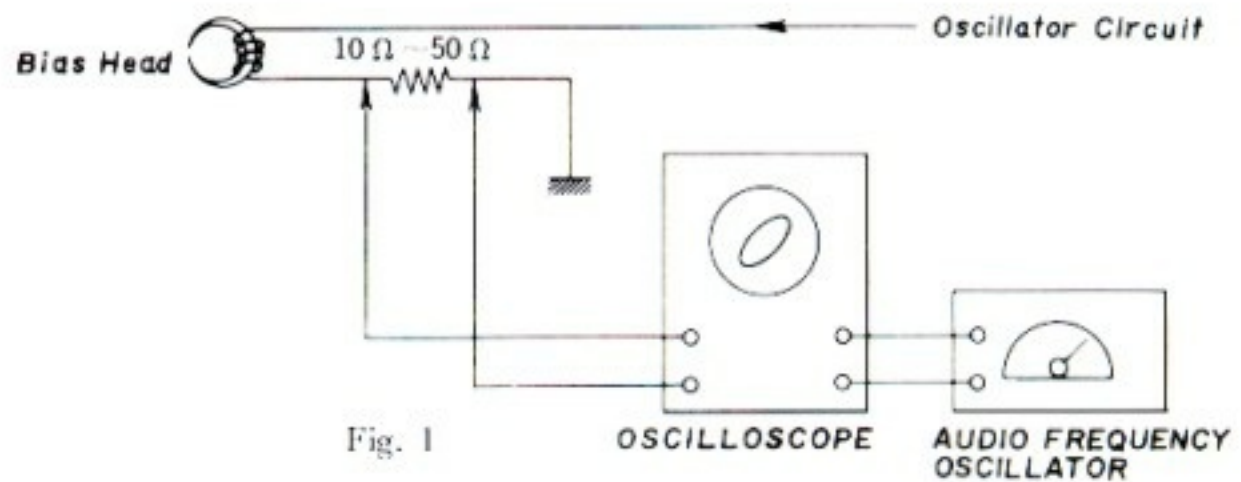

Fig. 3

- ① Position the Erase Head about 0.125 mm above the upper edge of the tape by adjusting the height of the cam provided in the lower part of the head assembly.
- ② Adjust the position of the Recording/Playback Head in a manner illustrated in figure 3 by adjusting the level control nut **A** at the lower part of the head assembly.

## VII. AMPLIFIER ADJUSTMENT

### 1. ADJUSTMENT OF RECORDING BIAS FREQUENCY



- a) Connect the resistor ( $10\ \Omega$  or  $50\ \Omega$ ) in series with the bias head, and connect the signal from the resistor to the vertical input of the oscilloscope. The output of the audio frequency oscillator should be connected to the horizontal input of the oscilloscope. Proper Bias frequency of the recorder X-150D is obtained when the oscilloscope displays a circular or linear waveform with the frequency of the audio frequency oscillator in the neighbourhood of  $60\ \text{kc/s}$ . The frequency of the bias oscillator circuit can be adjusted by converting the value of the condenser (C 18.  $10,000\ \text{PF}$ ).

### 2. ADJUSTMENT OF RECORDING BIAS VOLTAGE

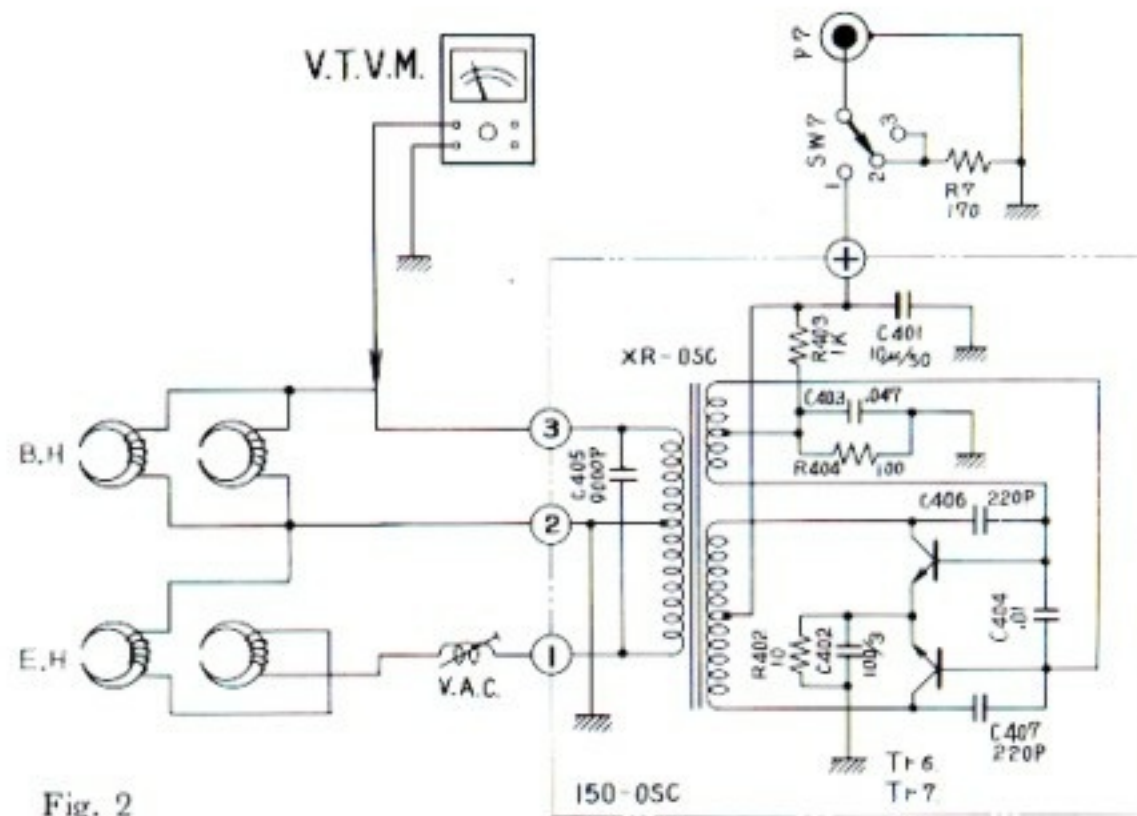

- a) Connect the V.T.V.M. to the bias head and fix the recording bias voltage by adjusting the V.A.C in the bias oscillator circuit (located near the head assembly) until its readings becomes equal to the bias voltage stamped backside the head assembly. Normal bias voltage is between  $60\ \text{V}$  and  $70\ \text{V}$ , while acceptable terminal voltage of the erase head is between  $12\ \text{V}$  and  $18\ \text{V}$ .

### 3. ADJUSTMENT OF PLAYBACK GAIN

- a) Playback 0 VU tape recorded with 1,000c/s signal information and adjust the semi-fixed resistor VR201 (20K $\Omega$ ) of the preamplifier card so that the pointer of the VU meter registers on 0 VU point (intermediate between red and black).
- b) When performing the above adjustments, make sure that the equalization switch has been set in coincidence with the speed of the tape.

### 4. ADJUSTMENT OF RECORDING LEVEL

- a) The recording level should be adjusted after the playback gain has been adjusted in the manner described.
- b) Set a standard tape (SCOTCH-111) on the recorder X-150D and put it in a recording mode of operation.
- c) Connect the signal of 1,000c/s from the audio oscillator to the line input of the recorder X-150D, and adjust the volume control so that the pointer of the VU meter registers on 0 VU (intermediate between red and black).
- d) Now record the tape and check on playback whether the pointer of the VU meter comes on the 0 VU point.
- e) If the pointer of the VU meter fails to register with 0 VU, repeat the recording and playback by adjusting the semi-fixed resistor VR 161 (2K $\Omega$ ) of the recording preamplifier until the 0 VU reading is obtained both on recording and playback.

## VIII. MAINTENANCE PROCEDURES

### 1. LUBRICATION INSTRUCTION

For maximum service life and optimum performance, lubricate the parts identified below after each 500 hours of operation. Use only light machine oil of good quality.

Motor	
Flywheel Assembly	
Rewind Idler Wheel and Wind Take-Up Idler	1 drop
Intermediate Idler	1 drop
Pinch Wheel	1 drop

Also apply a liberal film of light machine grease to each roller surface of all levers and cams.

**CAUTION :** DO NOT OVER-LUBRICATE, AND WIPE OFF EXCESS OIL BY A COTTON SWAB SOAKED IN ALCOHOL. OTHERWISE, THE OVER-FLOWED LUBRICANT MAY BE SCATTERED DURING OPERATION. THE RUBBER COMPONENT PARTS WILL BE DETERIORATED.

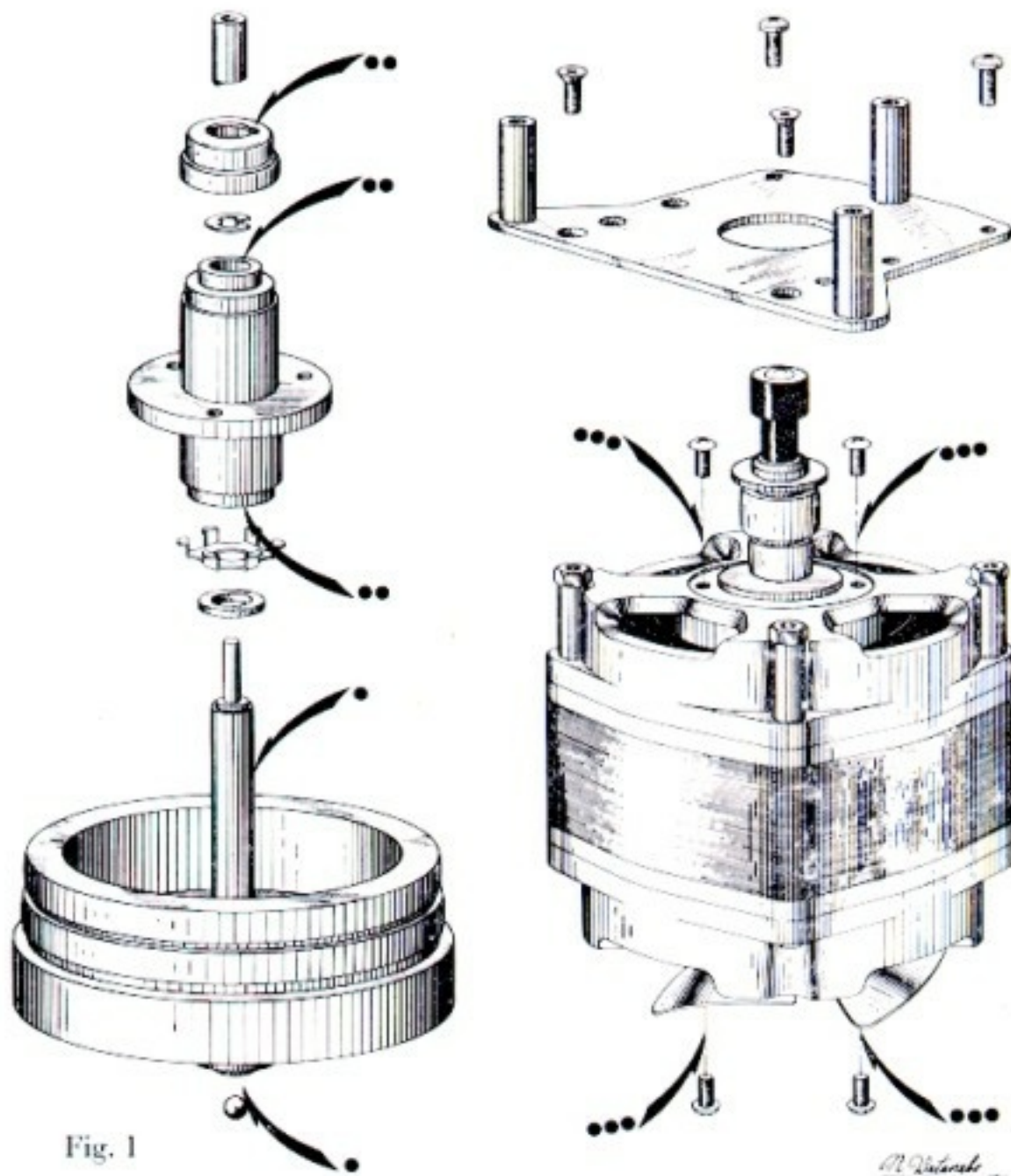

Fig. 1

FLYWHEEL.

● 1 drop

MOTOR

### 2. CLEANING TAPE HEADS AND OTHER PARTS

Wipe surface of tape heads, guide roller bearing, capstan bushing and pinch wheel periodically with a soft cloth soaked in alcohol or carbon-tet.



## IX. REPLACEMENT PARTS TABLE

Parts No.	Nomenclature	Parts No.	Nomenclature	Parts No.	Nomenclature
C1-001	* Deck Panel	C2-003	Tape Counter, Complete	C2-009d	Lever, Pinch Wheel
002	* Knob, Track Selector Control	003a	Pulley, Counter	009e	Shaft C, Pinch Wheel
002a	Screw, Retaining Track Selector Control Knob	003b	Belt, Counter	009f	Spring, Pinch Wheel
003	* Head Cover (Main)	004	* Supply Reel Assembly, Complete	009g	Shaft A, Cam Roller
004	* Head Cover (Sub)	004a	Retainer, Reel	009h	Cam Roller, B
005	Base, Head Cover	004b	* Reel Plate, Assembly	010a	Lever, Take-up Brake Roller
006a	Capstan Rest	004c	Rubber Ring	010b	Rubber (Small), Brake
006b	Capstan Holder	004d	Rewind Pulley	010c	Screw, Brake Roller
007a	Top Plate, Tape Guide	004e	Spring G (Left)	010d	Shaft, Brake Lever
007b	Table, Tape Guide	004f	Washer	011a	Lever, Supply Brake Roller
007c	Bearing, Tape Guide	004g	Thrust Washer Pin, Reel	011b	Rubber (Large), Brake
007d	Bottom Plate, Tape Guide	004h	Take-up Roller, C	011c	Screw, Brake Roller
008	Tape Cleaner, Complete	004i	Holder, Reel (Star Type Spring)	011d	Shaft, Brake Lever
008a	Felt, Tape Cleaner	004j	Nylon Washer	012a	6P Slide Switch ESS-22C-NB (Automatic Switch)
009	Prop A, Head Cover	004k	Washer	012b	Plate, Automatic Switch
010	Prop C, Head Cover	004l	Washer	013a	Speed Change Switch
011	Escutcheon, Recording Lamp	004m	Thrust Washer Pin, Reel	013b	Table, Speed Change Switch
<b>DECK FRAME</b>		004n	Washer	013c	* Spring, Lever FB
C2-001	* Deck Frame	004o	Washer	014	Idler Wheel, A
002	Head Assembly, Complete	004p	* Metal Fitting, Reel	015	Internal Wheel
002a	Erase Head	004q	Holder, Reel (Star Type Spring)	016a	Lever, A (with Lever E)
002b	Record/Playback Head	004r	Washer	016b	Shaft, Lever A
002c	Bias Head	004s	Washer Pin	016c	Spring, D
002d	z Spring, D	004t	Pulley B2, Reel	017a	Lever, B (with Lever D)
002e	Tape Guide (No. 17)	004u	Screw, without Head 4 x 7	017b	Cam Roller, A
002f	Tape Guide (N-3)	004v	Pulley C, Reel	017c	Cam Roller, B
002g	Tape Guide (N-2)	004w	Screw Flat 3 x 6	017d	Spring, B
002h	Table, Head	004x	Screw	018a	Lever, C3
002i	4T Cam	005	* Take-up Reel Assembly, Complete	018b	Spring, D
002j	Gear B, Head	005a	Take-up Roller, A	019a	Lever, G (with Lever H-D)
002k	Spring, Field Table	005b	Spring G (Right)	019b	Metal, Lever G
002l	Holder, Spring	005c	Take-up Roller, D	019c	Shaft B, Idler
002m	Nut, Head Lever	005d	Spring F 3	019d	Spring, Lever H-D
002n	Up-Down Table, Field	005e	Washer	020a	Lever, K
002o	Table, Field	005f	Washer	020b	Screw
002p	Spring, Field Table	005g	Set Sleeve	020c	Torsion Spring, D
002q	Micro Angle Table	005h	Screw, without Head 3 x 3.2	020d	Bush
002r	4T Shaft	005i	Nylon Tube	021a	Lever, FA
002s	Upper Plate, Head	006a	AS Lever, Complete	021b	Cam Roller, A
002t	Screw, Angle Adjustment	006b	Spring, AS Lever	022	Lever, F (for Motor)
002u	Plate, retaining Erase Head	006c	Plate, AS Lever (with Prop)	023	Lever, A2
002v	Plate, retaining Record/Playback Head	007a	Instant Stop Lever, A	024	Field Lever, A
002w	Side Plate, Bias Head	007b	Spring, Instant Stop Lever	025	Field Lever, B
002x	Rotary Switch	007c	Stopper, Instant Stop Lever	026	Field Lever, D
002y	Gear A, Head	007d	Holder B, Instant Stop Lever		
002z	4T Switch Table	007e	Screw, Retaining Instant Stop Lever		
		008a	Recording Safety Button		
		008b	Cam Stopper		
		008c	Fiber, Cam Stopper		
		008d	Insulator Plate, Cam Stopper		
		009a	Pinch Wheel		
		009b	Metal Cap, Pinch Wheel		
		009c	Screw, Pinch Wheel		

Parts No. Nomenclature

C2-027 Field Lever, E  
028 \* Prop, Panel  
029 Holder B, Spring  
030 Pin B, Spring  
031 Stopper C, Lever G  
032 Hum Bucking Coil  
033 Cycle Change Switch  
034 Micro Switch V-1A  
035 3P Lug Plate  
036 4P Jack  
038a Lever, Belt Change  
038b Stopper, Belt Change Lever  
038c Spring, Belt Change Lever  
038d Spring B, Belt Change Lever  
040 \* Table, Oscillator Card Block  
041 \* Voltage Adjustment Coil  
042 \* Tubular Type Electrolytic  
Condenser

### MOTOR BLOCK

C3-001 Motor, Complete  
001a + Screw Semi-Cubic 3 x 15  
001b Stepped Pulley  
001c Motor Pulley  
001d Holder L, Motor  
001f Motor Fan  
001g Screw, without Head  
001h Prop A, Motor  
001i Prop B, Motor  
001j \* MP Condenser 2  $\mu$  + 0.8  $\mu$   
250 VAC  
001k Holder, MP Condenser  
001l + Screw Flat Mould 4 x 50  
001m External Shield Plate, Motor  
002a \* MP Condenser 1  $\mu$  220 VAC  
002b 5P Lug Plate  
003 Drive Belt

### FLYWHEEL

C4-001 Flywheel, Complete  
001a Capstan  
001b Main Metal Cap, B  
001c Washer Pin  
001d Main Metal Case, B  
001e Spring, Main Metal

Parts No. Nomenclature

C4-001f Nylon Washer  
001g Main Shaft C  
001i 4mm Ball Bearing  
001j Nylon Plate  
001k Plate B, Flywheel  
001l Washer  
001m Spring Washer  
001n Washer  
001o 5mm Wing Nut  
001p Screw, Flywheel Adjustment  
001q 5mm Nut  
001r Prop B, Flywheel  
001s Prop A, Flywheel

### SWITCH BLOCK

C5-001 Switch Block, Complete  
001a \* Knob, Record/Play & Rewind  
Forward Fast  
001b \* Screw  
001c Cam, A 2  
001d Cam, B  
001e Cam Roller, A  
001f Switch Table, A  
001g Spring, E  
001h Lever, I  
001i Screw  
001j 4mm Nut  
001k Rotary Switch S-133-B  
001l Fast/Forward Rewind Shaft  
001m Plate, Cam  
001n Spring, K  
001o Cam, C  
001p + Screw Flat Mould 4 x 6  
001q Shield, Mechanism Switch  
001r Switch Table, B  
001s Washer  
001t Cam  
001u Washer  
001v Washer Pin  
002a Wired Resistor 5W 170  $\Omega$   
002b 5P Lug Plate

### CASE BLOCK

C6-001 \* Case  
002a Table, Rubber Foot  
002b Rubber Foot  
002c + Semi-Cubic 3 x 6  
003 \* Ventilator, A  
004 \* Ventilator, G  
005a \* Speaker Chassis, Left  
005b \* Speaker Chassis, Right  
006 Speed Nut

Parts No. Nomenclature

### AMPLIFIER

C7-001 Amp. Chassis  
001a Lug Plate, 2L2  
001b Lug Plate, 1L1  
001c Lug Plate, 1L  
002 \* Power Transformer (T-1)  
003a Holder, Jack  
003b Name Plate, Jack  
004a DIN Jack (J5)  
004b 2 Pole E1 Jack (J3)  
004c 2 Pole E Jack (J2)  
004d 2 Pole E1 Jack (J1) (Mic.)  
004e 3 Pole E Jack (J4) (Headphone)  
005 Toggle Switch ST-110A  
(Power Switch) (SW-1)  
006a Plate D, Jack  
006b Plate C, Jack  
007 Variable Resistor 50K  $\Omega$   
(A) (VR1)  
008 Rotary Switch F-243 (SW-9)  
008a Shield Holder  
009a Amplifier Lever, A  
009b Amplifier Lever, B  
009c Spring B  
010a Lamp Socket (Swan Type)  
010b Pilot Lamp  
011 \* VU Meter  
012a Holder D, Multi Jack  
012b 10P Multi Jack  
012c Prop, Multi Jack  
013a Resistor 1/4P 680K  $\Omega$  (R1)  
013b Resistor 1/4P 220K  $\Omega$  (R2)  
013c Resistor 1/4P 68K  $\Omega$  (R3)  
013d Wired Resistor 2W 82  $\Omega$   
(R5)  
013e Resistor 1WL 910  $\Omega$  (R4)  
013f Resistor 1/4P 4.7K  $\Omega$  (R8)  
013g Resistor 1/4P 15K  $\Omega$  (R9)  
014a Tubular Type Electrolytic  
Condenser 500  $\mu$ F 50WV (C1)  
014b Tubular Type Electrolytic  
Condenser 1000  $\mu$ F 25WV (C2)  
015 Holder, Card  
016 Shield  
017 Silicon Diode SW-05-01

Parts No.	Nomenclature
C7-018	Angle, Voltage Change
019	6P Slide Switch ESS-22A-NB (SW 3)
020	Name Plate, Cycle Change
021	Socket, Voltage Change
022	Hexangular Prop, Selector
023	Plug S, Voltage Change
024	Name Plate, AC Change
025	Closed Nut
026	2P Jack (J6)
027a	Fuse Post
027b	Fuse
028	Cord Support
029	Rubber Bush, AC Cord
030	AC Cord (10 Feet)
031	Chip Jack (J7)
032	4P Connector Socket (J9)
033	* Knob A (Rec. Level)
034	Knob B (Equalizer)
035	4P Connector Socket
<b>CARD BLOCK</b>	
CB 001	* Switch Block Card, Complete (CD 511)
002	* Printed Circuit Plate, Switch Block
003	* Slide Switch SL-1021 F
004a	* Inductance 3mH (J)
004b	* Inductance 47 mH (J)
005	* Diode IN 34 A (D 101)
006	* Transistor 2 SC 458 (B) (Tr 5)
007	* 4 P Plug
008a	* Resistor $\frac{1}{4}$ P 120 K $\Omega$ K (R 109)
008b	* Resistor $\frac{1}{4}$ P 68 K $\Omega$ K (R 101)
008c	* Resistor $\frac{1}{4}$ P 22 K $\Omega$ K ( $\frac{R 102, 103, 105, 106, 107, 108, 109, 110, 111, 112, 113, 114, 115, 116, 117, 118, 119, 120, 121, 122, 123, 124, 125, 126, 127, 128, 129, 130, 131, 132, 133, 134, 135, 136, 137, 138, 139, 140, 141, 142, 143, 144, 145, 146, 147, 148, 149, 150, 151, 152, 153, 154, 155, 156, 157, 158, 159, 160, 161, 162, 163, 164, 165, 166, 167, 168, 169, 170, 171, 172, 173, 174, 175, 176, 177, 178, 179, 180, 181, 182, 183, 184, 185, 186, 187, 188, 189, 190, 191, 192, 193, 194, 195, 196, 197, 198, 199, 200, 201, 202, 203, 204, 205, 206, 207, 208, 209, 210, 211, 212, 213, 214, 215, 216, 217, 218, 219, 220, 221, 222, 223, 224, 225, 226, 227, 228, 229, 230, 231, 232, 233, 234, 235, 236, 237, 238, 239, 240, 241, 242, 243, 244, 245, 246, 247, 248, 249, 250, 251, 252, 253, 254, 255, 256, 257, 258, 259, 260, 261, 262, 263, 264, 265, 266, 267, 268, 269, 270, 271, 272, 273, 274, 275, 276, 277, 278, 279, 280, 281, 282, 283, 284, 285, 286, 287, 288, 289, 290, 291, 292, 293, 294, 295, 296, 297, 298, 299, 300, 301, 302, 303, 304, 305, 306, 307, 308, 309, 310, 311, 312, 313, 314, 315, 316, 317, 318, 319, 320, 321, 322, 323, 324, 325, 326, 327, 328, 329, 330, 331, 332, 333, 334, 335, 336, 337, 338, 339, 340, 341, 342, 343, 344, 345, 346, 347, 348, 349, 350, 351, 352, 353, 354, 355, 356, 357, 358, 359, 360, 361, 362, 363, 364, 365, 366, 367, 368, 369, 370, 371, 372, 373, 374, 375, 376, 377, 378, 379, 380, 381, 382, 383, 384, 385, 386, 387, 388, 389, 390, 391, 392, 393, 394, 395, 396, 397, 398, 399, 400, 401, 402, 403, 404, 405, 406, 407, 408, 409, 410, 411, 412, 413, 414, 415, 416, 417, 418, 419, 420, 421, 422, 423, 424, 425, 426, 427, 428, 429, 430, 431, 432, 433, 434, 435, 436, 437, 438, 439, 440, 441, 442, 443, 444, 445, 446, 447, 448, 449, 450, 451, 452, 453, 454, 455, 456, 457, 458, 459, 460, 461, 462, 463, 464, 465, 466, 467, 468, 469, 470, 471, 472, 473, 474, 475, 476, 477, 478, 479, 480, 481, 482, 483, 484, 485, 486, 487, 488, 489, 490, 491, 492, 493, 494, 495, 496, 497, 498, 499, 500, 501, 502, 503, 504, 505, 506, 507, 508, 509, 510, 511, 512, 513, 514, 515, 516, 517, 518, 519, 520, 521, 522, 523, 524, 525, 526, 527, 528, 529, 530, 531, 532, 533, 534, 535, 536, 537, 538, 539, 540, 541, 542, 543, 544, 545, 546, 547, 548, 549, 550, 551, 552, 553, 554, 555, 556, 557, 558, 559, 560, 561, 562, 563, 564, 565, 566, 567, 568, 569, 570, 571, 572, 573, 574, 575, 576, 577, 578, 579, 580, 581, 582, 583, 584, 585, 586, 587, 588, 589, 590, 591, 592, 593, 594, 595, 596, 597, 598, 599, 600, 601, 602, 603, 604, 605, 606, 607, 608, 609, 610, 611, 612, 613, 614, 615, 616, 617, 618, 619, 620, 621, 622, 623, 624, 625, 626, 627, 628, 629, 630, 631, 632, 633, 634, 635, 636, 637, 638, 639, 640, 641, 642, 643, 644, 645, 646, 647, 648, 649, 650, 651, 652, 653, 654, 655, 656, 657, 658, 659, 660, 661, 662, 663, 664, 665, 666, 667, 668, 669, 670, 671, 672, 673, 674, 675, 676, 677, 678, 679, 680, 681, 682, 683, 684, 685, 686, 687, 688, 689, 690, 691, 692, 693, 694, 695, 696, 697, 698, 699, 700, 701, 702, 703, 704, 705, 706, 707, 708, 709, 710, 711, 712, 713, 714, 715, 716, 717, 718, 719, 720, 721, 722, 723, 724, 725, 726, 727, 728, 729, 730, 731, 732, 733, 734, 735, 736, 737, 738, 739, 740, 741, 742, 743, 744, 745, 746, 747, 748, 749, 750, 751, 752, 753, 754, 755, 756, 757, 758, 759, 760, 761, 762, 763, 764, 765, 766, 767, 768, 769, 770, 771, 772, 773, 774, 775, 776, 777, 778, 779, 780, 781, 782, 783, 784, 785, 786, 787, 788, 789, 790, 791, 792, 793, 794, 795, 796, 797, 798, 799, 800, 801, 802, 803, 804, 805, 806, 807, 808, 809, 810, 811, 812, 813, 814, 815, 816, 817, 818, 819, 820, 821, 822, 823, 824, 825, 826, 827, 828, 829, 830, 831, 832, 833, 834, 835, 836, 837, 838, 839, 840, 841, 842, 843, 844, 845, 846, 847, 848, 849, 850, 851, 852, 853, 854, 855, 856, 857, 858, 859, 860, 861, 862, 863, 864, 865, 866, 867, 868, 869, 870, 871, 872, 873, 874, 875, 876, 877, 878, 879, 880, 881, 882, 883, 884, 885, 886, 887, 888, 889, 890, 891, 892, 893, 894, 895, 896, 897, 898, 899, 900, 901, 902, 903, 904, 905, 906, 907, 908, 909, 910, 911, 912, 913, 914, 915, 916, 917, 918, 919, 920, 921, 922, 923, 924, 925, 926, 927, 928, 929, 930, 931, 932, 933, 934, 935, 936, 937, 938, 939, 940, 941, 942, 943, 944, 945, 946, 947, 948, 949, 950, 951, 952, 953, 954, 955, 956, 957, 958, 959, 960, 961, 962, 963, 964, 965, 966, 967, 968, 969, 970, 971, 972, 973, 974, 975, 976, 977, 978, 979, 980, 981, 982, 983, 984, 985, 986, 987, 988, 989, 990, 991, 992, 993, 994, 995, 996, 997, 998, 999, 1000$
008d	* Resistor $\frac{1}{4}$ P 15 K $\Omega$ K (R 107)
008e	* Resistor $\frac{1}{4}$ P 12 K $\Omega$ K (R 111)

Parts No.	Nomenclature
CB 008f	* Resistor $\frac{1}{4}$ P 10 K $\Omega$ K ( $\frac{R 106, 110, 111, 112, 113, 114, 115, 116, 117, 118, 119, 120, 121, 122, 123, 124, 125, 126, 127, 128, 129, 130, 131, 132, 133, 134, 135, 136, 137, 138, 139, 140, 141, 142, 143, 144, 145, 146, 147, 148, 149, 150, 151, 152, 153, 154, 155, 156, 157, 158, 159, 160, 161, 162, 163, 164, 165, 166, 167, 168, 169, 170, 171, 172, 173, 174, 175, 176, 177, 178, 179, 180, 181, 182, 183, 184, 185, 186, 187, 188, 189, 190, 191, 192, 193, 194, 195, 196, 197, 198, 199, 200, 201, 202, 203, 204, 205, 206, 207, 208, 209, 210, 211, 212, 213, 214, 215, 216, 217, 218, 219, 220, 221, 222, 223, 224, 225, 226, 227, 228, 229, 230, 231, 232, 233, 234, 235, 236, 237, 238, 239, 240, 241, 242, 243, 244, 245, 246, 247, 248, 249, 250, 251, 252, 253, 254, 255, 256, 257, 258, 259, 260, 261, 262, 263, 264, 265, 266, 267, 268, 269, 270, 271, 272, 273, 274, 275, 276, 277, 278, 279, 280, 281, 282, 283, 284, 285, 286, 287, 288, 289, 290, 291, 292, 293, 294, 295, 296, 297, 298, 299, 300, 301, 302, 303, 304, 305, 306, 307, 308, 309, 310, 311, 312, 313, 314, 315, 316, 317, 318, 319, 320, 321, 322, 323, 324, 325, 326, 327, 328, 329, 330, 331, 332, 333, 334, 335, 336, 337, 338, 339, 340, 341, 342, 343, 344, 345, 346, 347, 348, 349, 350, 351, 352, 353, 354, 355, 356, 357, 358, 359, 360, 361, 362, 363, 364, 365, 366, 367, 368, 369, 370, 371, 372, 373, 374, 375, 376, 377, 378, 379, 380, 381, 382, 383, 384, 385, 386, 387, 388, 389, 390, 391, 392, 393, 394, 395, 396, 397, 398, 399, 400, 401, 402, 403, 404, 405, 406, 407, 408, 409, 410, 411, 412, 413, 414, 415, 416, 417, 418, 419, 420, 421, 422, 423, 424, 425, 426, 427, 428, 429, 430, 431, 432, 433, 434, 435, 436, 437, 438, 439, 440, 441, 442, 443, 444, 445, 446, 447, 448, 449, 450, 451, 452, 453, 454, 455, 456, 457, 458, 459, 460, 461, 462, 463, 464, 465, 466, 467, 468, 469, 470, 471, 472, 473, 474, 475, 476, 477, 478, 479, 480, 481, 482, 483, 484, 485, 486, 487, 488, 489, 490, 491, 492, 493, 494, 495, 496, 497, 498, 499, 500, 501, 502, 503, 504, 505, 506, 507, 508, 509, 510, 511, 512, 513, 514, 515, 516, 517, 518, 519, 520, 521, 522, 523, 524, 525, 526, 527, 528, 529, 530, 531, 532, 533, 534, 535, 536, 537, 538, 539, 540, 541, 542, 543, 544, 545, 546, 547, 548, 549, 550, 551, 552, 553, 554, 555, 556, 557, 558, 559, 560, 561, 562, 563, 564, 565, 566, 567, 568, 569, 570, 571, 572, 573, 574, 575, 576, 577, 578, 579, 580, 581, 582, 583, 584, 585, 586, 587, 588, 589, 590, 591, 592, 593, 594, 595, 596, 597, 598, 599, 600, 601, 602, 603, 604, 605, 606, 607, 608, 609, 610, 611, 612, 613, 614, 615, 616, 617, 618, 619, 620, 621, 622, 623, 624, 625, 626, 627, 628, 629, 630, 631, 632, 633, 634, 635, 636, 637, 638, 639, 640, 641, 642, 643, 644, 645, 646, 647, 648, 649, 650, 651, 652, 653, 654, 655, 656, 657, 658, 659, 660, 661, 662, 663, 664, 665, 666, 667, 668, 669, 670, 671, 672, 673, 674, 675, 676, 677, 678, 679, 680, 681, 682, 683, 684, 685, 686, 687, 688, 689, 690, 691, 692, 693, 694, 695, 696, 697, 698, 699, 700, 701, 702, 703, 704, 705, 706, 707, 708, 709, 710, 711, 712, 713, 714, 715, 716, 717, 718, 719, 720, 721, 722, 723, 724, 725, 726, 727, 728, 729, 730, 731, 732, 733, 734, 735, 736, 737, 738, 739, 740, 741, 742, 743, 744, 745, 746, 747, 748, 749, 750, 751, 752, 753, 754, 755, 756, 757, 758, 759, 760, 761, 762, 763, 764, 765, 766, 767, 768, 769, 770, 771, 772, 773, 774, 775, 776, 777, 778, 779, 780, 781, 782, 783, 784, 785, 786, 787, 788, 789, 790, 791, 792, 793, 794, 795, 796, 797, 798, 799, 800, 801, 802, 803, 804, 805, 806, 807, 808, 809, 810, 811, 812, 813, 814, 815, 816, 817, 818, 819, 820, 821, 822, 823, 824, 825, 826, 827, 828, 829, 830, 831, 832, 833, 834, 835, 836, 837, 838, 839, 840, 841, 842, 843, 844, 845, 846, 847, 848, 849, 850, 851, 852, 853, 854, 855, 856, 857, 858, 859, 860, 861, 862, 863, 864, 865, 866, 867, 868, 869, 870, 871, 872, 873, 874, 875, 876, 877, 878, 879, 880, 881, 882, 883, 884, 885, 886, 887, 888, 889, 890, 891, 892, 893, 894, 895, 896, 897, 898, 899, 900, 901, 902, 903, 904, 905, 906, 907, 908, 909, 910, 911, 912, 913, 914, 915, 916, 917, 918, 919, 920, 921, 922, 923, 924, 925, 926, 927, 928, 929, 930, 931, 932, 933, 934, 935, 936, 937, 938, 939, 940, 941, 942, 943, 944, 945, 946, 947, 948, 949, 950, 951, 952, 953, 954, 955, 956, 957, 958, 959, 960, 961, 962, 963, 964, 965, 966, 967, 968, 969, 970, 971, 972, 973, 974, 975, 976, 977, 978, 979, 980, 981, 982, 983, 984, 985, 986, 987, 988, 989, 990, 991, 992, 993, 994, 995, 996, 997, 998, 999, 1000$
008g	* Resistor $\frac{1}{4}$ P 5.6 K $\Omega$ K (R 104)
008h	* Resistor $\frac{1}{4}$ P 2.7 K $\Omega$ K (R 112)
008i	* Resistor $\frac{1}{4}$ P 1 K $\Omega$ K (R 108)
009	* Variable Resistor V-10 K 5 2 K $\Omega$ B
010a	* Condenser 3 $\mu$ 25 V (C 108)
010b	* Condenser 10 $\mu$ 10 V (C 110)
010c	* Condenser 30 $\mu$ 3 V (C 111)
010d	* Condenser 330 PF 35 V K (C 102)
010e	* Condenser 0.01 $\mu$ 50 V K (C 105)
010f	* Condenser 0.012 $\mu$ 50 V J (C 103)
010g	* Condenser 0.015 $\mu$ 50 V K (C 106)
010h	* Condenser 0.022 $\mu$ 50 V K (C 109)
010i	* Condenser 0.056 $\mu$ 50 V K (C 107)
010j	* Condenser 0.15 $\mu$ 35 V K (C 101)
010k	* Condenser 120 PF (J) (C 104)
010l	* Condenser 220 PF 125 V (K)
<b>PRE-AMPLIFIER</b>	
C9 001	* Record/Playback Pre-amplifier Card, Complete (CD 512)
002	* Printed Circuit Plate, Record/Playback Pre-amplifier
003a	* Transistor 2 SC 650 (A) (Tr 1, 2)
003b	* Transistor 2 SC 281 (B) (Tr 3, 4)
004a	* Resistor $\frac{1}{4}$ P 220 $\Omega$ K (R 205)
004b	* Resistor $\frac{1}{4}$ P 3.3 K $\Omega$ K (R 204)
004c	* Resistor $\frac{1}{4}$ P 4.7 K $\Omega$ K ( $\frac{R 207, 211, 212, 213, 214, 215, 216, 217, 218, 219, 220, 221, 222, 223, 224, 225, 226, 227, 228, 229, 230, 231, 232, 233, 234, 235, 236, 237, 238, 239, 240, 241, 242, 243, 244, 245, 246, 247, 248, 249, 250, 251, 252, 253, 254, 255, 256, 257, 258, 259, 260, 261, 262, 263, 264, 265, 266, 267, 268, 269, 270, 271, 272, 273, 274, 275, 276, 277, 278, 279, 280, 281, 282, 283, 284, 285, 286, 287, 288, 289, 290, 291, 292, 293, 294, 295, 296, 297, 298, 299, 300, 301, 302, 303, 304, 305, 306, 307, 308, 309, 310, 311, 312, 313, 314, 315, 316, 317, 318, 319, 320, 321, 322, 323, 324, 325, 326, 327, 328, 329, 330, 331, 332, 333, 334, 335, 336, 337, 338, 339, 340, 341, 342, 343, 344, 345, 346, 347, 348, 349, 350, 351, 352, 353, 354, 355, 356, 357, 358, 359, 360, 361, 362, 363, 364, 365, 366, 367, 368, 369, 370, 371, 372, 373, 374, 375, 376, 377, 378, 379, 380, 381, 382, 383, 384, 385, 386, 387, 388, 389, 390, 391, 392, 393, 394, 395, 396, 397, 398, 399, 400, 401, 402, 403, 404, 405, 406, 407, 408, 409, 410, 411, 412, 413, 414, 415, 416, 417, 418, 419, 420, $

## X. EXPLODED VIEW OF COMPONENT PARTS

### CASE

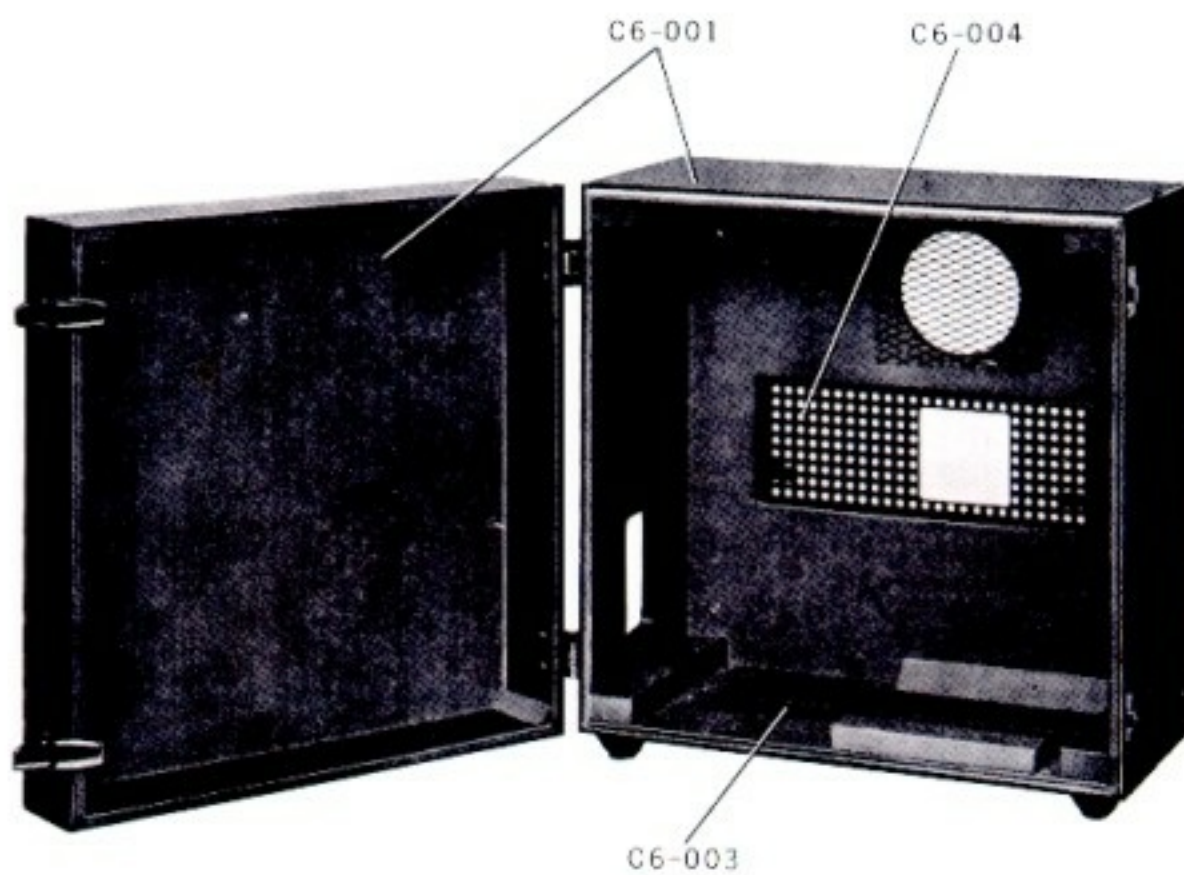

### FRONT PANEL

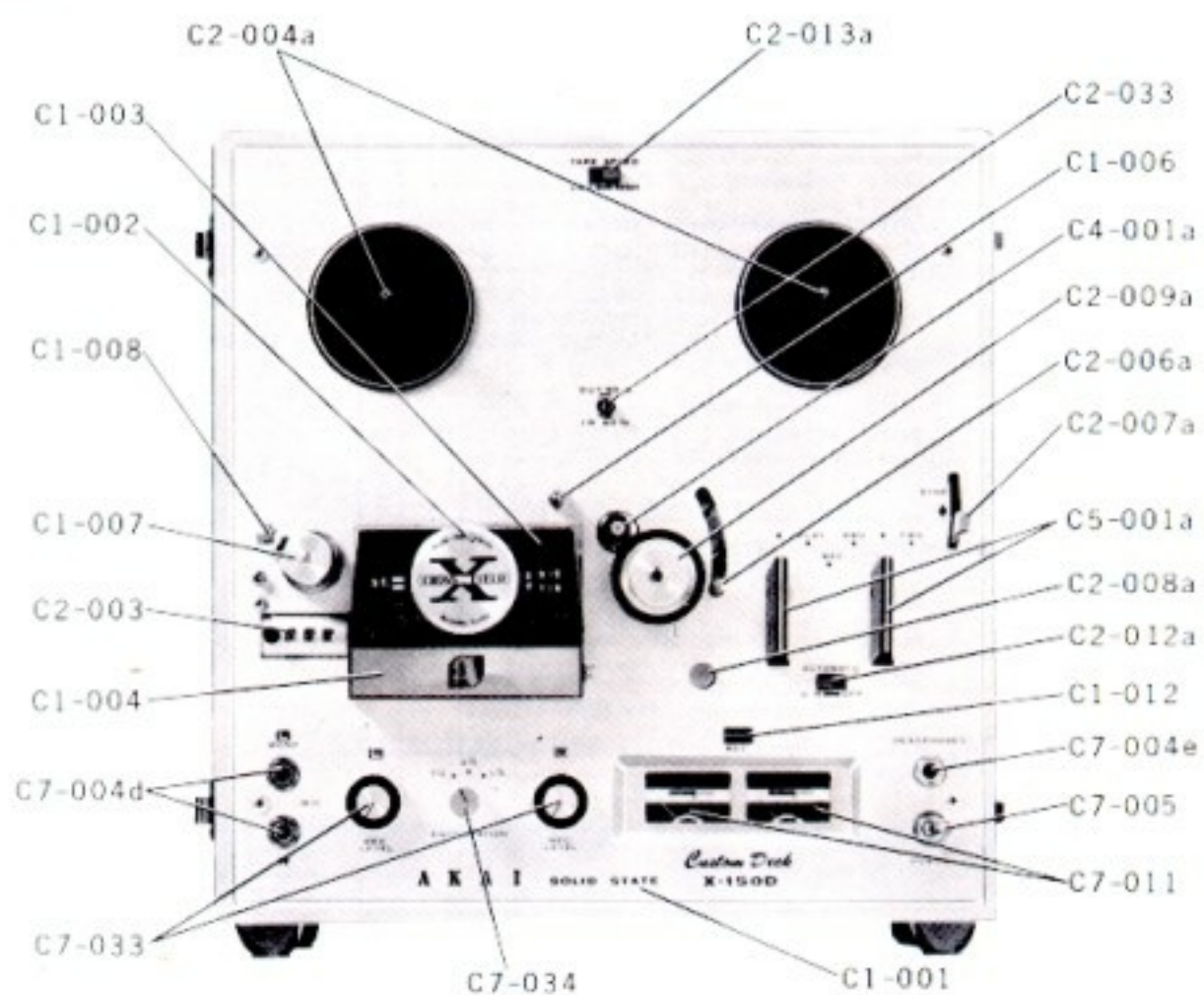

## AMPLIFIER - 1

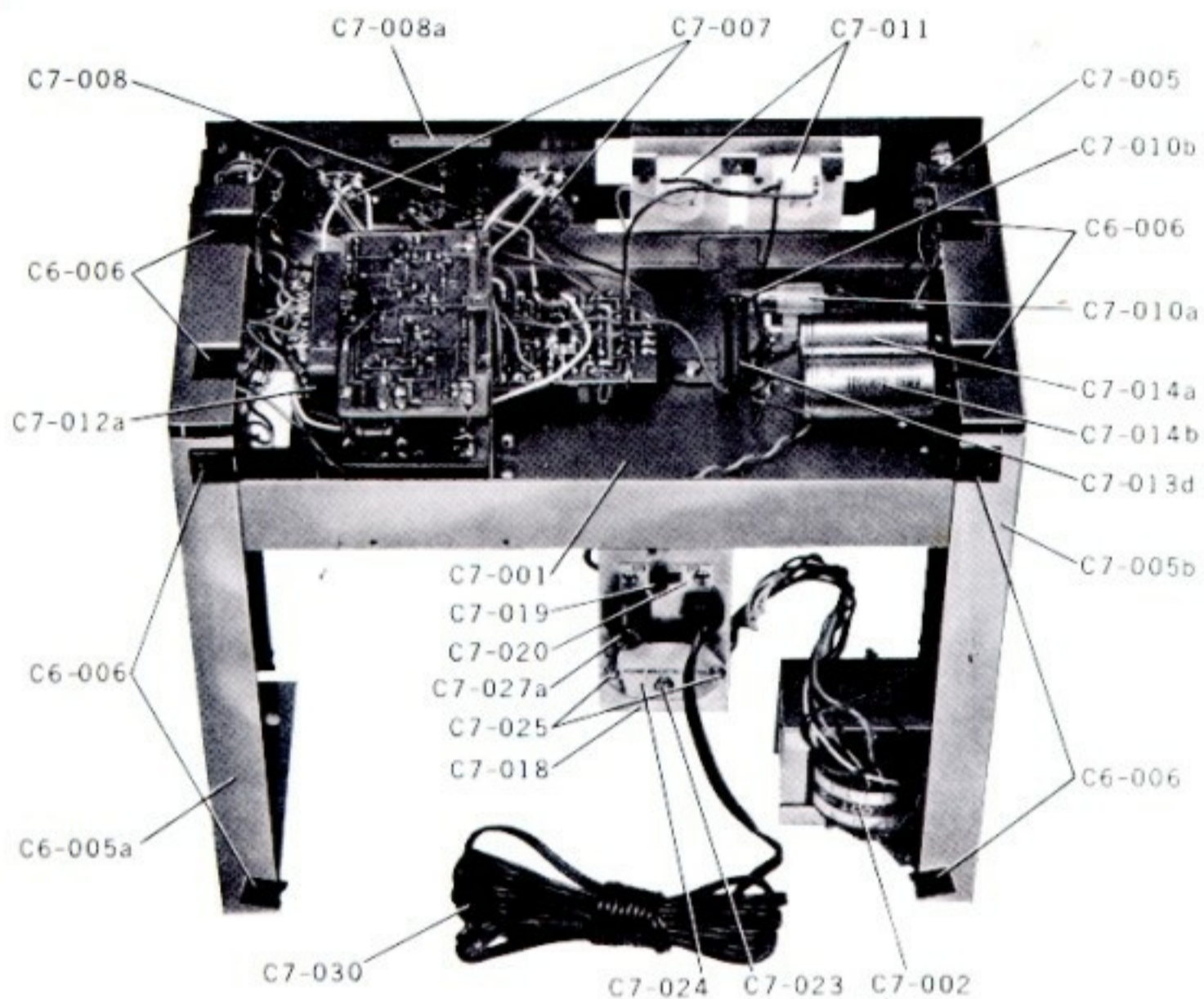

## AMPLIFIER - 2

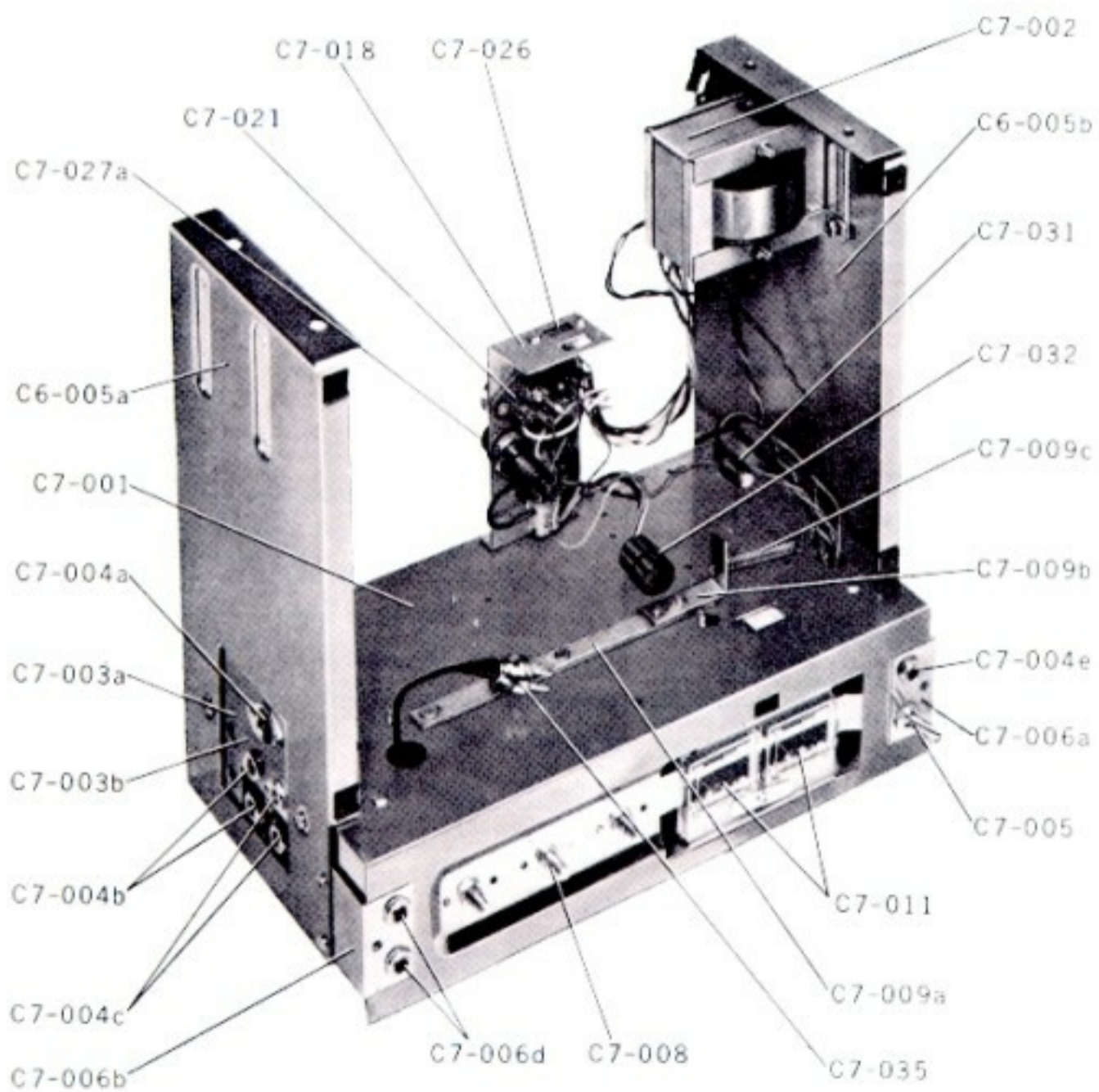

# Card Block - 1

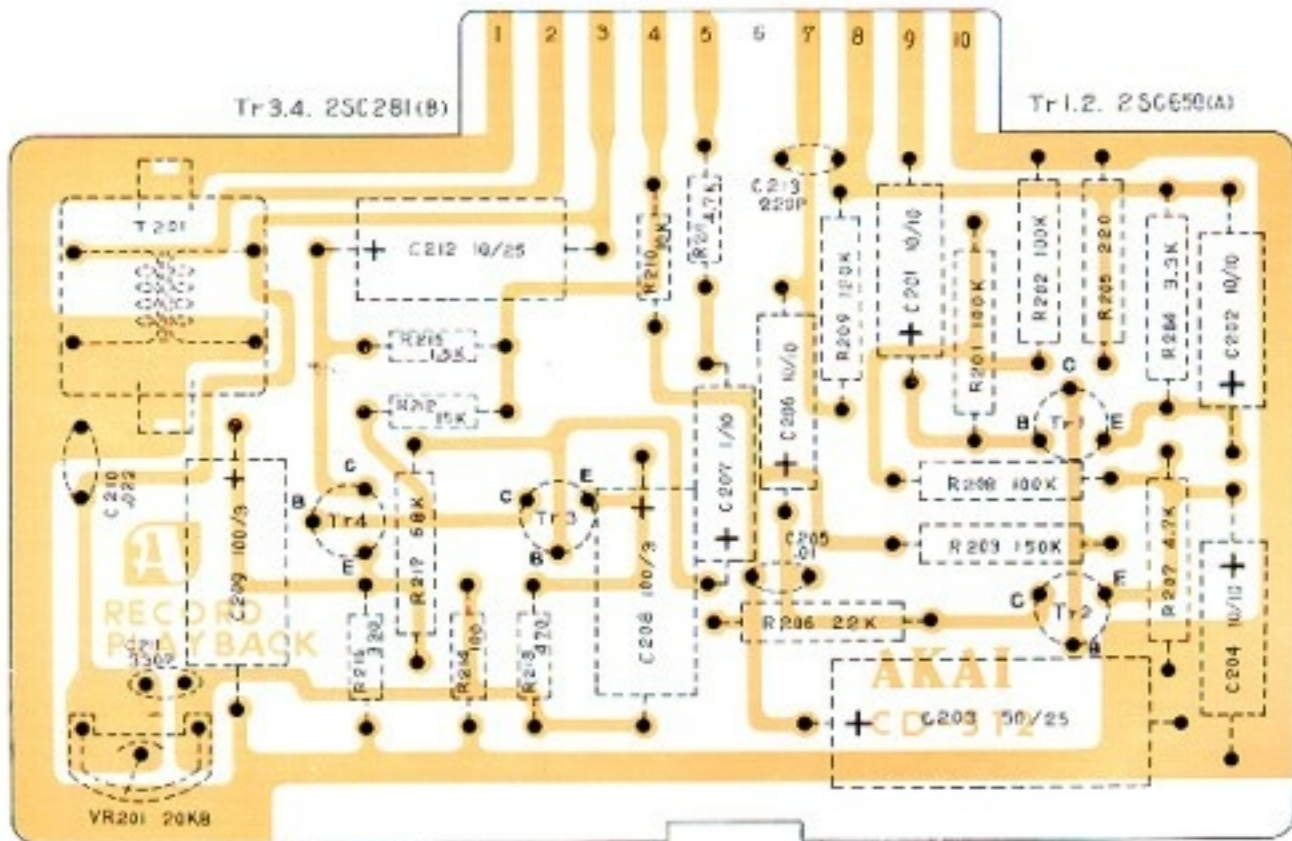
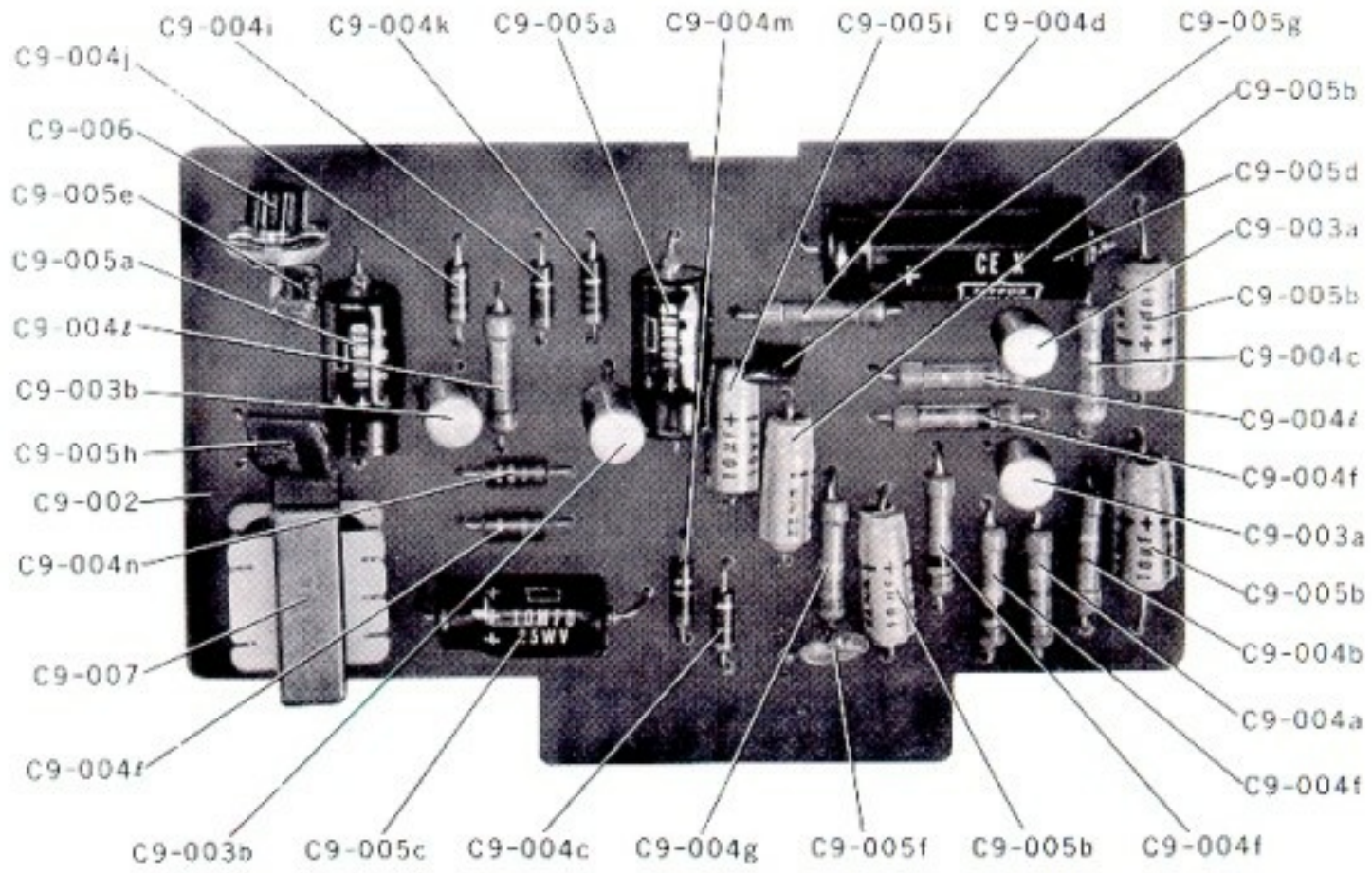



**Card Block - 3**

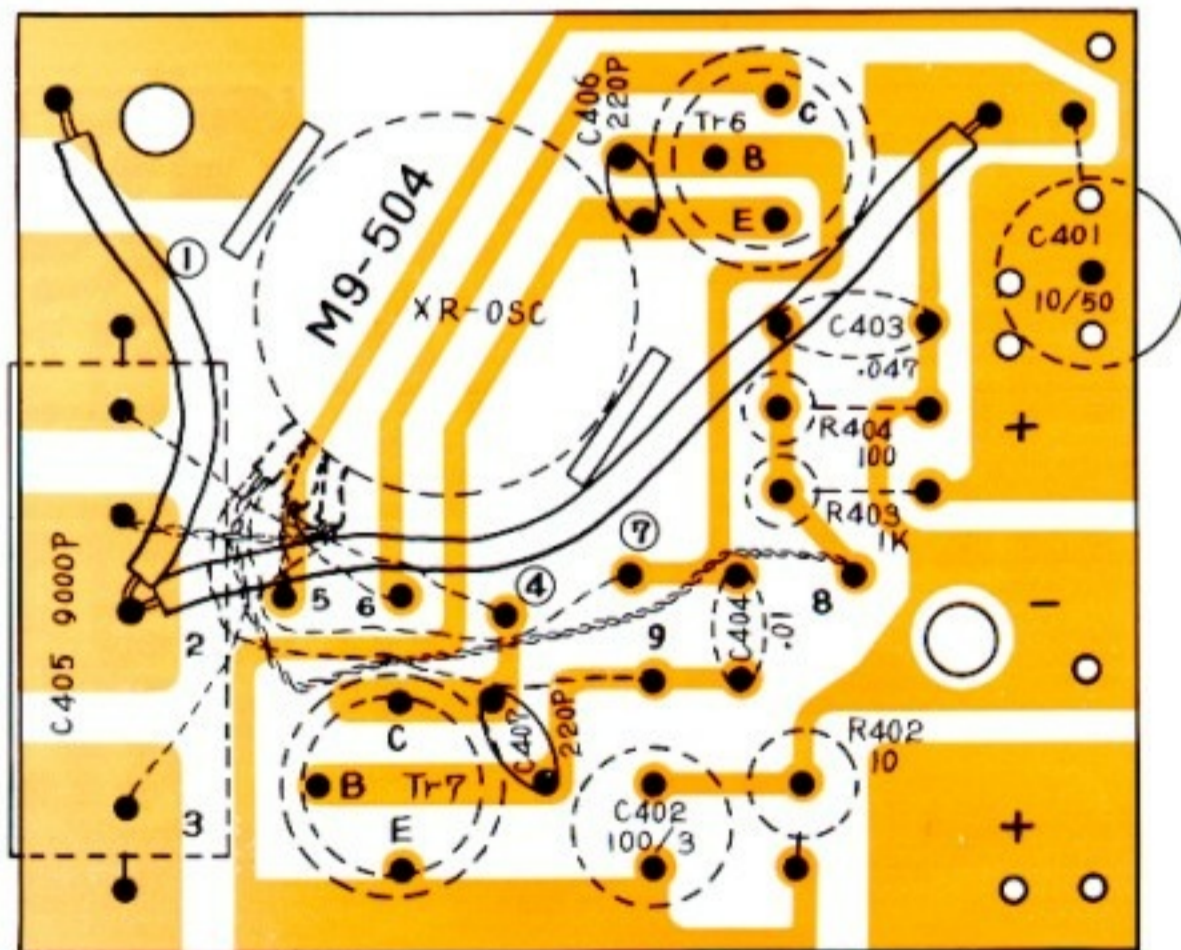
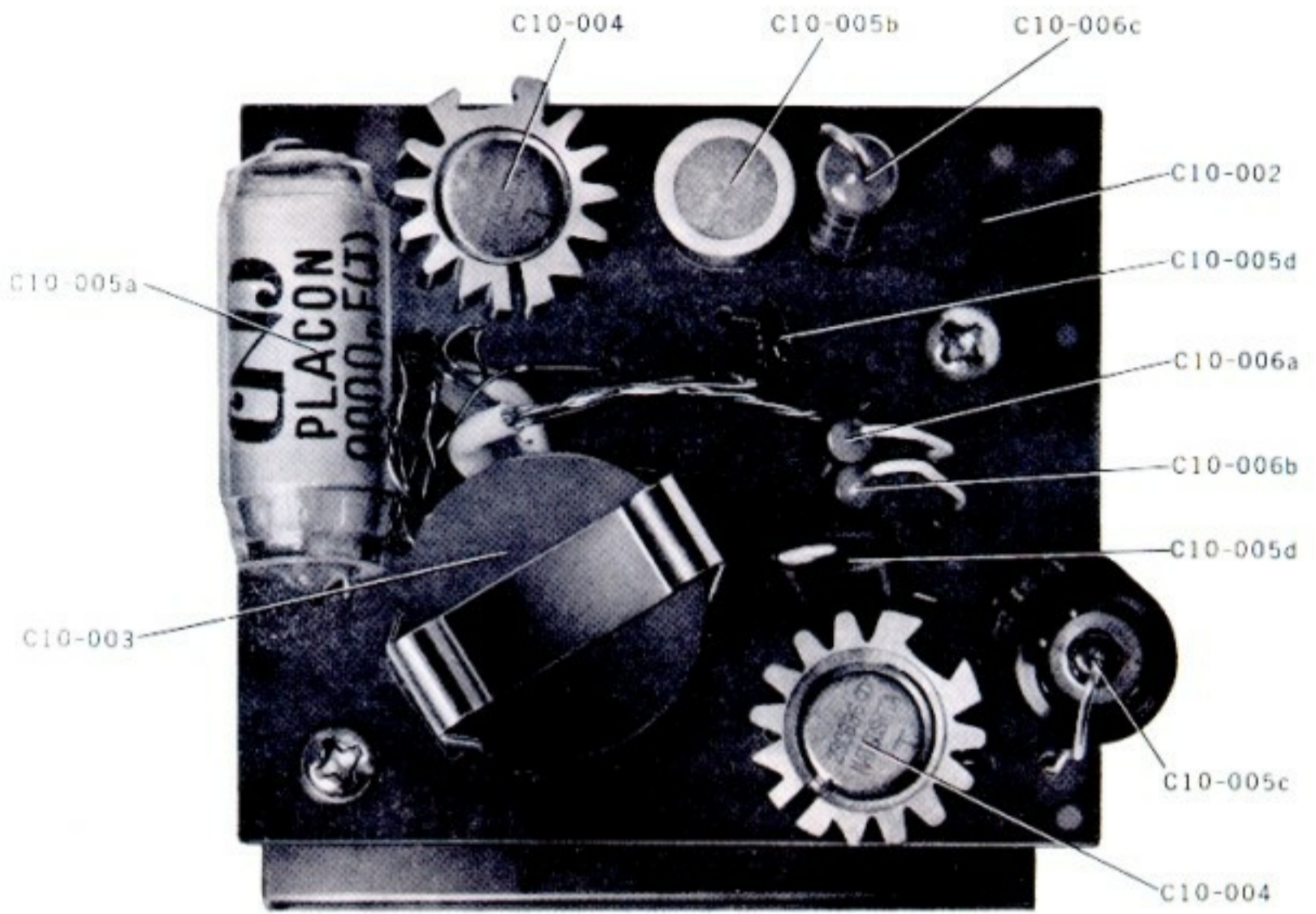

Tr 6, 7. 2SC696(J)(IXF)



# XI. TROUBLE SHOOTING CHART

## SECTION "A" TROUBLES WITH AMPLIFIER

### 1. Playback problems. (Unit set in play position.)

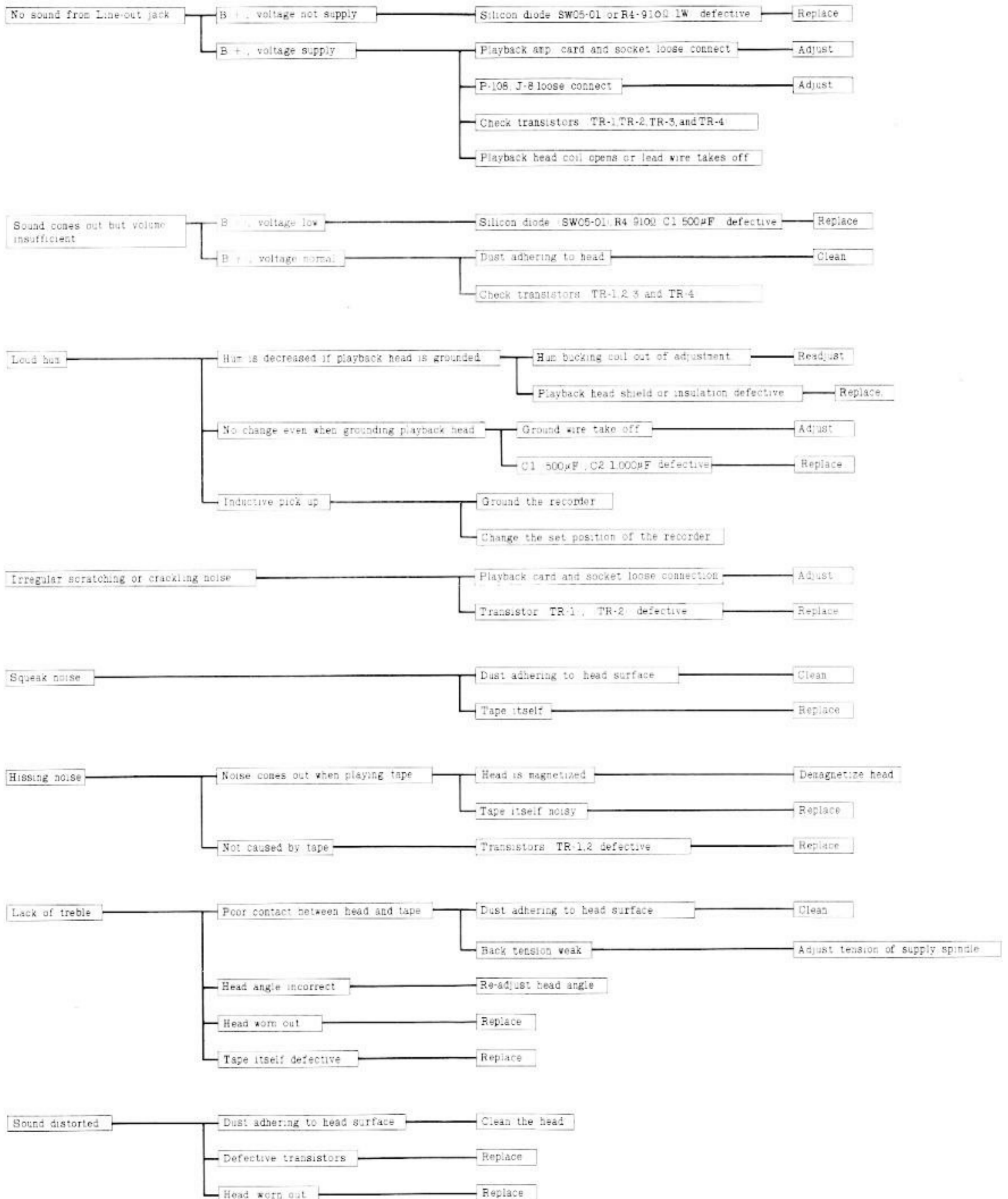

## 2. Recording problems.

(Unit plays back pre-recorded tapes okay, but recording not satisfactory.)

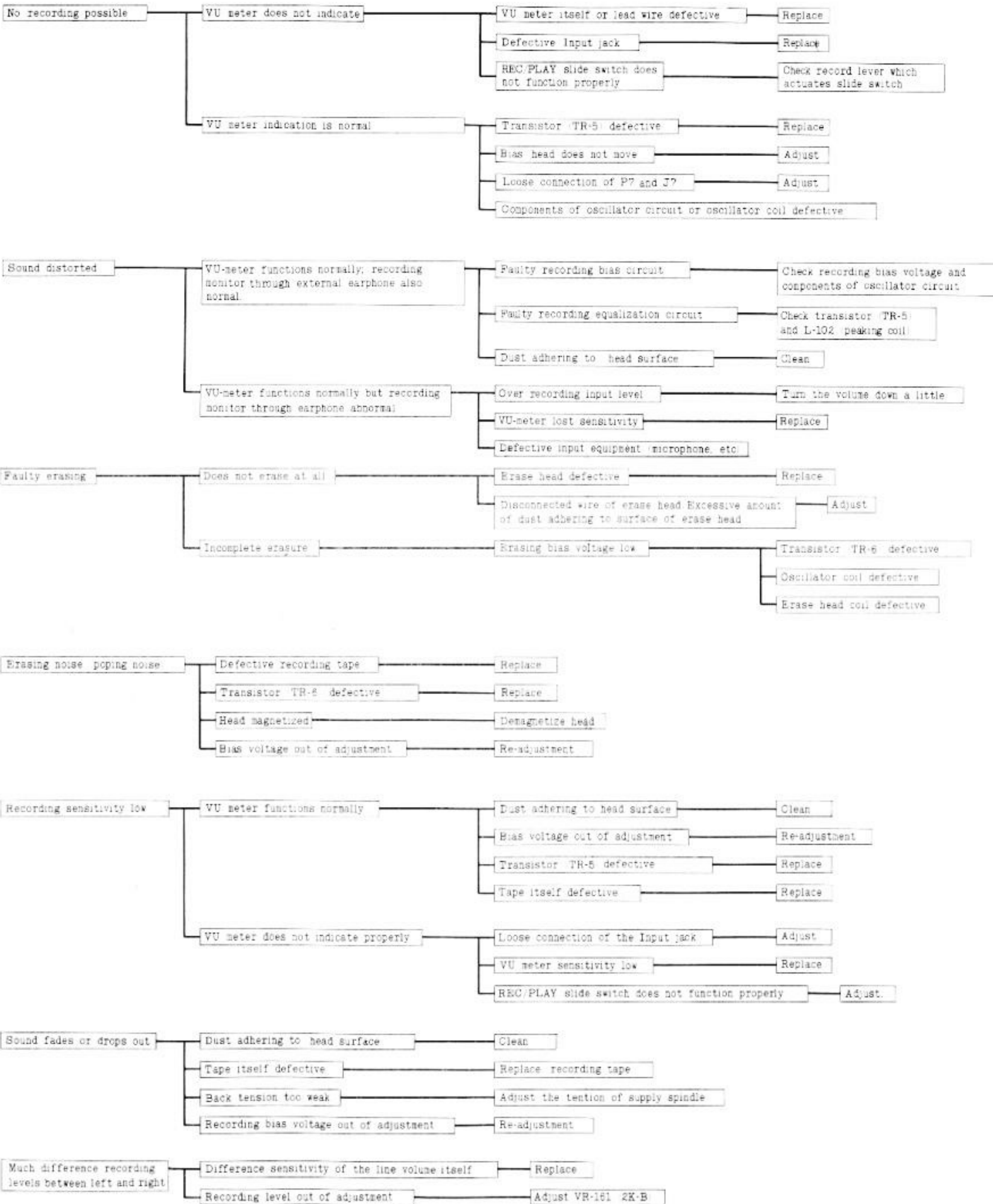

# SECTION "B" TROUBLES WITH TAPE TRANSPORT MECHANISM.



# SECTION "B" TROUBLES WITH TAPE TRANSPORT MECHANISM.

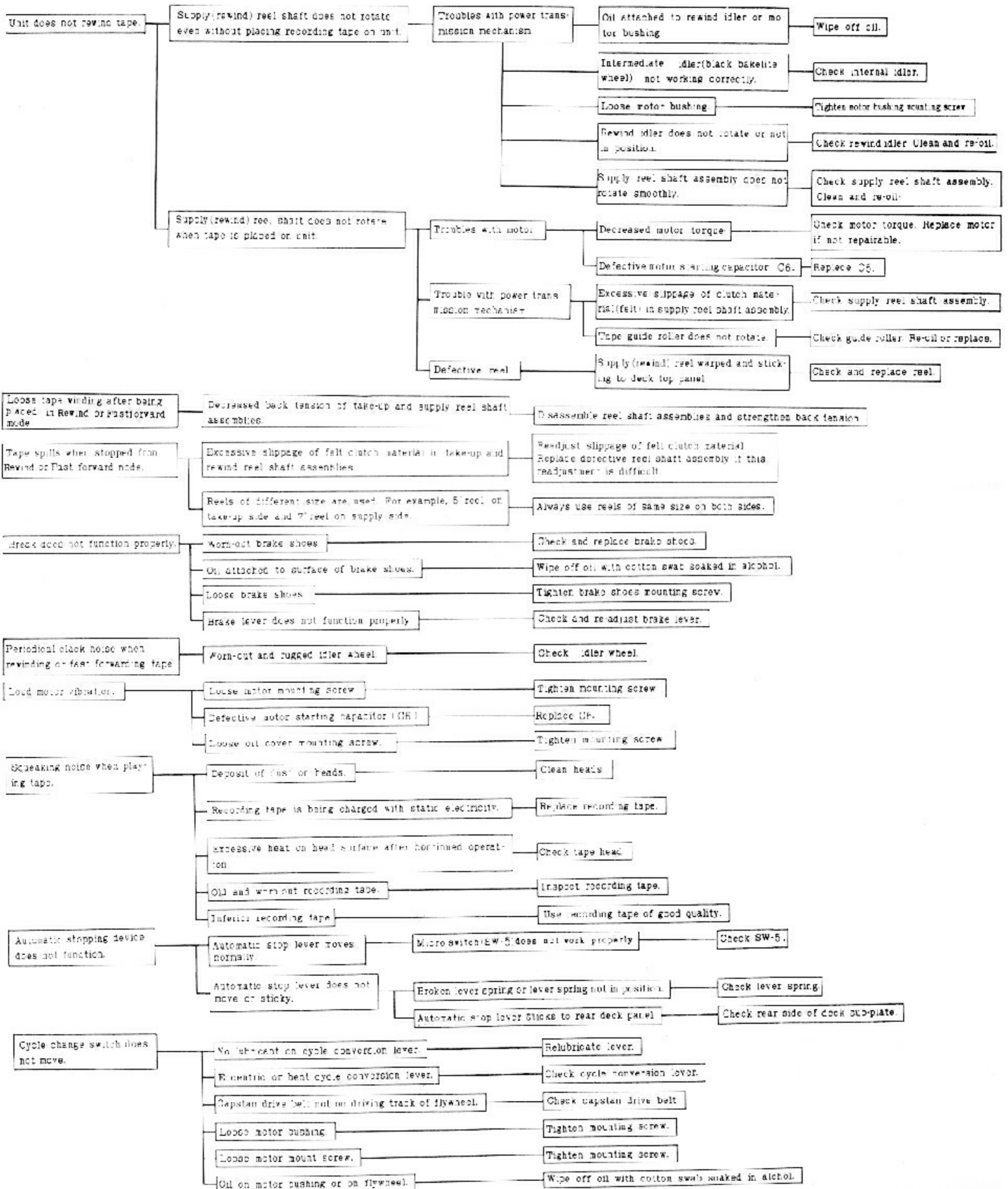

### XIII. CONNECTING DIAGRAM

