

# FULL AUTOMATIC STEREO TURNTABLE SYSTEM

# PS-X6/X7

*US Model*  
*Canadian Model*  
*AEP Model*  
*UK Model*  
*E Model*

## SUPPLEMENT

File this supplement with the service manual.

No. 2  
May, 1978

### CIRCUIT DESCRIPTION

#### TABLE OF CONTENTS

	<u>Title</u>	<u>Page</u>
1.	Operation of Servo Amplifier Circuit .....	2
2.	Maintaining Forward Rotation .....	4
3.	System Control Circuit .....	6
	3-1. Operation when POWER Switch is turned on .....	6
	3-2. Operation during Auto-start .....	8
	3-3. Operation if START/STOP Switch (S5) is touched during Play .....	9
	3-4. Operation during Auto-return .....	11
	3-5. Repeat Operation .....	13
	3-6. Operation if START/STOP Switch is touched during Lead-in .....	15
4.	Hall Motor .....	17

**SONY**<sup>®</sup>  
**SERVICE MANUAL**

**1. Operation of Servo Amplifier Circuit (See Fig. 1-1)**

**During Motor Start**

1. When the power switch is turned on, Q202 is still turned off since an output signal from the MG head is not applied to IC1-2. C204 will thus charge up through R210, R209 and RV201 (or R208 and RV201 for 45 rpm).
2. Once the emitter voltage of Q203 (charging voltage applied to the base of Q203) exceeds  $+V_{BE}$ , this transistor turns on.
3. Q205 is thus turned on, thereby applying a voltage to IC1-1.

**Limiter Circuit**

1. Once the turntable starts to rotate, an output signal is produced by the MG head.
2. Although the MG head output signal is a sine wave, there is some fluctuation in amplitude. Therefore, above a certain level, this sine wave is changed into a constant-amplitude square wave.

**Waveform Rectification**

1. The IC1-2 output signal is amplified by Q201 to obtain a complete square wave signal. The D201 is employed to maintain the base voltage of Q201 at  $\pm 0.6V_{p-p}$ .

2. This limiter circuit (IC1-2, Q201) serves to prevent incorrect detection of amplitude fluctuations as frequency changes.
3. The square wave signal on the collector of Q201 is then applied to the phase control circuit.

**Differential Circuit**

The square wave signal on the collector of Q201 is changed to a triangular wave by C203, R206 and R207. The differentiated (triangular) pulse triggers the sawtooth wave generator transistor (Q202).

**Sawtooth Wave Generator Circuit**

1. While Q202 is turned off, C204 is charged up through R210, R209 and RV201 (or R208 and RV201 for 45 rpm). But when the positive part of the differentiated wave turns Q202 on, C204 discharges immediately, resulting in the collector voltage of Q202 dropping to 0V.
2. After the  $\oplus$  portion of this differentiated wave has passed on, Q202 is again turned off, and C204 is charged up, resulting in the Q203 base voltage forming a sawtooth wave signal.

**Comparator**

1. The sawtooth wave signal is applied to the comparator circuit formed by Q203 and Q204. The base of Q204 is biased by the reference voltage produced by voltage division of B+ by the output from R213, R214, R215 and the phase control circuit.

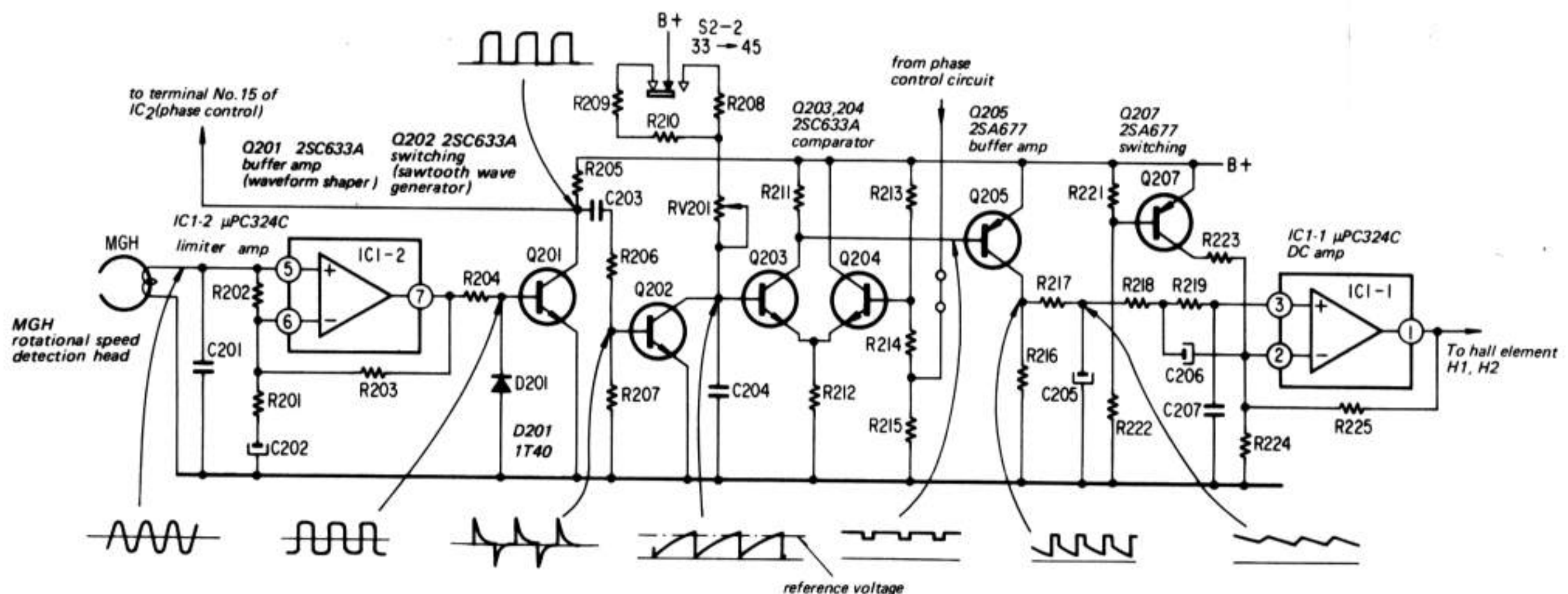

Fig. 1-1.



Since the emitter voltage of Q203 is determined at this time by the reference voltage, Q203 turns on when its base voltage (sawtooth wave) exceeds the total voltage (emitter voltage plus  $+V_{BE}$ ). So a negative pulse will appear on the collector of Q203.

2. If the rotational speed slows down, the frequency of the sawtooth wave will be low. Also, the output pulse width increases, because the on-time of Q203 becomes long. On the other hand, if the rotational speed increases, the frequency of the sawtooth wave will be high. Also, the output pulse width becomes narrow, because the on-period of Q203 becomes short.

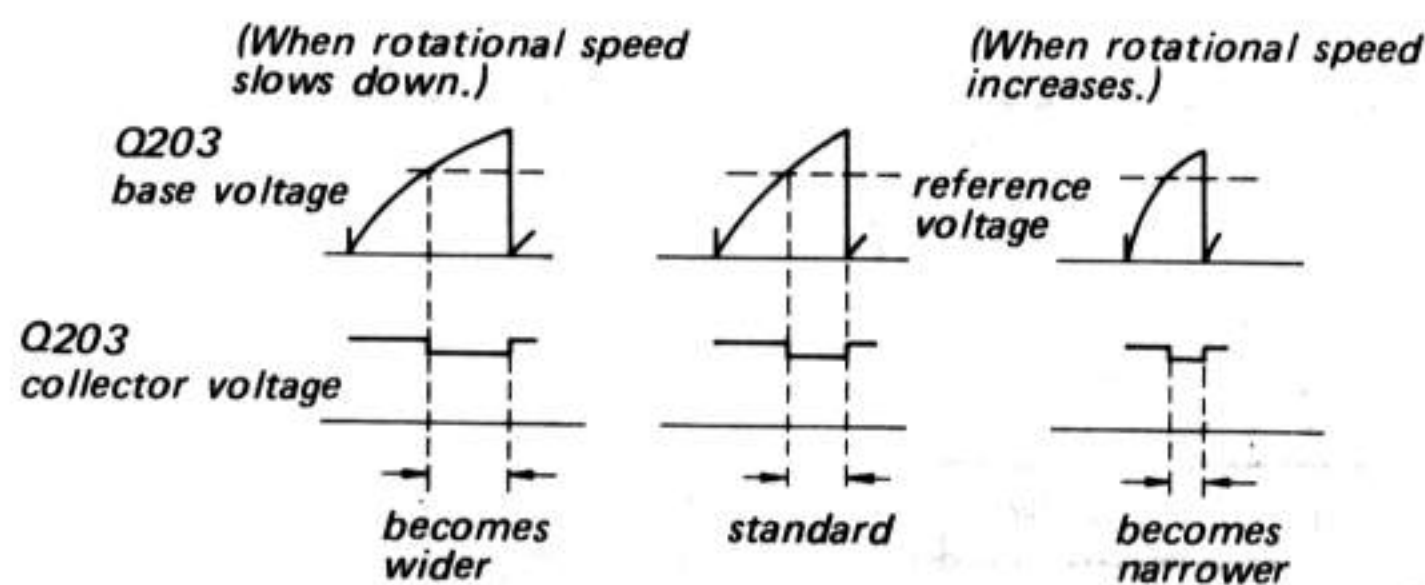

Fig. 1-2.

**Pulse Signal Amplifier**

Besides amplifying pulse signals, Q205 also serves as a phase inverter which feeds positive pulse signals to the next stage.

**Smoothing Circuit (low-pass filter)**

This smoothing circuit has two filters (one is made up of R217 and C205, and the other is IC1-1, R218, R219, C206 and C207). These filters operate as an integrating circuit which converts the pulse signals into dc signals (the voltage level being in proportion to pulse width).

**DC Amplifier Circuit**

The dc amplifier (that also serves as a low-pass filter), uses IC1-1, and amplifies the dc output signals from the previous stage.

**Speed Selector Switch (S2)**

1. The circuit time constant is changed by simply changing the resistance connected to the base of Q203.

2. The time constant for 45 rpm is designed to be faster than that for 33 rpm.
3. Consequently, when switching the speed selector switch from 33 to 45 rpm, the collector output pulse width of Q205 is widened, thereby increasing the level of the low-pass filter DC output signal. Motor speed is thus increased, followed by re-application of the servo control mechanism.
4. When switching back to 33 rpm, the reverse sequence of events takes place.

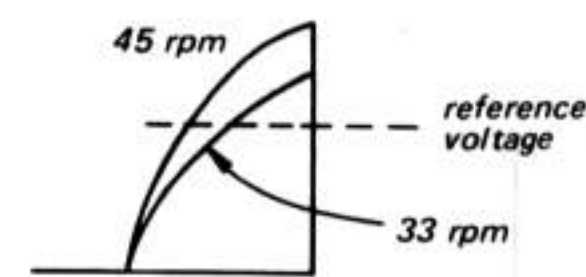

Fig. 1-3.

**Servo Control**

If for any reason, motor speed decreases or increases, even by the slightest degree, the servo control mechanism is activated to correct for the deviation, and returns the speed to the reference standard value.

1. If the motor speed is decreased slightly, the frequency of the MG head output signal decreases. This signal is applied to the phase control circuit (IC2) for phase comparison. The resultant output, of decreased voltage level, is then sent to the servo control. And since the base voltage of Q204 is reduced, the emitter voltage (reference voltage) of Q203 also decreases, resulting in the width of the Q203 collector output pulse being widened.
2. The dc output voltage from the low-pass filter consequently decreases, thereby increasing motor speed back to the original standard value.
3. If, on the other hand, motor speed is increased by some external influence, the servo control mechanism reduces speed in the reverse manner of that described above.

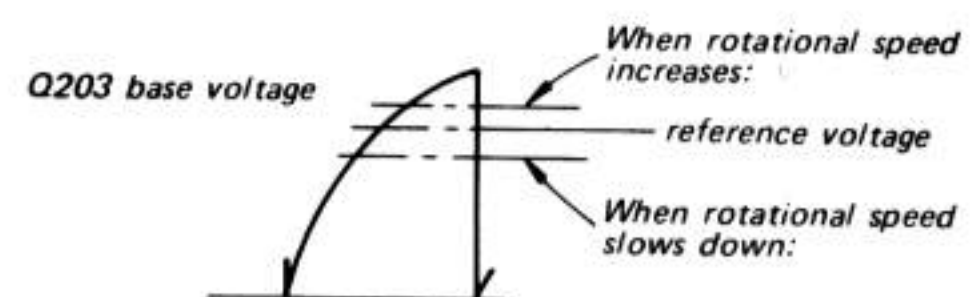

Fig. 1-4.



**2. Maintaining Forward Rotation (See Fig. 2-3)**

1. When a ⊕ signal is applied to the input terminal of the Hall elements, the motor is turned in the forward direction, but when a ⊖ signal is applied, the motor is turned in the reverse direction. Therefore, the reverse rotation that is caused by applying ⊖ input serves as a brake for rapid stopping of the turntable. (Conventional speed reduction systems use the phenomenon of hysteresis loss or mechanical loss.)

**2. F-V converter circuit**

This circuit converts the frequency of the MG head output signal into a voltage signal in accordance with the curve as shown in Fig. 2-1.

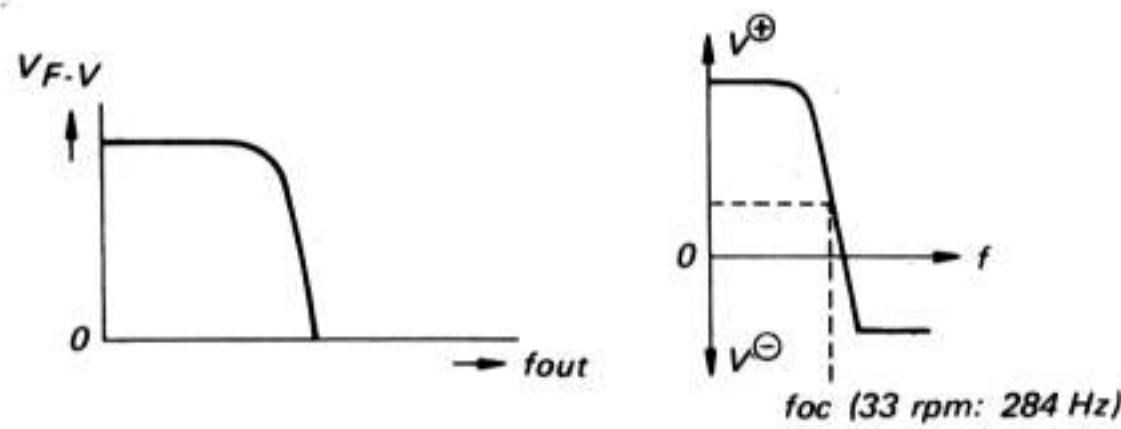

Fig. 2-1.

Fig. 2-2.

This curve shows “frequency against output voltage” for both forward and reverse rotations.

**3. DC amplifier (IC1-1) operation**

The output level of IC1-1 is determined by the relationship:

$$V_{OUT} = (V^{\oplus}_{IN} - V^{\ominus}_{IN}) \times \text{Gain},$$

or  $V_{OUT} = V^{\oplus}_{IN} \times \text{Gain}$  when  $V^{\ominus}_{IN}$  is 0V.

In this equipment, output levels of approx. -1.5V to +13V are possible by applying ⊕ voltage to  $V^{\ominus}_{IN}$  through Q207 and R223.

When the speed selector is instantly switched from 45 rpm to 33 rpm,  $V^{\oplus}_{IN}$  becomes 0V,  $V^{\ominus}_{IN}$  becomes positive, and  $V_{OUT}$  minus, thereby activating the brake operation.

4. If the frequency of the MG head exceeds  $f_{oc}$  during forward rotation,  $V_{OUT}$  becomes 0 or minus, thereby slowing down rotational speed. But during reverse rotation, the result is an acceleration of the reverse rotational action.
5. In order to prevent such “run-away” acceleration, a switching circuit consisting of Q210, Q209, and Q208 is employed, thus maintaining forward rotation.

**Normal Operation**

1. For normal operation, the emitter of Q210 is fixed to a level of -0.5V by D203.

2. Since the base potential of Q210 is normally kept at about 1.5V, Q210 turns on.
3. Since the base of Q209 is -0.5V, Q209 turns off. Q208 also turns off, and then Q207 turns on.
4. A ⊕ signal is thereby applied to the ⊖ input terminal of IC1-1 through R223.

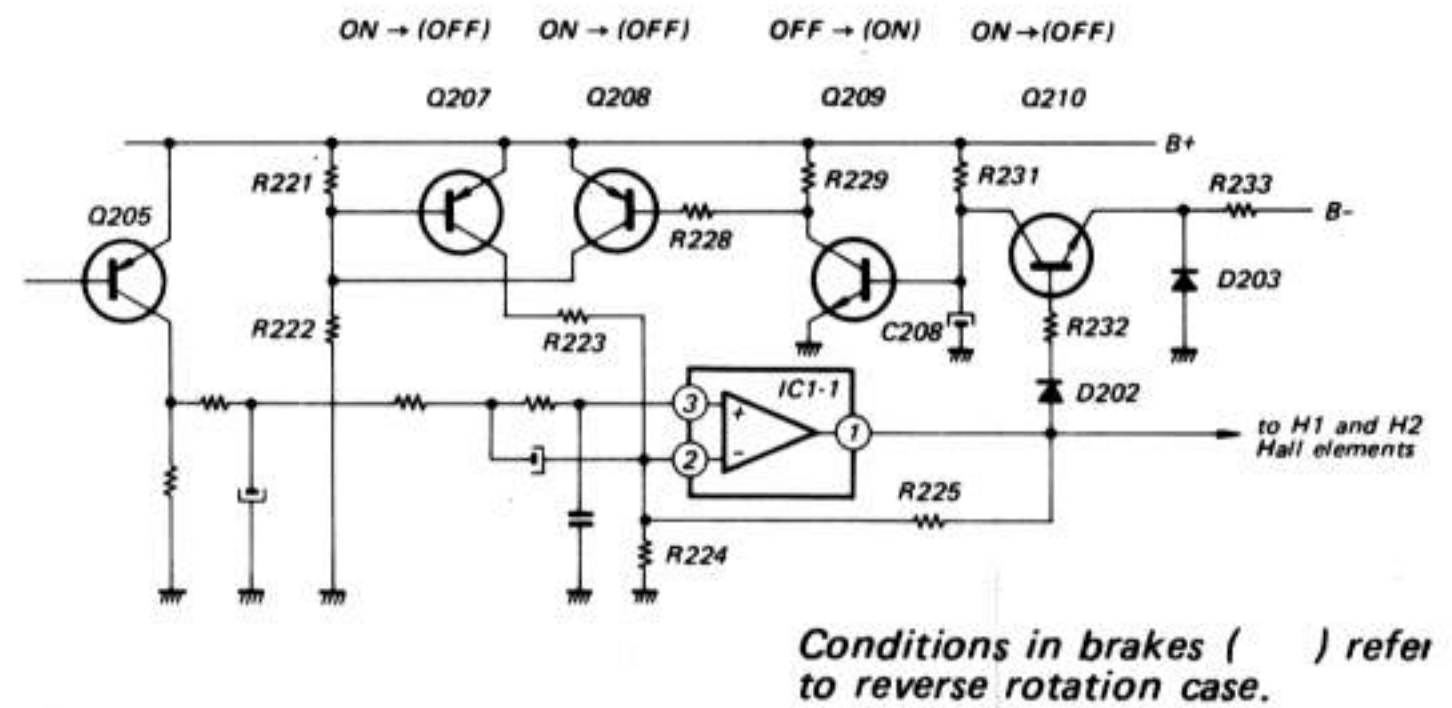

Fig. 2-3.

**Reverse Rotation**

1. When operating too fast during reverse rotation (when the frequency of the MG head output signal exceeds  $f_{oc}$ ), Q205 is turned off and no signal is obtained on the ⊕ input terminal of IC1-1. The output level of IC1-1 then drops from the normal 1.5V (relative to ground) to less than +0.5V, resulting in Q210 being turned off.
2. Consequently, the base voltage of Q209 rises in accordance with the R231/C208 time constant, finally turning Q209 on once the base potential exceeds +0.5V.
3. Q208 then turns on, and Q207 turns off.
4. Consequently, no voltage is applied to the ⊖ input terminal of IC1-1.
5. That is, the operation of IC1-1 will be stopped, resulting in the output level reducing to 0V, and the slowing down of rotational speed.
6. The MG head output frequency consequently drops below  $f_{oc}$ , resulting in a positive output signal from the F-V converter, and forward motor rotation. Once the IC1-1 output level exceeds +0.5V, the reverse-rotation prevention circuit is put into standby status.
7. This reverse rotation prevention circuit can be switched off again extremely rapidly. When Q210 is turned on, C208 discharges through R233 to the B- bus.

**Stroboscope**

The stroboscope system employed in this equipment consists of stroboscope stripes marked on the outer rim of the turntable platter, plus a neon lamp directed onto the outer rim stripes. The number of stroboscope stripes for 33 1/3 rpm and 45 rpm are determined by the following equation:

$$n = \frac{60(m + 2f)}{N}$$

where  $n$  = number of stripes,  
 $m$  = the number of stripes to pass any one point during 1 second,  
 $f$  = power supply frequency (Hz),  
 and  $N$  = turntable speed (rpm).

**Table 1**

RPM	Number of stroboscope stripes	
	50 Hz	60 Hz
33 1/3	180	216
45	133 1/3	160

As can be seen from this table, the above equation does not give an integral number of stripes for the 45 rpm speed at 50 Hz.

Therefore, the strips of the stroboscope are difficult to judge at 50 Hz, 45 rpm. However, this speed error can be ignored while a record is being played. To eliminate this error, a 120 Hz signal corresponding to a 60 Hz power line is generated to light the neon lamp.

**Stroboscope Operation (See Fig. 2-5 and Fig. 2-6)**

1. A signal of approximately 7.9 MHz is generated by IC2 and the crystal oscillator, and then divided within IC2. The output signal appearing at terminal No. 1 of IC2 has a frequency of 3840 Hz.

2. This frequency is then fed into IC3 where it is further divided. A 480 Hz signal appears at terminal No. 8, and a 240 Hz signal at terminal No. 11.
3. The 240 Hz signal is divided again into a 120 Hz signal by the flip-flop of IC4.
4. Although stroboscope stripes designed with smaller  $t/T$  ratios appear to be sharper to the eye, they do require stronger illumination than is normally available. The stripes marked on the turntable platter of this equipment have a  $t/T$  ratio corresponding to 13%.

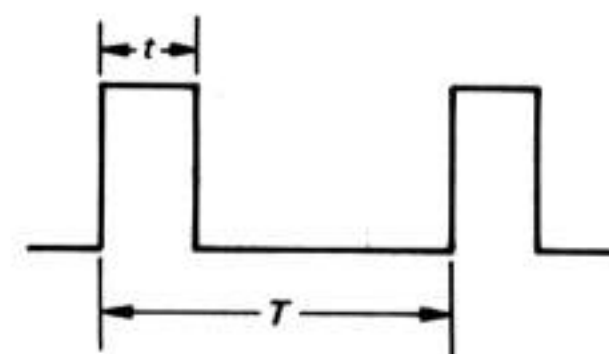

Fig. 2-4.

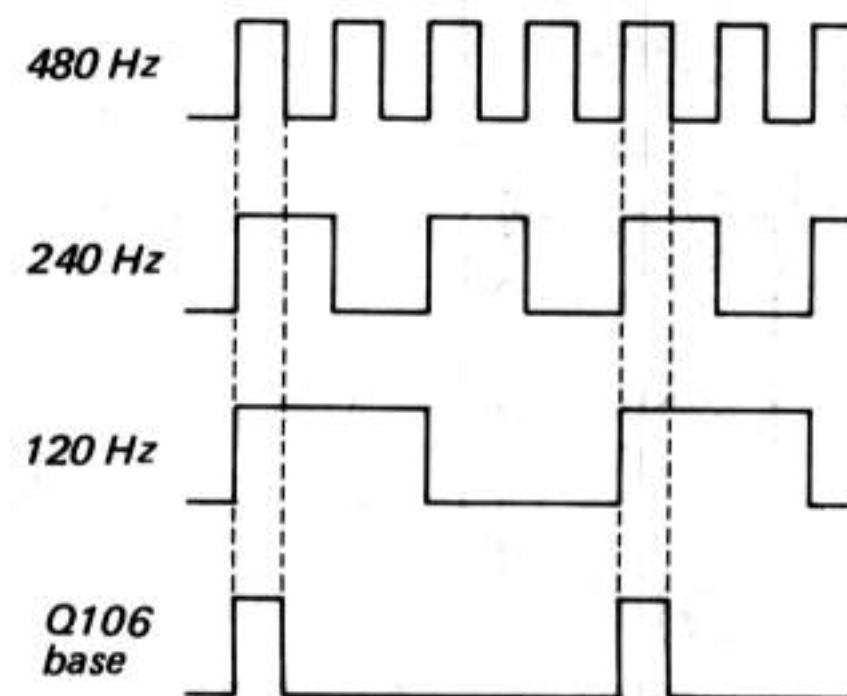

Fig. 2-5.

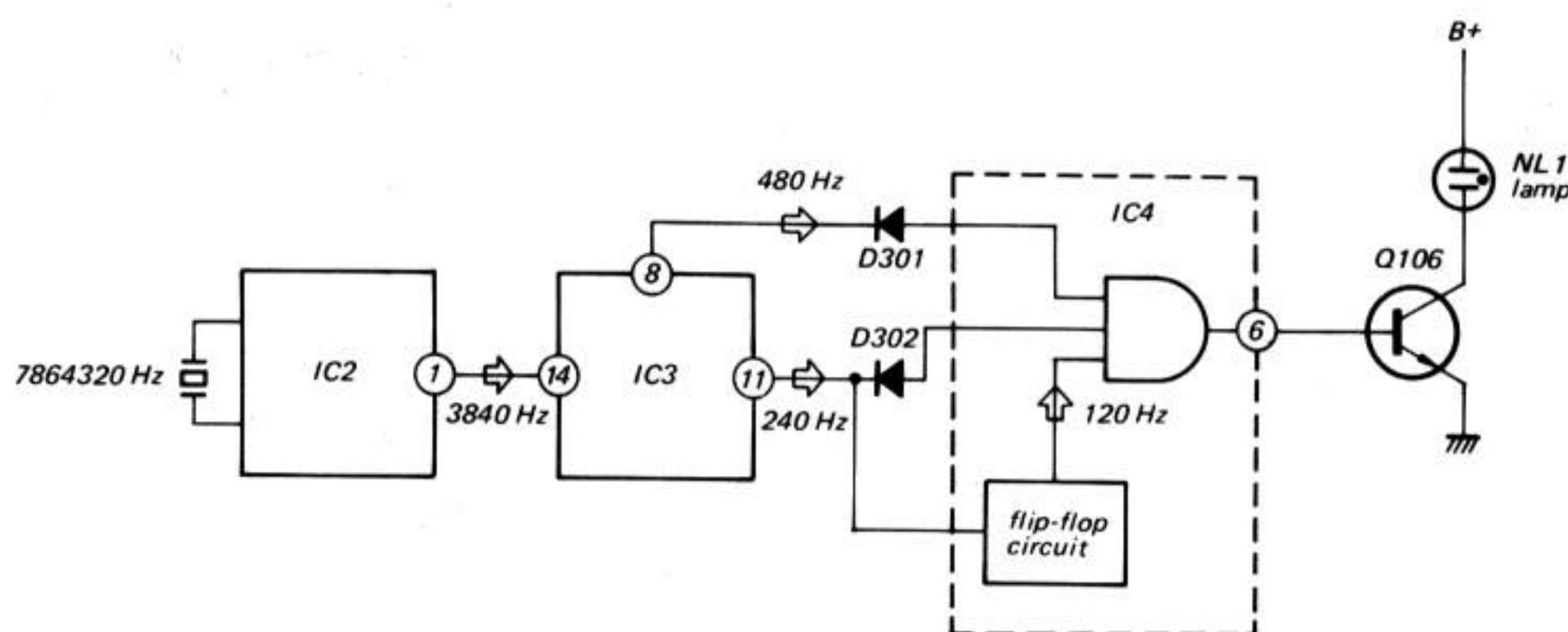

Fig. 2-6.



3. System Control Circuit

The system control circuit is composed of the following four sections:-

1. Flip-flop for start/stop operation (Q408, Q409)
2. Flip-flop for motor operation (Q411, Q412)
3. Flip-flop repeat operation (Q415, Q416)
4. Return-position detector circuit

The control circuit is thus responsible for turning the motor and solenoid (PM) on and off to drive the mechanical system, and activates the automatic lead-in, return, and repeat operations.

3-1. Operation when POWER Switch is turned on. (See Fig. 3-1)

1. When the power switch (S1) is turned on, C409 charges up, and Q410 is turned on (routes ① & ②).
2. Once Q410 is turned on, all three flip-flops are reset by D407, D406, and D409 to the following stable states (routes ③, ④ & ⑤).
  1. Q408 ..... off, Q409 ..... on
  2. Q411 ..... on, Q412 ..... off
  3. Q415 ..... off, Q416 ..... on

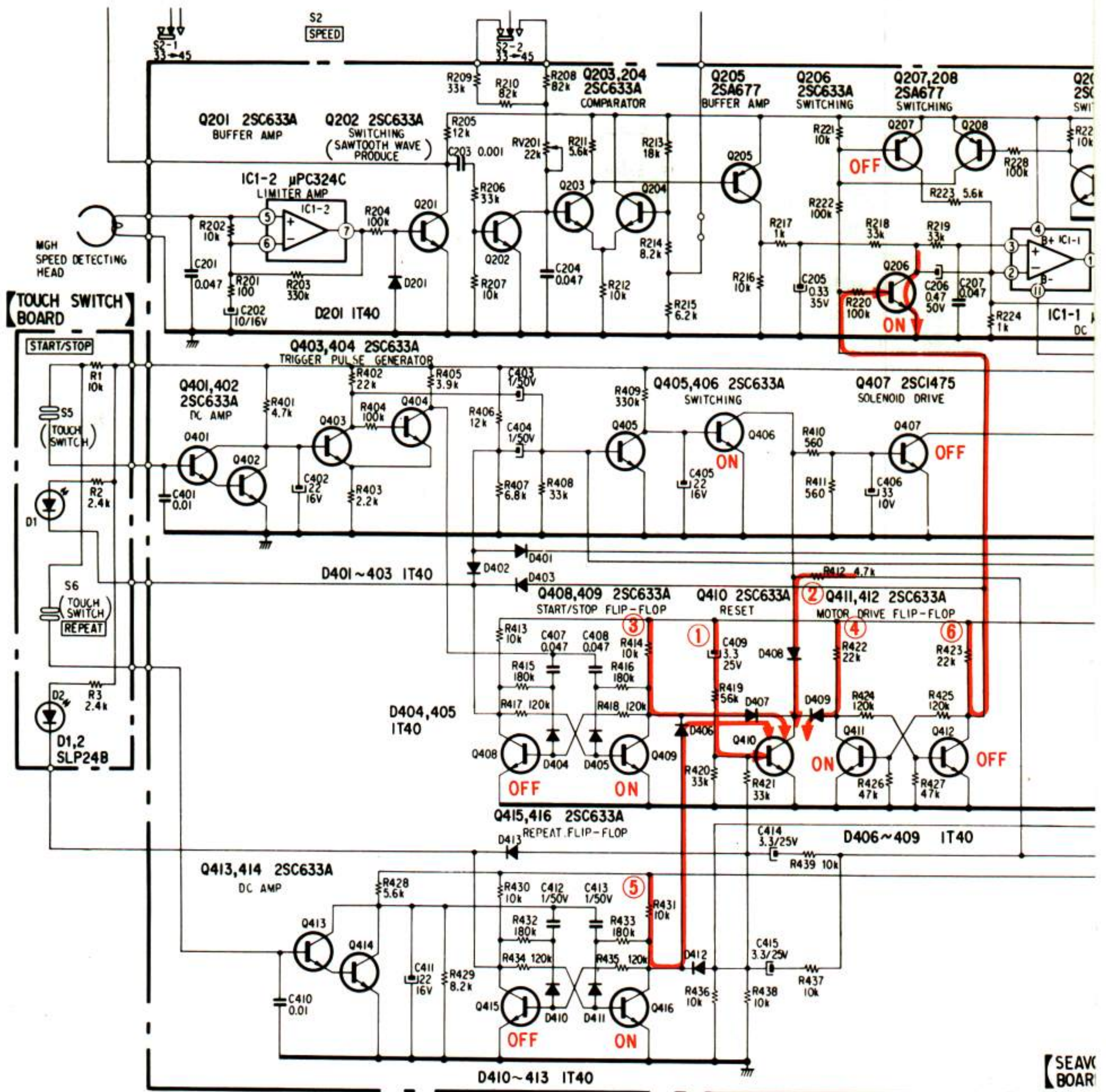
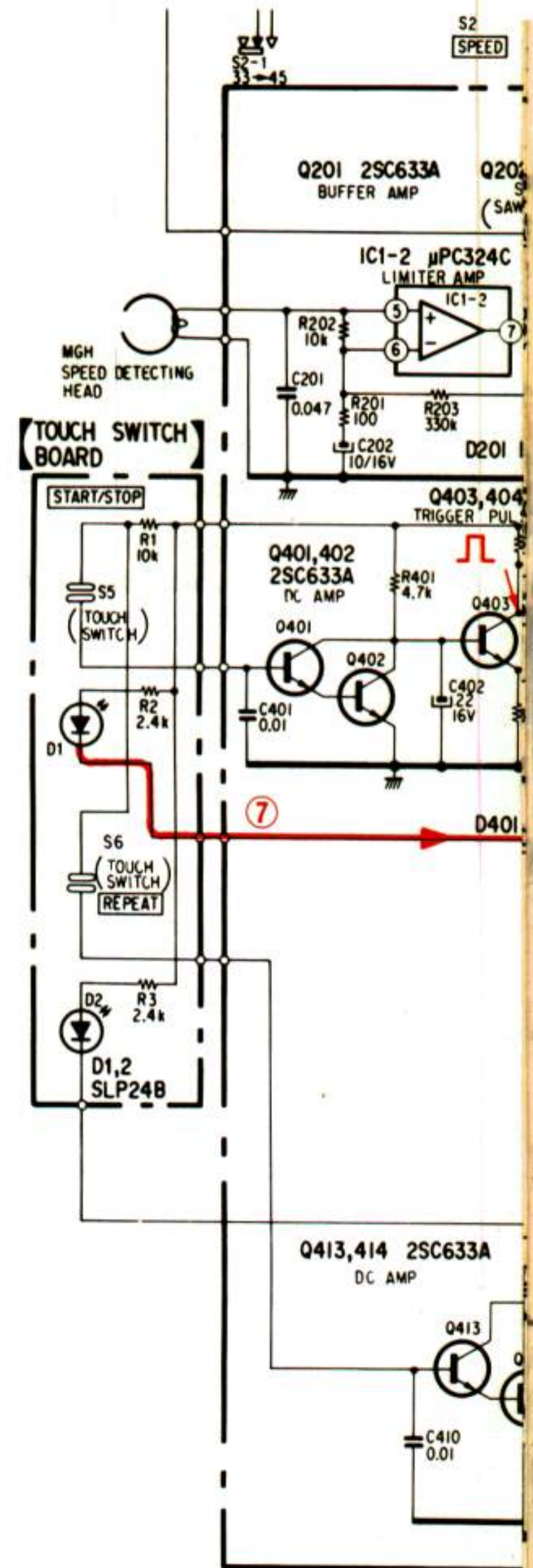
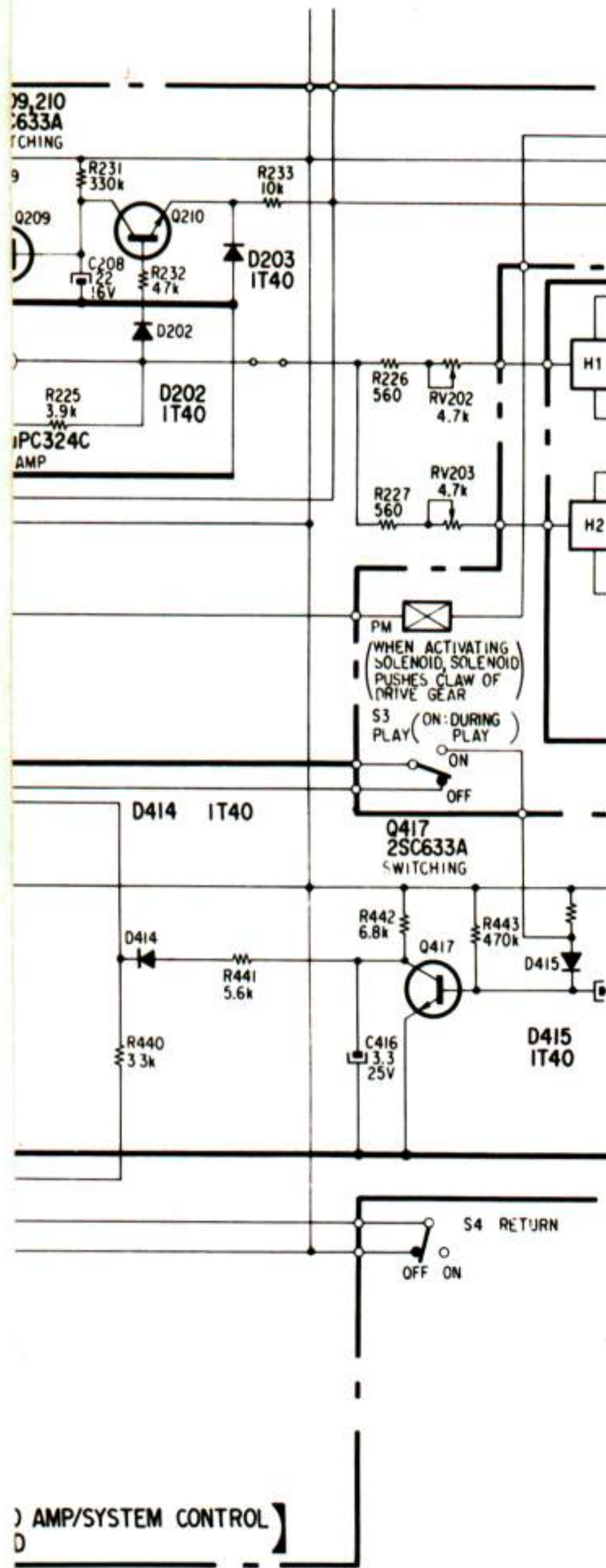

Fig. 3-1.



3. Q206 is turned on, so a voltage is not applied to the ⊕ input terminal of IC1-1 (route ⑥).
4. Q207 is turned off, so a voltage is not applied to the ⊖ input terminal of IC1-1 (route ⑥).
5. IC1-1 does not operate, and the motor does not turn.
6. Since Q406 is turned on (by the charge voltage in C405), Q407 will turn off, thereby preventing the solenoid (PM) from being energized.





3-2. Operation during Auto-start (See Fig. 3-2)

When the START/STOP feather-touch switch (S5) is touched:

1. A negative pulse signal is generated on the collector of Q404 (which forms a Schmitt trigger circuit with Q403). This pulse signal reverses the state of the start/stop flip-flop circuit Q408/Q409, thereby turning Q408 on, and Q409 off.
2. The start indicator (LED) D1 lights up (route 7).
3. Current then flows along route 8, so the collector potential of Q412 inverts the state of the motor flip-flop circuit Q411/Q412. Namely, Q411 turns off, and Q412 on.

4. Consequently, Q206 is turned off, and a voltage is applied to the ⊕ input terminal of IC1-1. And since Q207 is turned on, a voltage is applied to the ⊖ input terminal of this IC.
5. Therefore, IC1-1 operates, starting up the motor.
6. On the other hand, a positive trigger pulse signal is generated on the collector of Q403, and is applied to the base of Q405 to turn Q405 on (route 11).
7. Once Q405 is turned on, C405 is discharged, Q406 is turned off and Q407 turned on. As a result, the solenoid (PM) is energized, thereby activating the mechanical system for automatic lead-in of the tonearm (route 12).

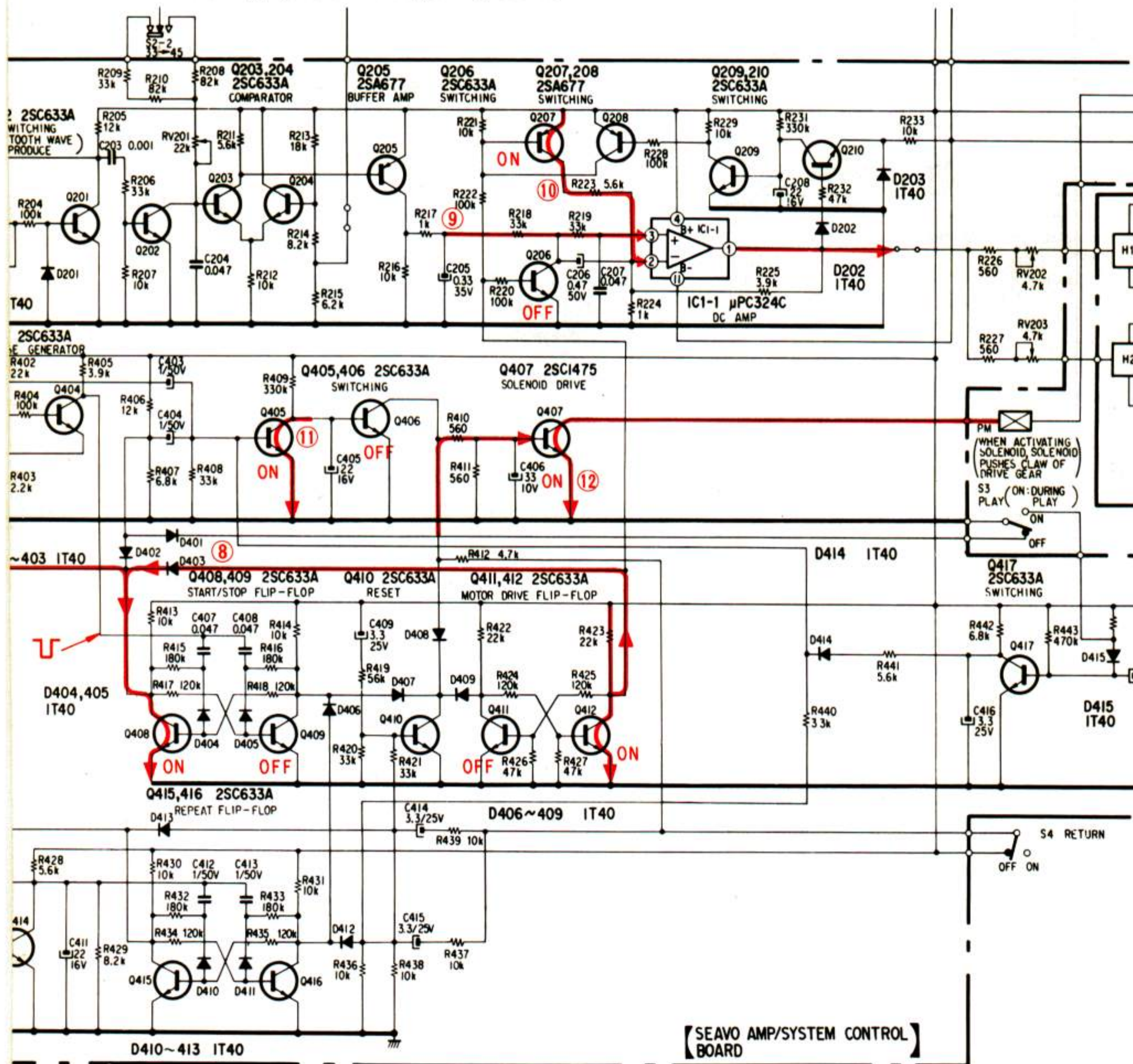

Fig. 3-2.



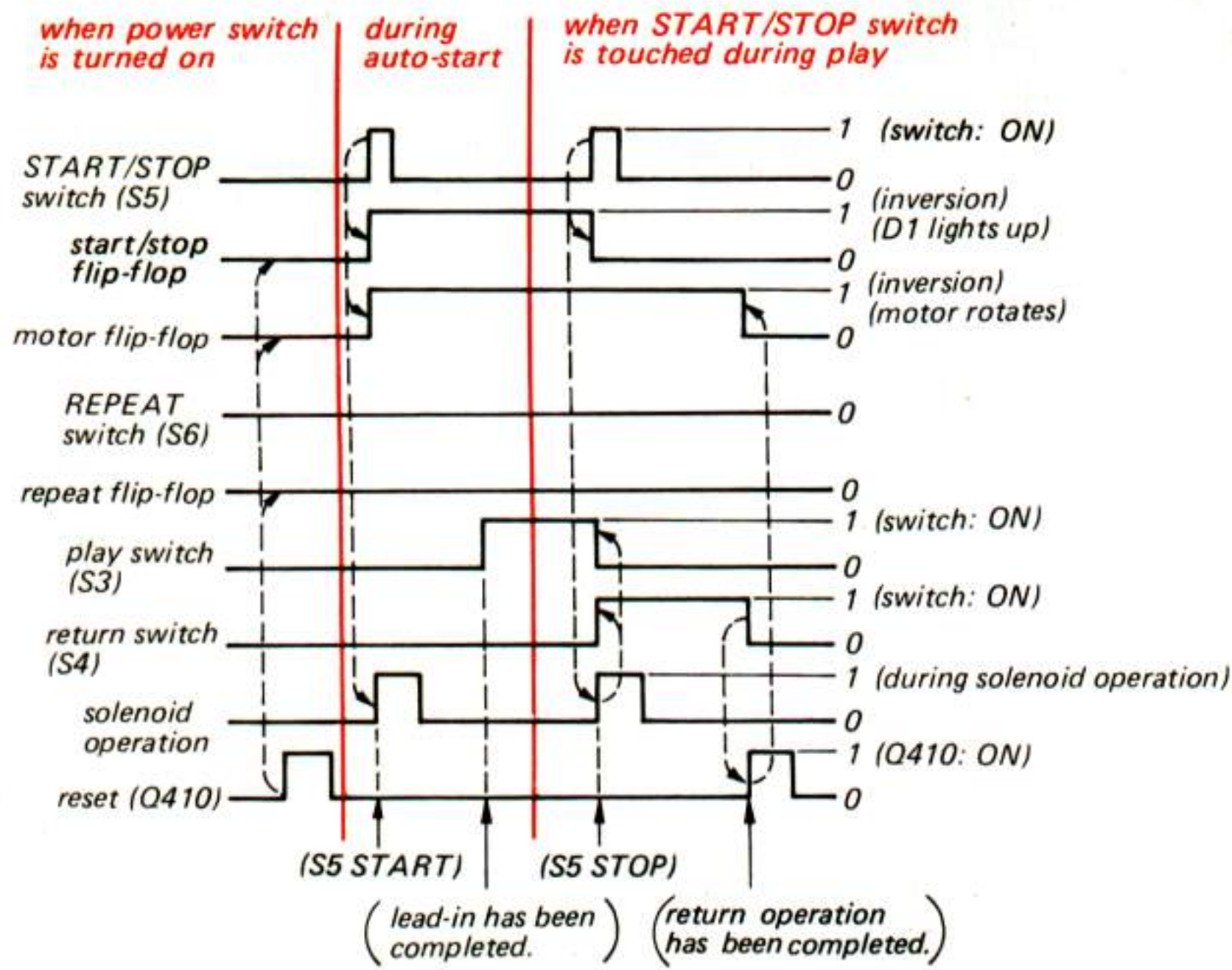
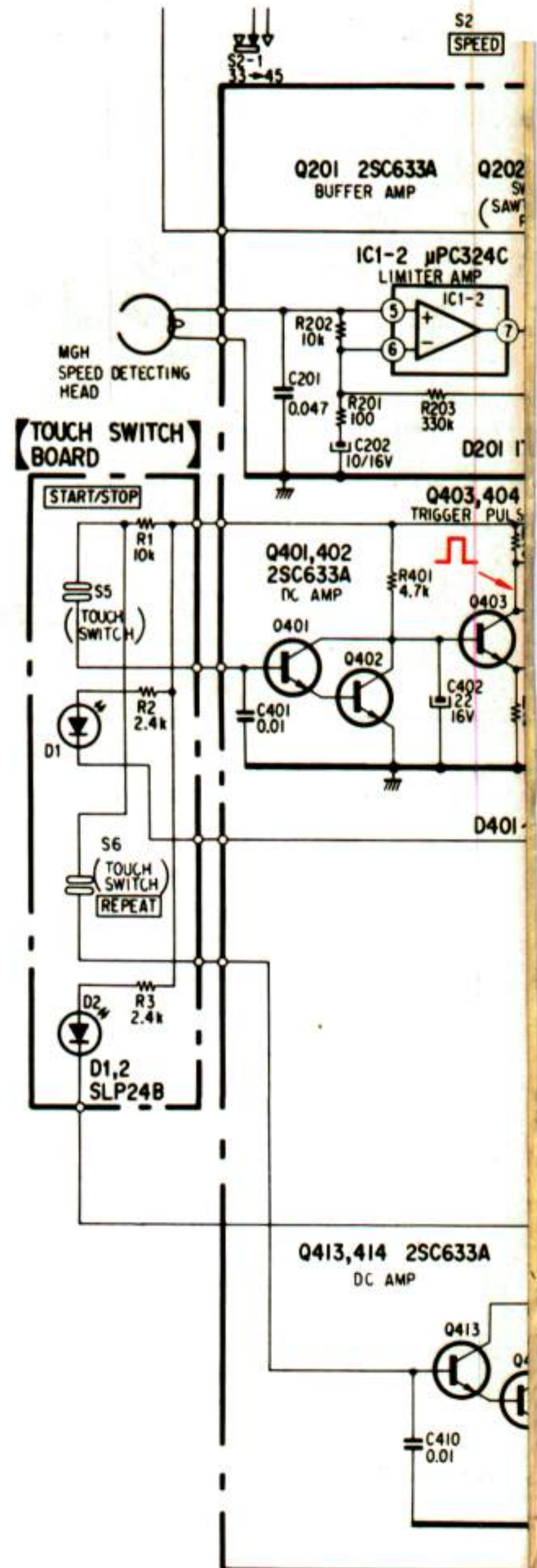

Fig. 3-3.

Fig. 3-1. Operation when the POWER switch is turned on

Fig. 3-2. Operation during auto-start

Fig. 3-3. Operation if START/STOP switch is touched during play





**3-3. Operation if START/STOP Switch (S5) is touched during Play (See Fig. 3-4)**

1. If S5 is touched during play, a negative pulse will be generated on the collector of Q404. This pulse inverts the operation of the Q408/Q409 flip-flop circuit. Namely, Q408 is turned off, and Q409 is turned on.
2. Once Q408 is turned off, the start indicator (LED) D1 is turned off.
3. On the other hand, a positive pulse is generated on the collector of Q403, turning Q407 on, and thereby passing a current through the solenoid (PM). The auto-return mechanism is thus activated, and the tonearm is returned to the arm rest.

4. Due to the operation of the auto-return mechanism, the return switch (S4) is turned on mechanically, thereby discharging C414.
5. When the tonearm returns to the arm rest, this switch again turns off.
6. While C414 is recharging, Q410 is turned on.
7. Consequently, all flip-flops are reset, and the motor stops rotating.
8. The circuitry is thus restored to its original status.

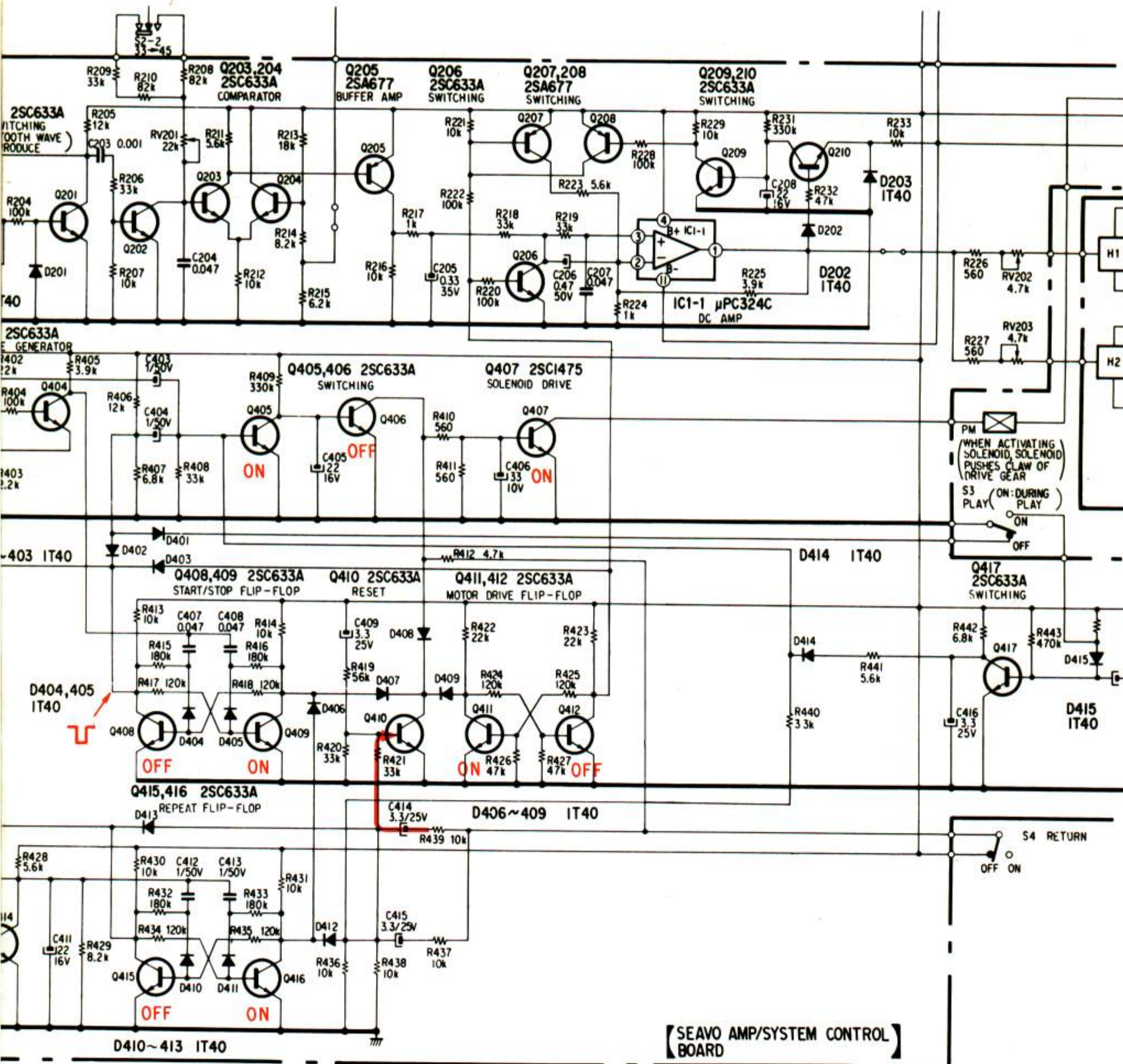

Fig. 3-4.



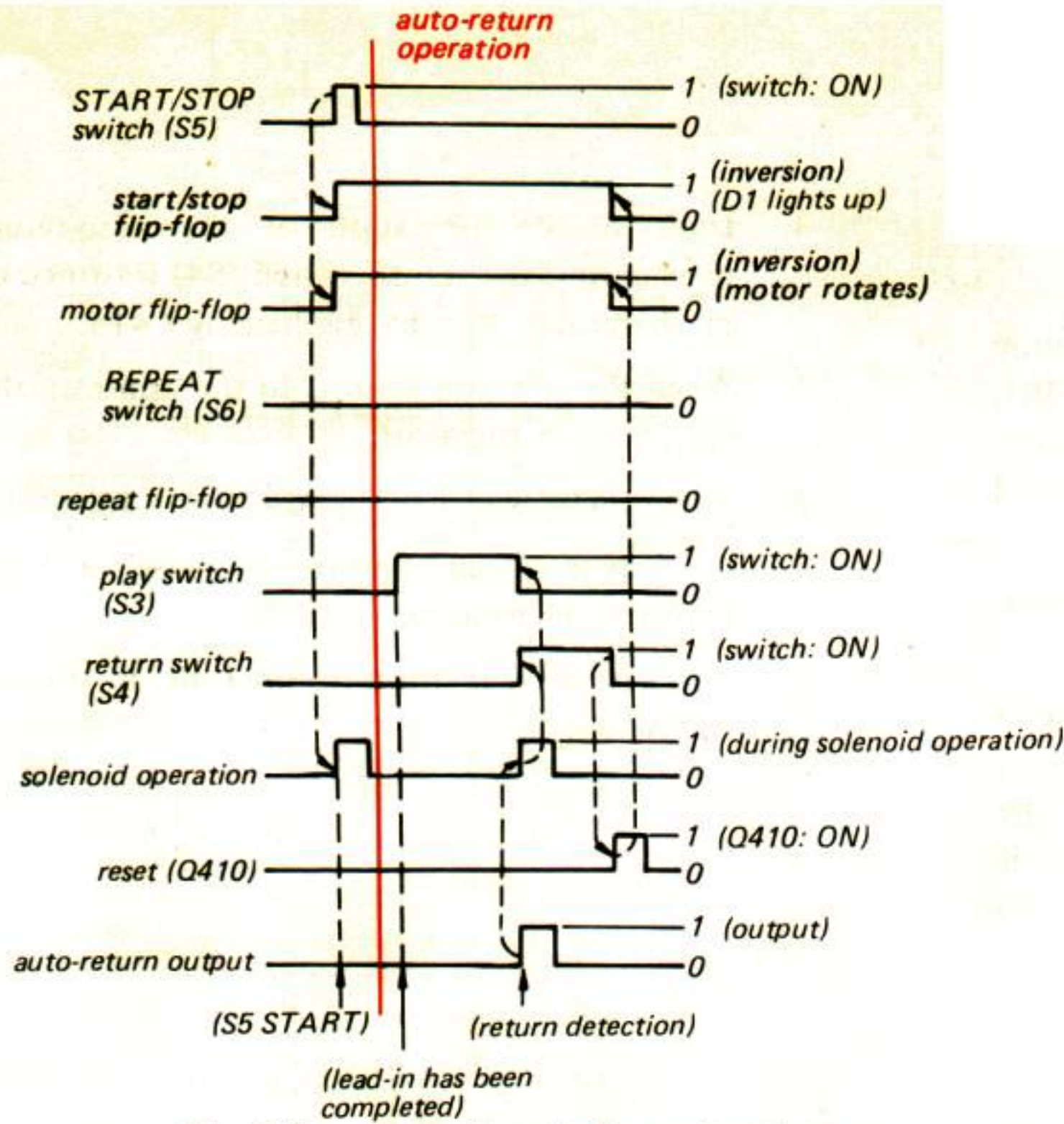

Fig. 3-5. Operation during auto-return

Speed Detection Circuit

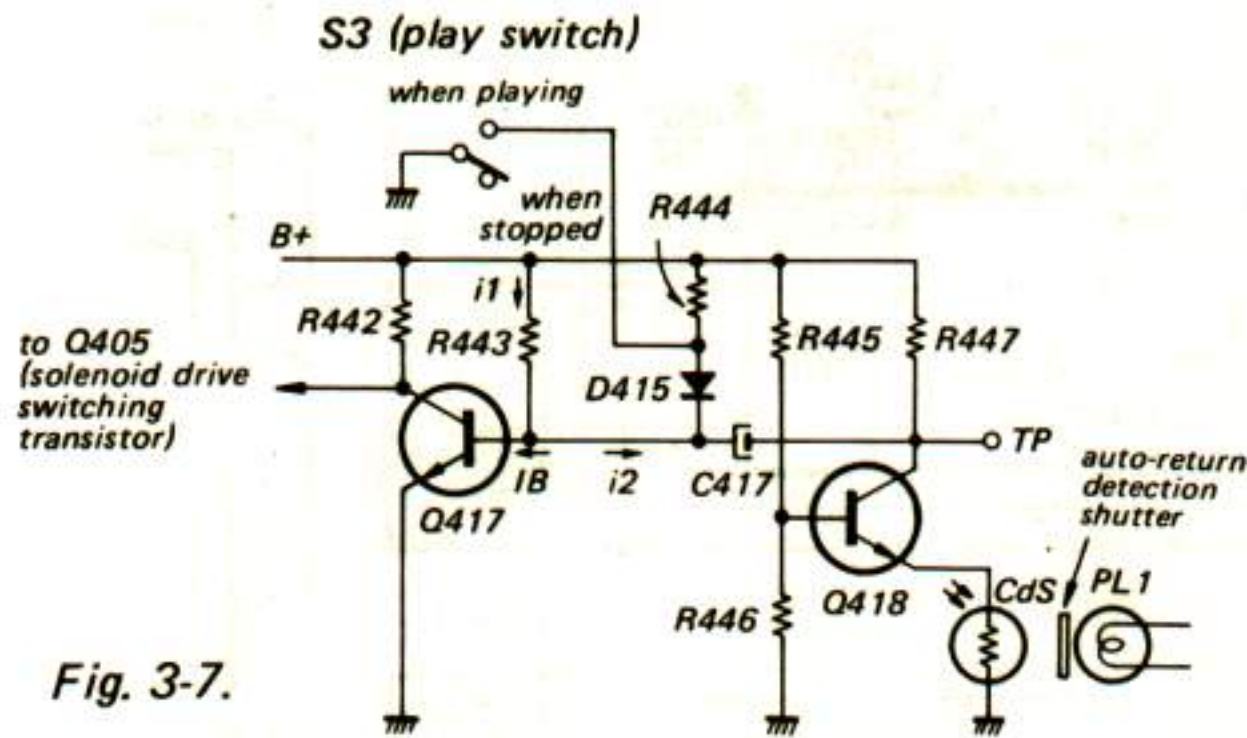

Fig. 3-7.

This circuit, a form of speed detection circuit, is designed to detect sudden changes in  $i_2$  due to the changes in the collector voltage ( $V_{TP}$ ) of Q418.  $i_2$  is given by the following expression:-

$$i_2 = \frac{V_{TP}}{dt} \cdot C417$$

Gradual changes in the position of the detection shutter (due to changes in position of the tonearm as it traces the record groove) result in a change of the amount of light received by the CdS element, thereby reducing its resistance. Then when the amount of change in the detection shutter becomes large,  $i_2$  approaches  $i_1$ , and Q417 is consequently turned off. Therefore, B+ voltage is supplied to the solenoid drive circuit through R442, thereby activating the auto-return mechanism.

In the circuit diagram shown above, D415 and R444 are employed to prevent misoperation when the tonearm is moved rapidly across by hand during the lead-in operation. ( $i_1$  is increased, thereby reducing the sensitivity.)

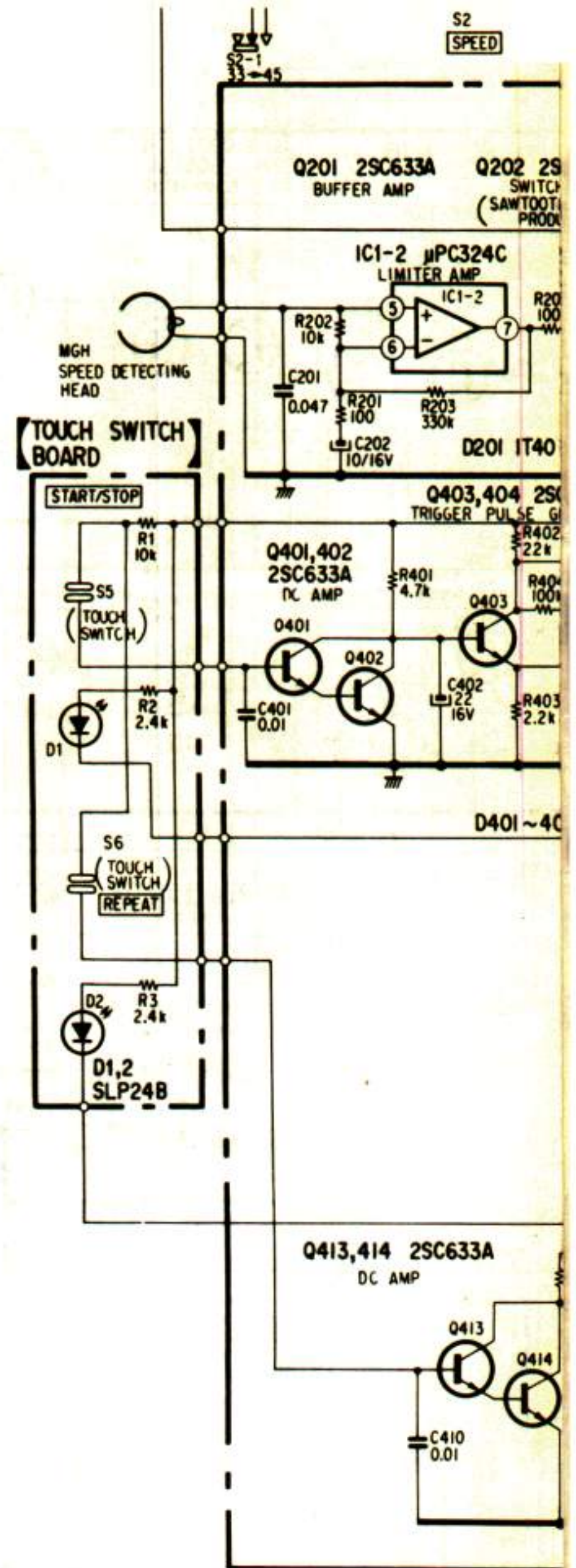



3-4. Operation during Auto-return (See Fig. 3-6)

1. When the power switch (S1) is turned on, Q419, Q420 and Q421 are all turned on. The auto-return operation detector lamp PL1 lights up.
2. The tonearm gradually moves across to, and then enters the auto-return position detection range (within 56.5 mm from the center spindle).
3. Once within the detection range, the pitch of the phonograph record groove changes rapidly (i.e. at the lead-out groove), the speed detection circuit (described later) is activated, turning Q417 off, and Q405 on (route 13).
4. Q407 is also consequently turned on, passing a current through to the solenoid (PM) (route 14).

5. Activation of the solenoid (PM) operates the auto-return mechanism, thereby bringing the tonearm back to rest automatically.
6. When operating the auto-return mechanism, the return switch (S4) is turned on mechanically, and C414 discharges.
7. Once the tonearm returns to the arm rest, this return switch is turned off again.
8. While C414 is recharging, Q410 is turned on (route 15).
9. As a result, all flip-flops are reset, the start indicator (LED) D1 turns off, and the motor stops rotating.
10. The circuitry is thus restored to the original status.

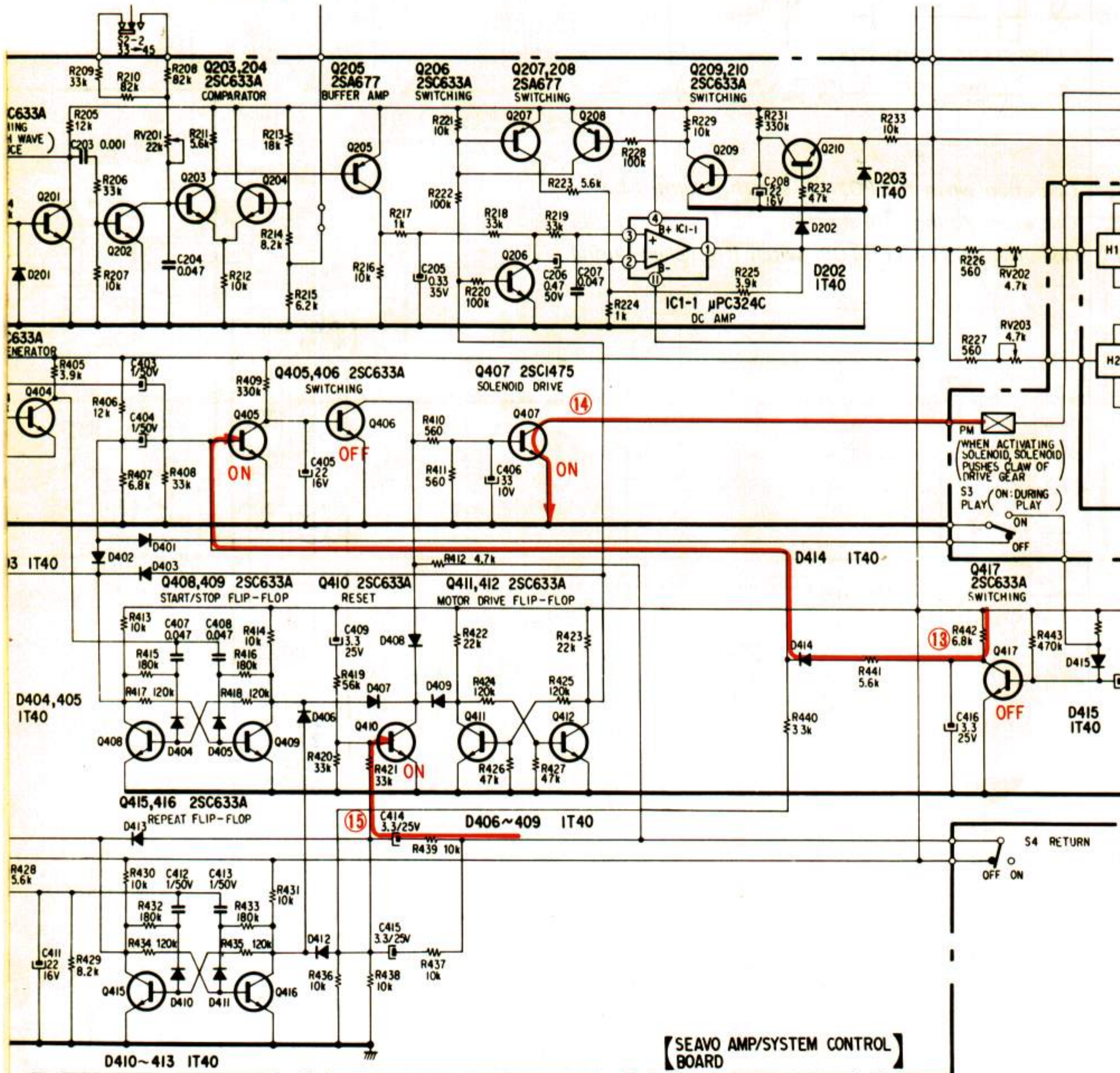

Fig. 3-6.



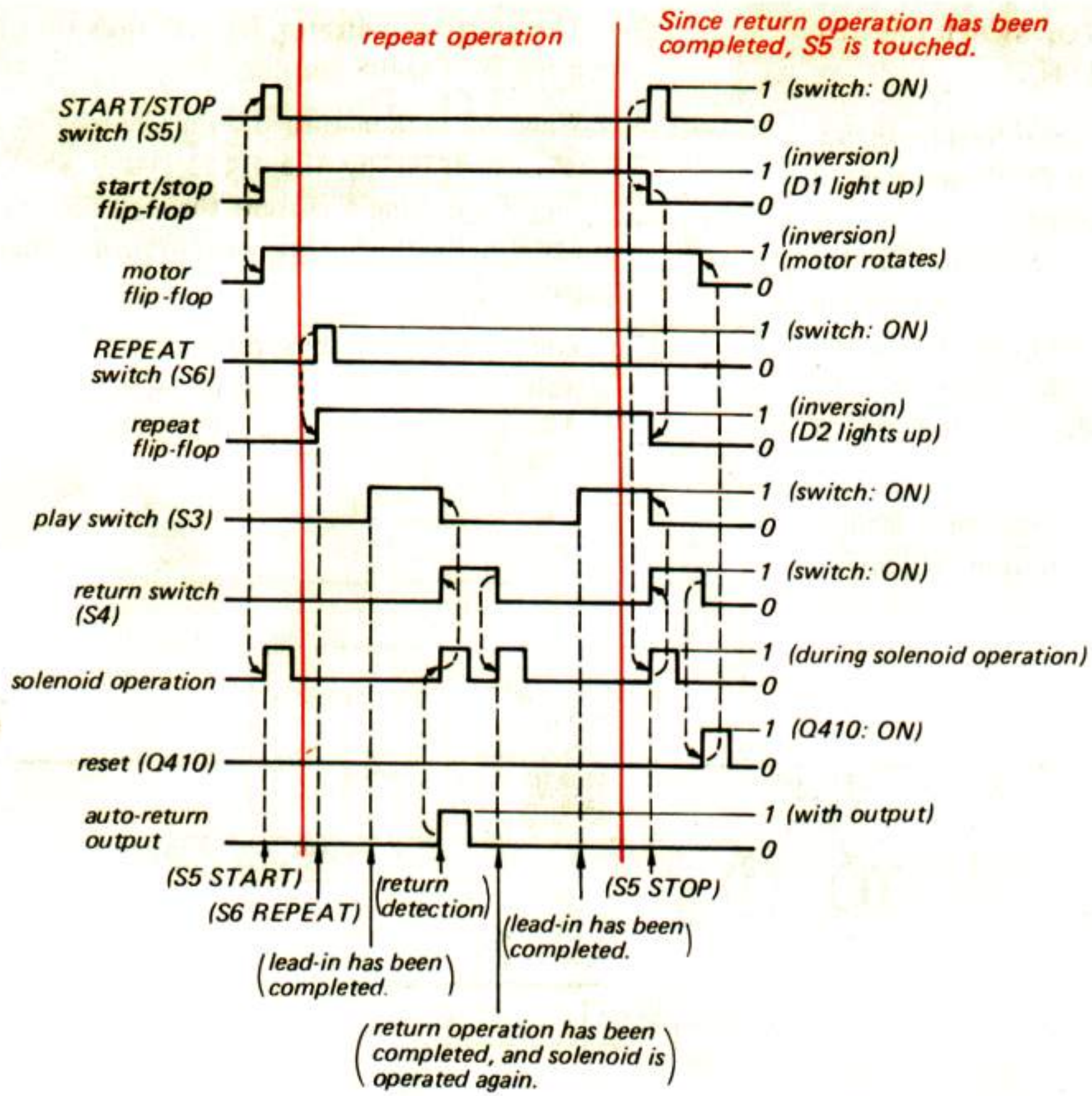
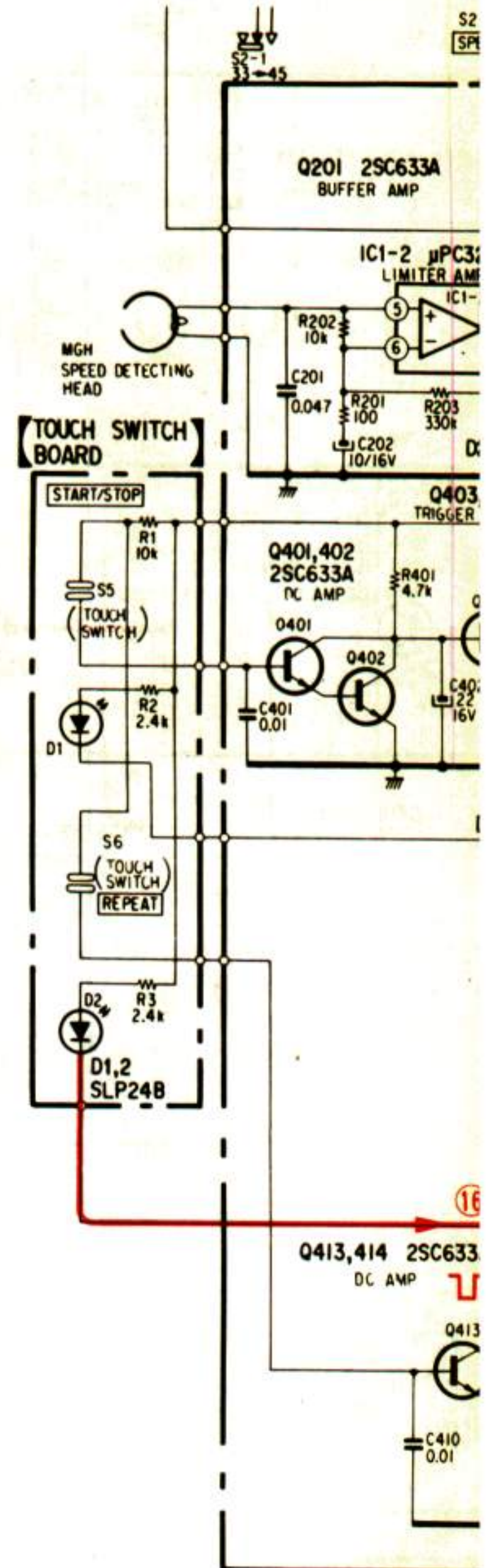

Fig. 3-8. Repeat operation





3-5. Repeat Operation (See Fig. 3-9)

When the feather-touch repeat switch (S6) is touched during play, the repeat indicator (LED) D2 lights up, and the same record is played over and over again.

1. When S6 is touched, a negative pulse is generated on the collector of Q414. This pulse inverts the state of the repeat flip-flop circuit, Q415/Q416. That is, Q416 is turned off, and Q415 is turned on.

When Q415 is turned on, the repeat indicator D2 lights up (route 16).

2. When the tonearm reaches the return position, the auto-return mechanism is activated, and the return switch (S4) turned on mechanically.

The tonearm then returns to the arm rest, and S4 then turns off again. But since Q415 is on in this case, D413 is biased in the forward direction. Therefore, unlike the operation for auto-return, Q410 is not turned on (route 17).

3. Consequently, neither the start/stop flip-flop circuit, Q408/Q409 nor the motor flip-flop Q411/Q412 circuits are inverted in this case.
4. Q405 is thus forward biased (i.e. turned on) by the charged voltage in C415 (route 18).
5. As a result, a current flows through the solenoid (PM), the lead-in mechanism is activated, and the tonearm is again moved across for the start of play.

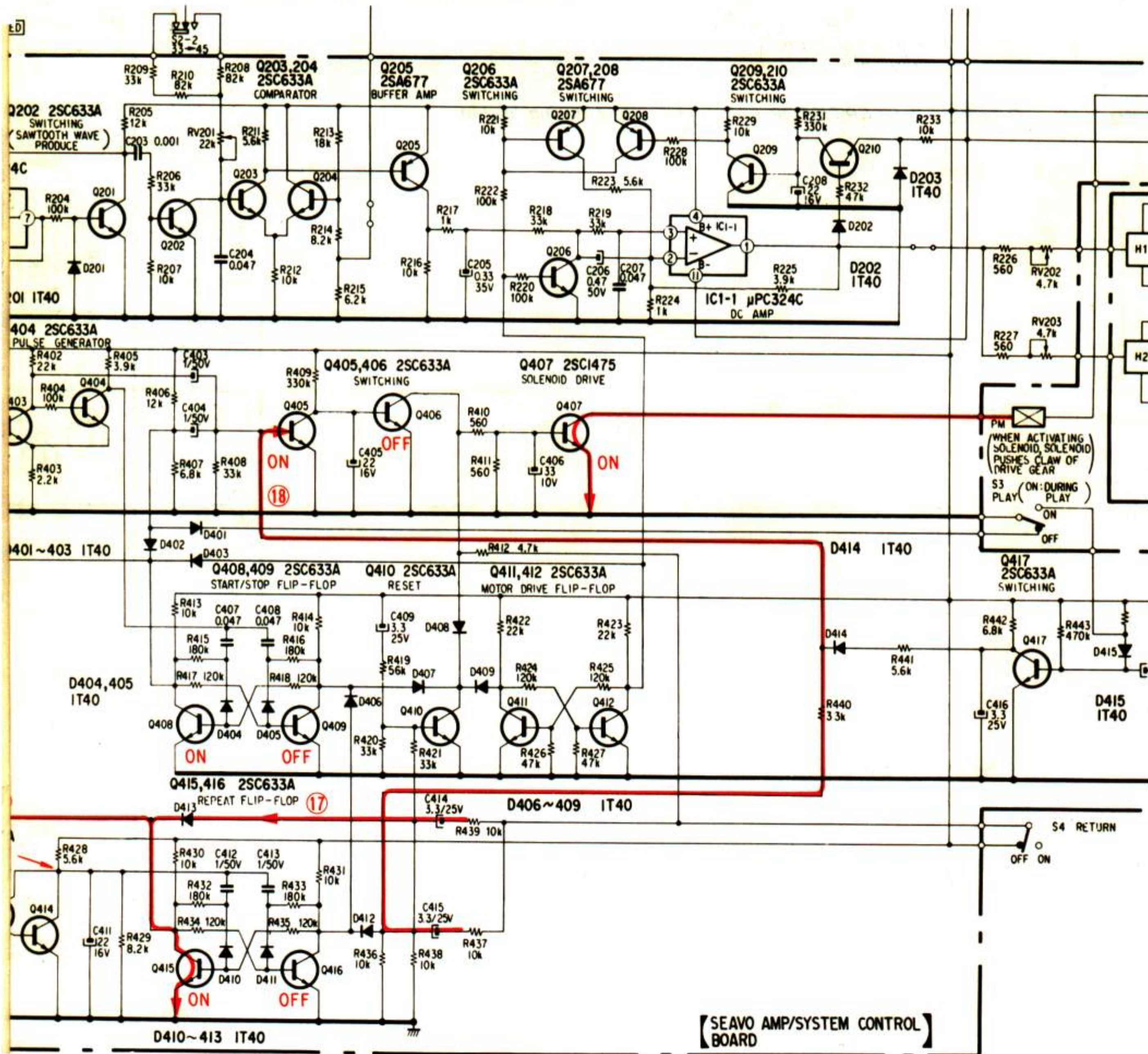

Fig. 3-9.



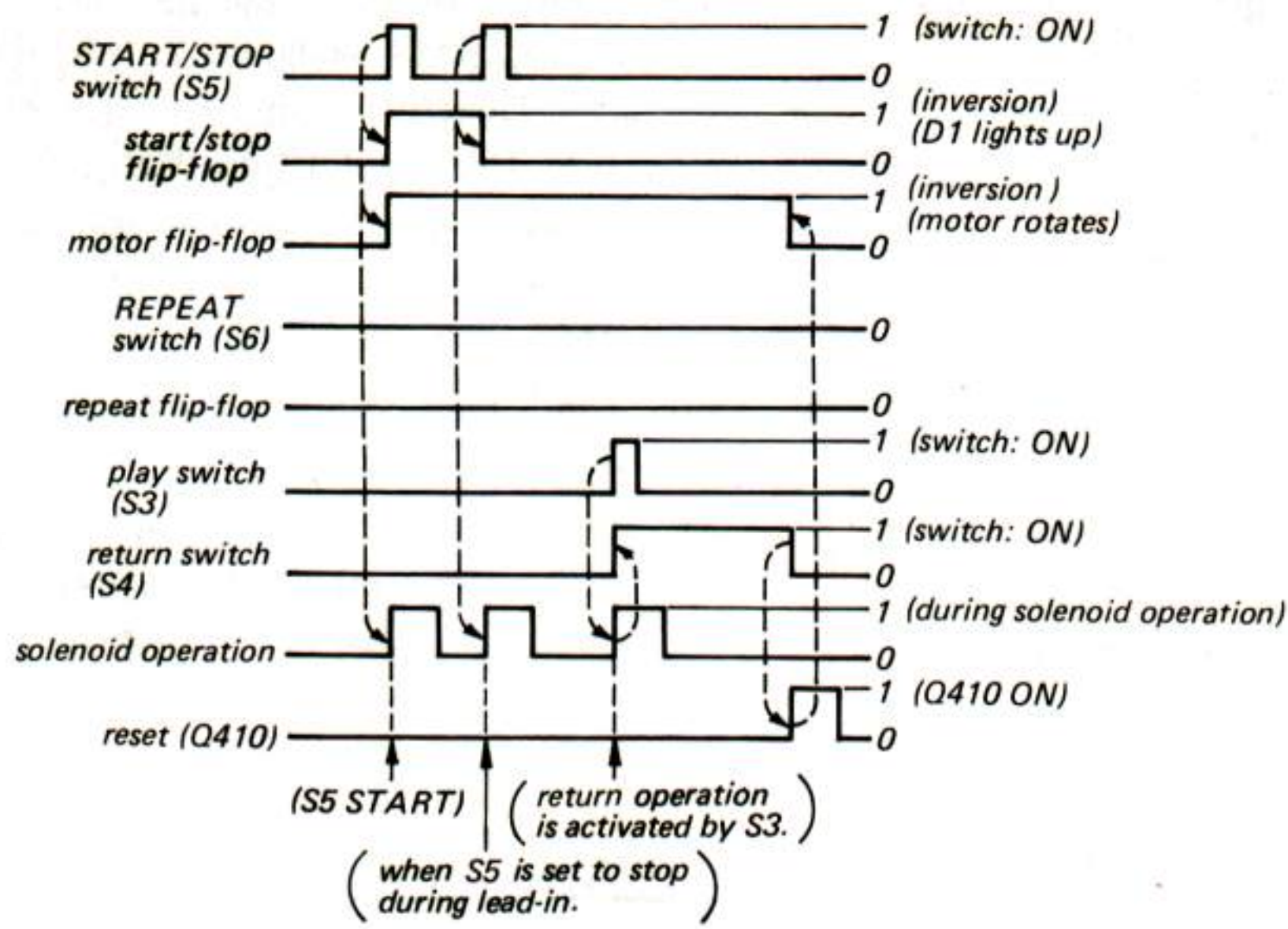
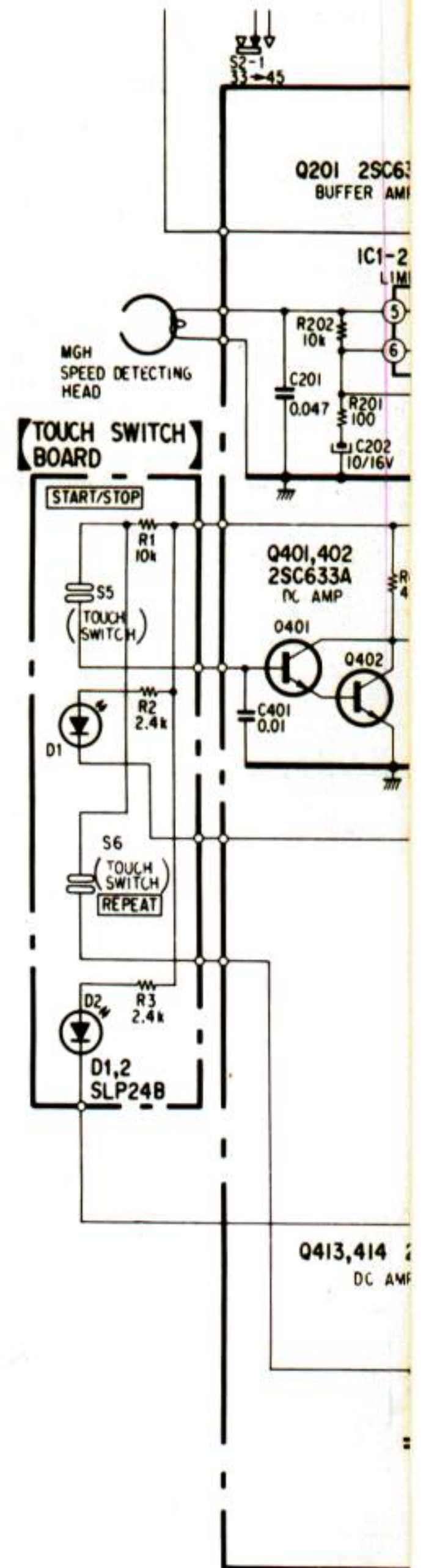

Fig. 3-10. Operation if START/STOP switch is touched during lead-in





3-6. Operation if the START/STOP Switch touched during Lead-in (See Fig. 3-11)

1. At the commencement of the auto-start operation, Q408 of the start/stop flip-flop circuit is turned on, and Q409 turned off. Since Q408 is turned on, the start indicator D1 is turned on. Q411 of the motor flip-flop circuit is turned off, and Q412 is turned on, thereby starting up the motor. Activation of the mechanical systems results in lead-in motion of the tonearm.
2. If S5 is then touched during this lead-in operation, the start/stop flip-flop circuit is inverted. That is, Q408 is turned off, and Q409 is turned on.

3. The starting indicator D1 will thus turn off as a result of Q408 turning off.
4. When S3 is then turned on mechanically, Q405 is turned on by the D402/D402 AND gate, thereby passing a current through the solenoid, and activating the auto-return operation (route 21).
5. The circuitry is thus restored to the original status.

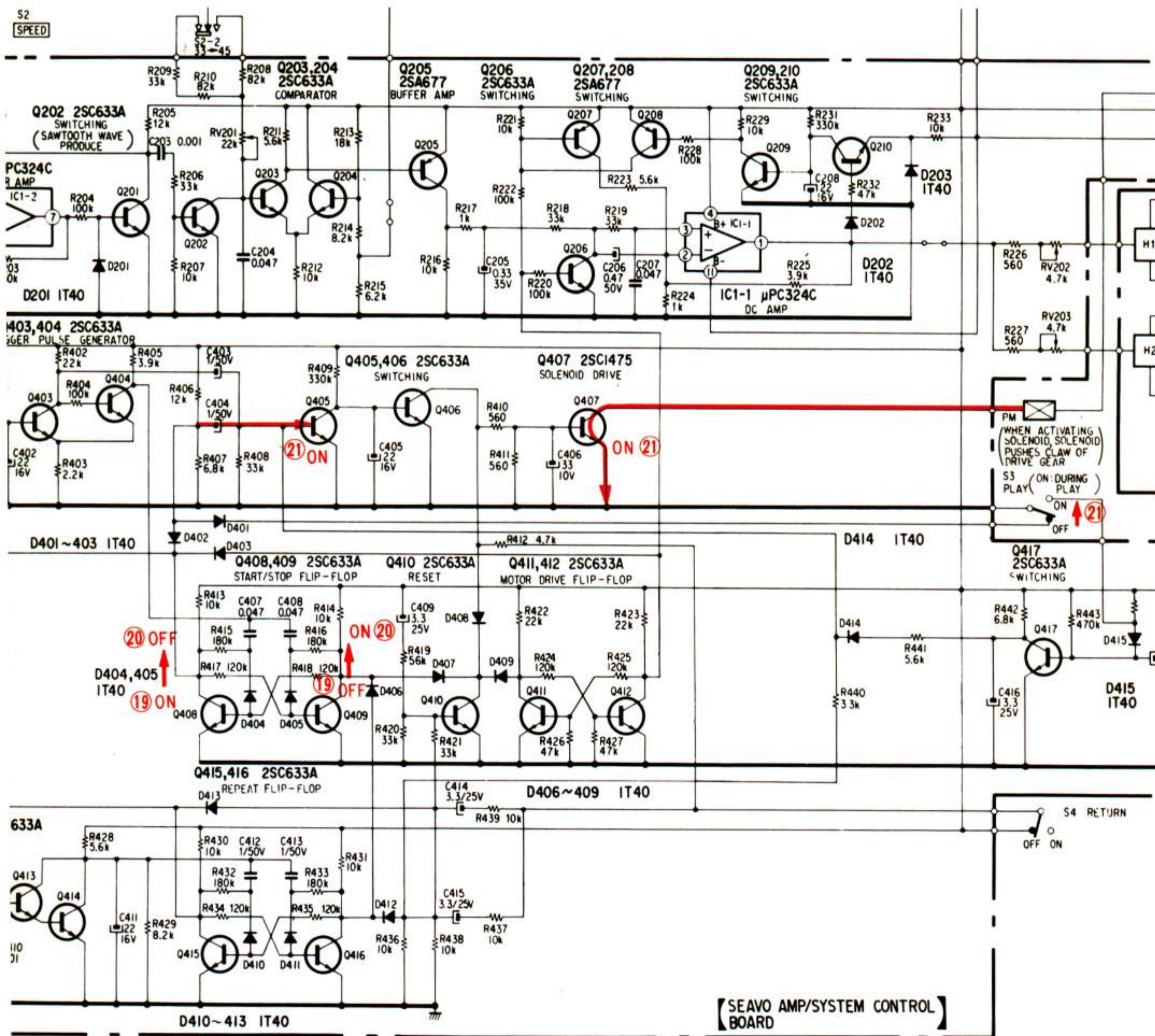

Fig. 3-11.



**4. Hall Motor**

The PS-X6/X7 is equipped with the newly developed BSL (brush and slotless) dc servo motor, which has the following major advantages.—

1. Extremely uniform torque.
2. All-electronic switching (no mechanical contacts used at all), resulting in very little noise.
3. Extremely stable performance, and long operational life.

**Magnetic Pole Arrangement (See Fig. 4-1)**

- The motor coils L1 and L2 (plus L3 and L4) form a pair, connected in series.
- The reason for positioning two Hall elements H1 and H2 at an angle of  $22^{\circ}30'$  from each other is to displace the electrical phase angle by  $90^{\circ}$ , thereby rotating the rotor in a 2-phase action.
- For the same reason, the positions of the coil pairs are set at an angle of  $67^{\circ}30'$ .
- The coil windings are wound in a partial cone shape to match the similarly shaped magnets, 8 of which are arranged in a circle underneath the rotor.

**Motor Internal View (top view)**

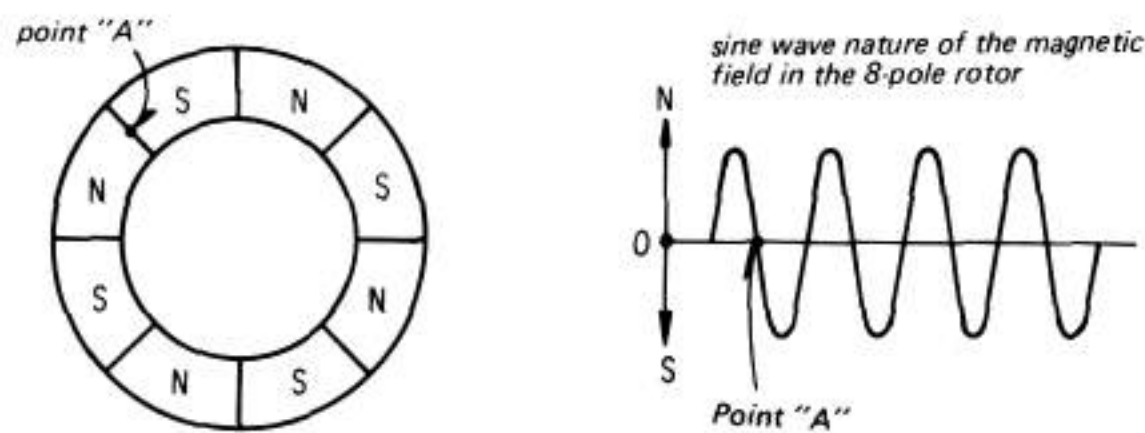
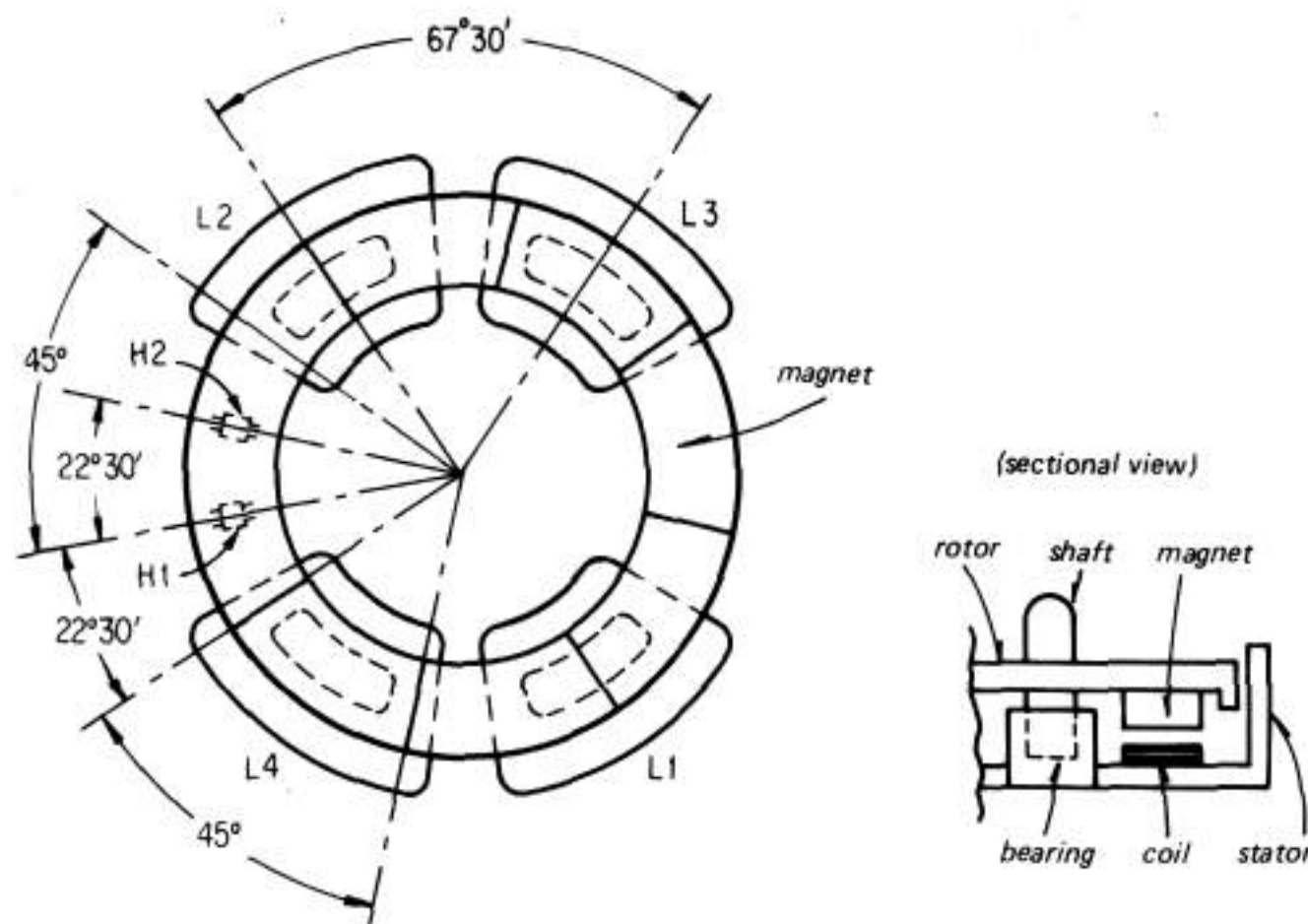
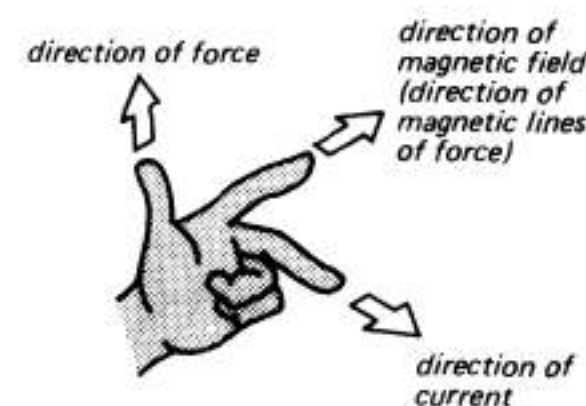

Fig. 4-1.

- Hall elements and motor coils have been set apart at an angle of  $22^{\circ}30'$  so that the peak of an N or S pole magnetic field will cut across the center of a motor coil at the same time that the magnetic field peak of the preceding or following S or N pole cuts across a Hall element.

**Generation of Rotational Force (See Fig. 4-2)**

According to Fleming's left hand rule, the force generated in the motor coils will be in the counter-clockwise direction, but since the coils are fixed, the magnets (attached to the rotor) will rotate in the clockwise direction. (Refer to Figs. 3-3 and 3-4.)



Fleming's left hand rule

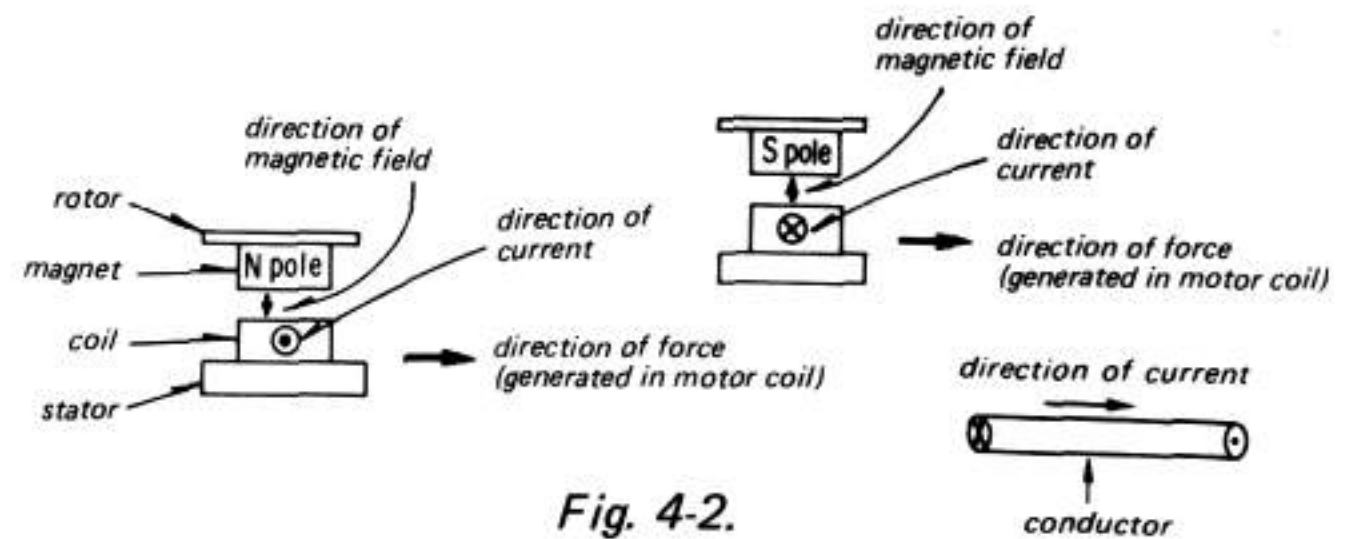

Fig. 4-2.

When an N pole corresponds to the Hall element H1 (shown in the Fig. 4-3), a positive voltage is generated in H1. This voltage is then amplified by IC1-4, and applied to Q211.

When Q211 is turned on, B+ voltage is applied to L1 and L2. The current flowing through L1 and L2, and the magnetic field produce an electro-magnetic force which spins the rotor in the direction of the arrow as shown in Fig. 4-3.

When an N pole corresponds to the Hall element H2 as shown in Fig. 4-3, current flows through L3 and L4, thereby generating the same electro-magnetic force to continue spinning the rotor.

When an S pole corresponds to the Hall element H1 (shown in Fig. 4-4), a negative voltage is generated in H1. This voltage is then amplified by IC1-4, and applied to Q212.

When Q212 is turned on, B- voltage is applied to L1 and L2. The current flowing through L1 and L2, and the magnetic field produce an electro-magnetic force which spins the rotor in the direction of the arrow as shown in Fig. 4-4.



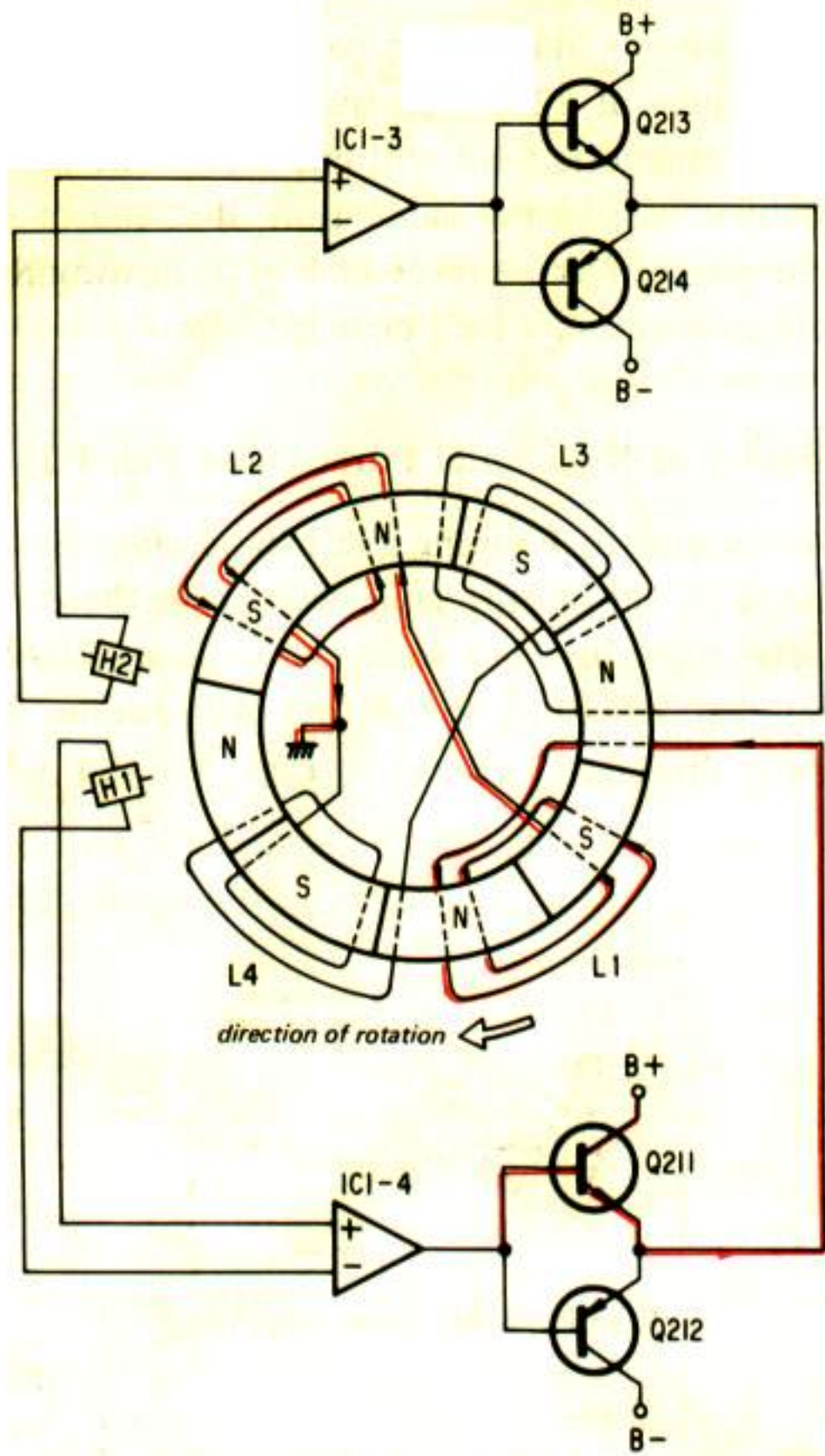

Fig. 4-3.

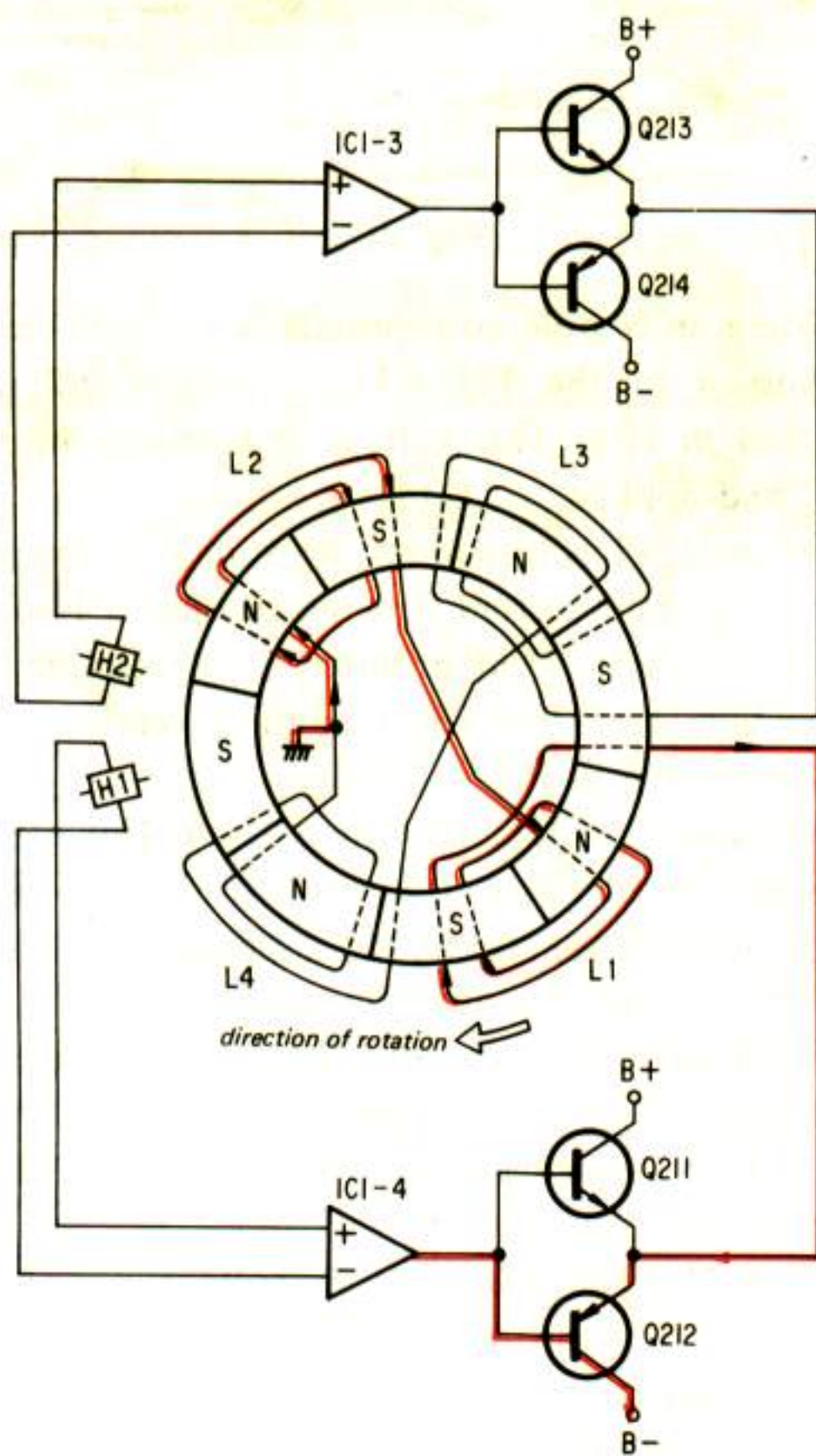

Fig. 4-4.

When an S pole corresponds to the Hall element H2, current flows through L3 and L4, thereby generating the same electro-magnetic force to continue spinning the rotor.

Hence, N and S poles are repeatedly positioned oppositely to the Hall elements H1 and H2 every  $22^{\circ}30'$  of a rotation thereby generating the voltages in these elements, resulting in the production of a current in the motor coils, and subsequent rotation of the motor.

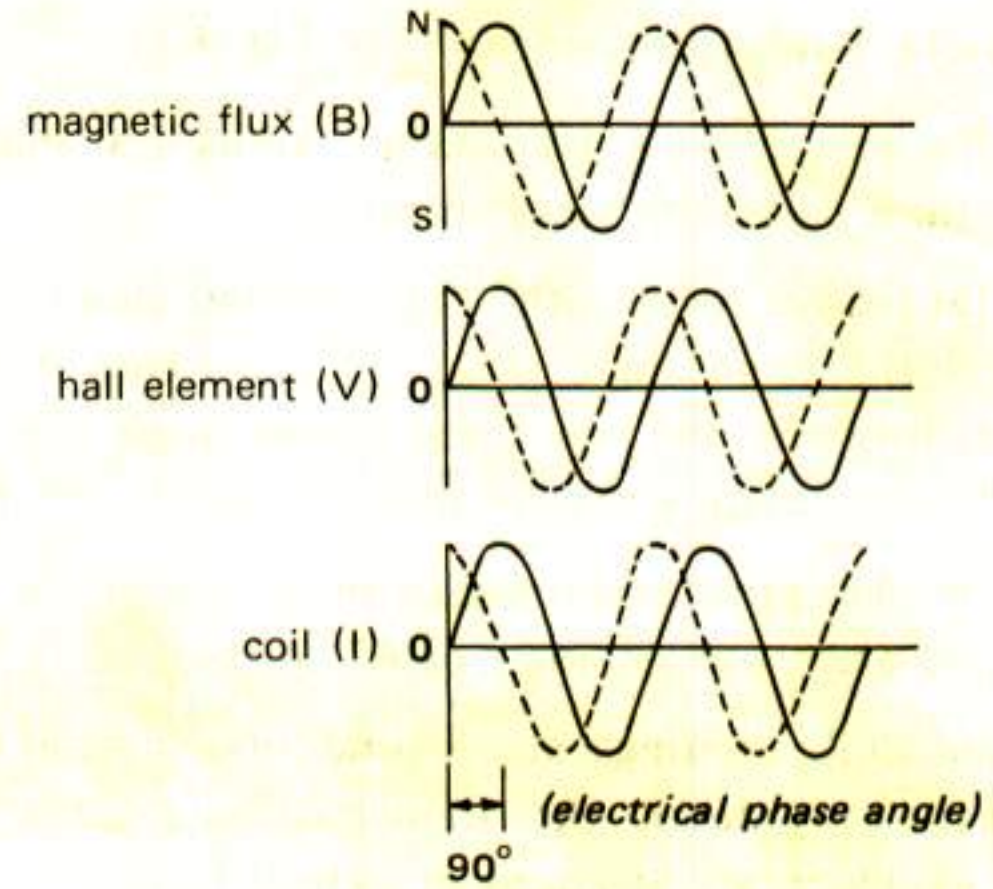

Fig. 4-5.

**Rotational Force**

The rotational force (torque  $F$ ) varies directly with the strength of the magnetic field ( $B$ ) cutting across the coils, and the amount of current ( $I$ ) flowing through the coils.

That is,  $F = B \cdot I$

But since the magnetic field produced by the magnets of the rotor varies in accordance with a sine wave relation with the angle of rotation, and the pairs of motor coils are arranged  $90^{\circ}$  out of phase each other, the combined torque will be constant.

**Constant Speed Rotation (See Figs. 4-6 and 4-7)**

In order to maintain constant turntable speed, this model features a magnetic-disc detection system in the speed-detector stage, and a crystal oscillator in the phase control stage of a crystal-locked servo system.

Changes in rotational speed of the turntable are detected by the speed-detection head fixed on the frame. (S and N magnets are mounted around the outer rim of the turntable platter with a very high degree of precision.) The reference standard frequencies detected by this head are 284 Hz at 33 rpm, and 384 Hz at 45 rpm. Any changes in frequency detected by this head are converted into voltage signals, and fed to the servo amplifier.



In addition, the phase of the frequency signal from the speed detection head is compared with the reference phase of the crystal oscillator frequency. Any difference in phase is also converted into a voltage signal, and fed to the servo amplifier, thereby ensuring accurate turntable rotational speed.

Since motor speed is determined by the amount of current flowing through the motor (that is, through the motor coils), motor speed may be conveniently changed by simply changing the flow of current through the Hall elements. In other words, if motor speed tends to deviate from the reference standard value due to external influences, the constant speed value may be maintained by simply varying the amount of current flowing through the Hall elements in proportion to the amount of deviation in turntable speed.

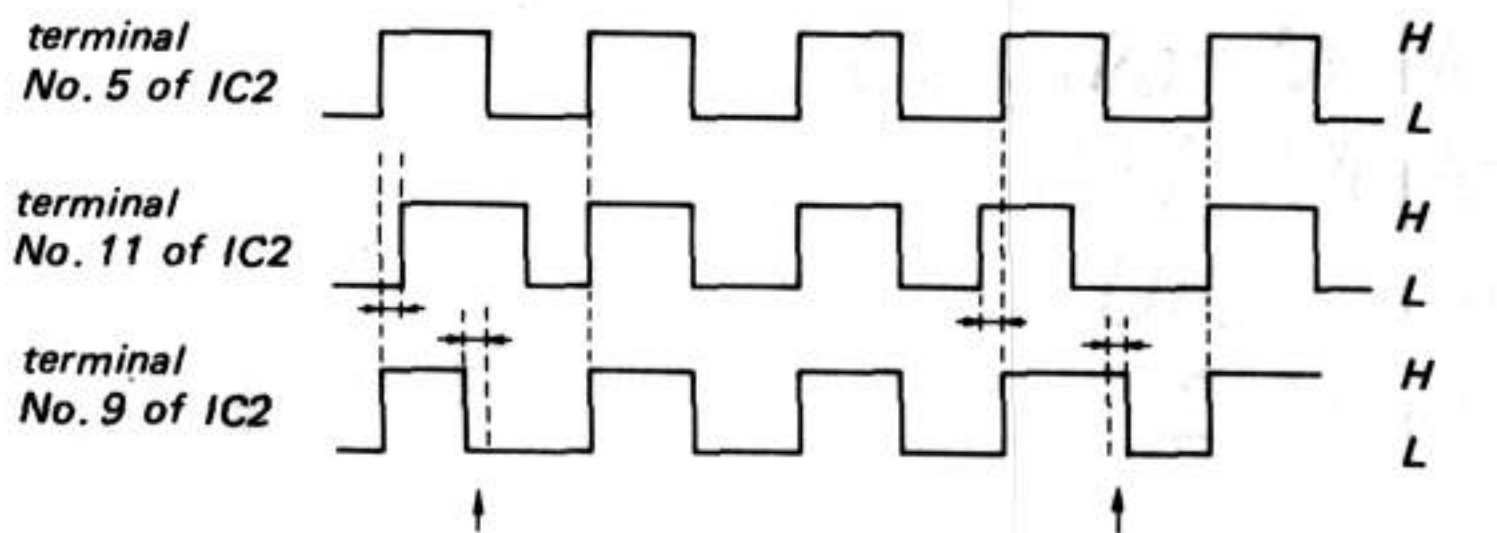

When rotational speed slows down, the output is lowered only for the portion of change. When rotational speed increases, the output is raised only for the portion of change.

Fig. 4-7.

Phase Control

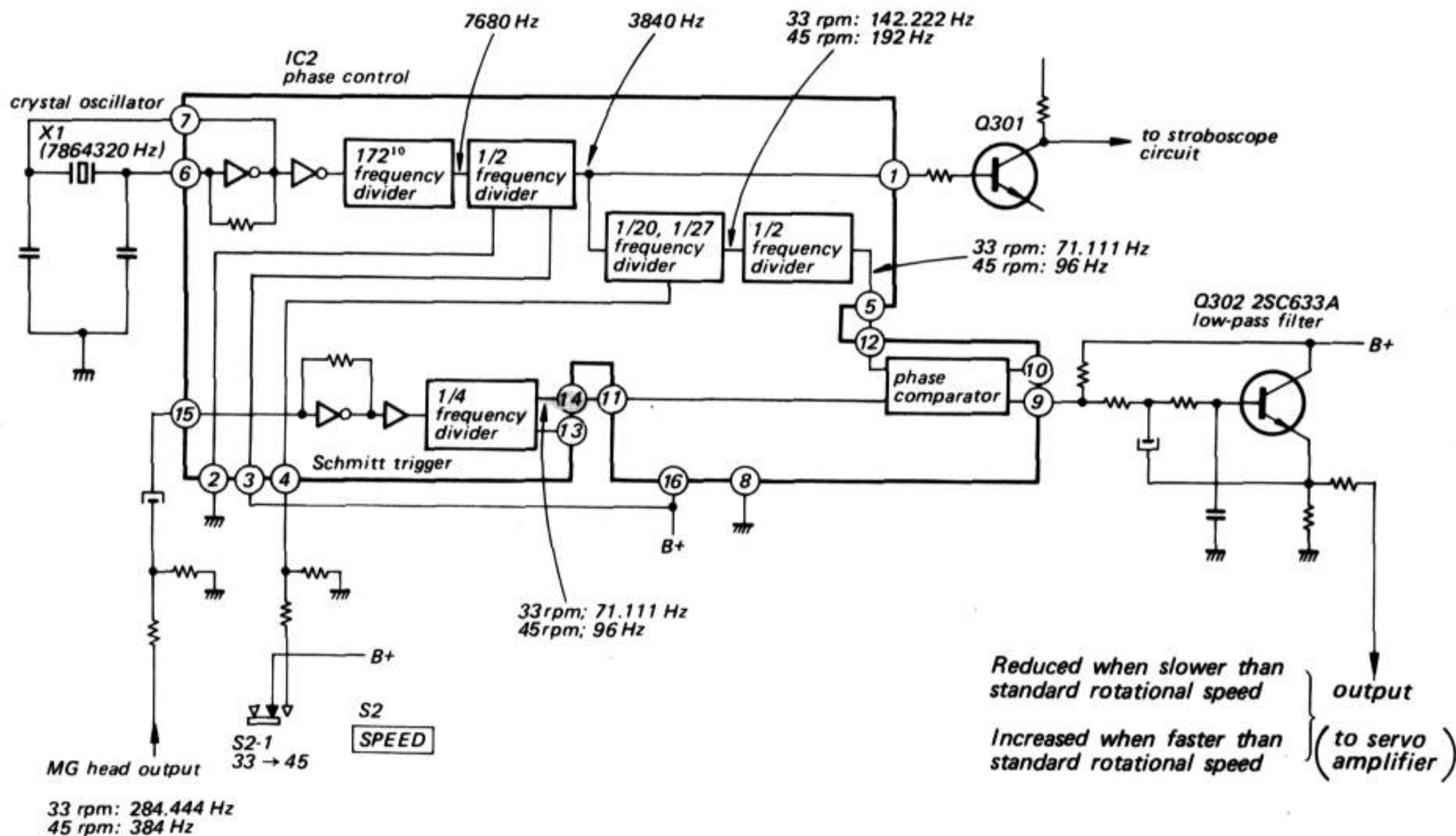

Reduced when slower than standard rotational speed } output  
 Increased when faster than standard rotational speed } (to servo amplifier)

Fig. 4-6.



**Sony Corporation**

© 1978

— 20 —