

GX-77

STEREO TAPE DECK

- Notes:**
- * This manual is applicable to both silver and black panel models.
 - * Supply reel and tape shown in photograph not included in standard accessories.
- Remarques:**
- * Ce manuel s'applique aussi aux modèles avec panneaux argent et noir.
 - * La bande et la bobine sur la photo ne sont pas comprises dans les accessoires standards.
- Opmerkingen:**
- * Deze gebruiksaanwijzing is van toepassing op modellen met zilver en zwart paneel.
 - * De afgebeelde aanvoerspel met tape behoort niet tot het standaardtoebehooren.
- Anmärkningar:**
- * Bruksanvisningen gäller både för modellerna med silverpanel och modellerna med mattsvart panel.
 - * Matarspölen och bandet på bilden tillhör inte standard tillbehören.
- Anmerkungen:**
- * Diese Betriebsanleitung gilt auch für die Ausführung mattsilber und mattschwarz.
 - * Die auf dem Foto abgebildete Ablaufbandspule und das Band sind im Standardzubehör nicht enthalten.
- Notas:**
- * Este manual cubre ambos modelos, el de panel plateado y el de panel negro.
 - * El carrete de suministro y la cinta mostrados en la fotografía no están incluidos como accesorios estándar.

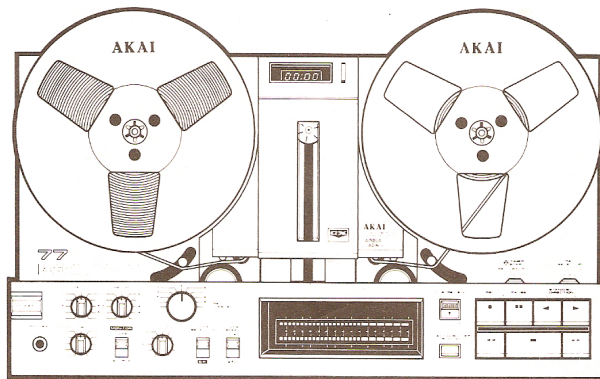

WARNING

To prevent fire or shock hazard, do not expose this appliance to rain or moisture.

Operator's Manual	Page 1-20
Manuel de l'utilisateur	Page 21-39
Gebruiksaanwijzing	Biz. 40-58
Bruksanvisning	Sid 59-77
Bedienungsanleitung	Seite 78-96
Manual del usuario	Pagina 97-115

AKAI

Operator's Manual

WARNING

POWER REQUIREMENTS

Power requirements for electrical equipments differ from area to area.

Please make sure that your equipment meets the power requirements in your area.

120 V, 60 Hz for USA and Canada

220 V, 50 Hz for Europe except UK

240 V, 50 Hz in UK and Australia

110V, 120V, 220V or 240V, 50 or 60 Hz for other countries.

If in doubt, ask a qualified electrician.

VOLTAGE CONVERSION

Do not attempt this conversion yourself.

Models for Canada, USA, Europe, UK and Australia are not equipped with this facility.

Each unit is preset at the factory depending on its destination, but some units can be converted to 110V, 120V, 220V or 240V as required. If your unit has this feature, take the equipment and the following voltage conversion to a qualified Service Repair Shop or a professional serviceman.

1. Disconnect the Power Cord.
2. Loosen the holding screws and feet with a screwdriver and remove the back panel.
3. Remove the Voltage Selector plug and reinsert so that the proper area voltage shows through the plug cut-out.

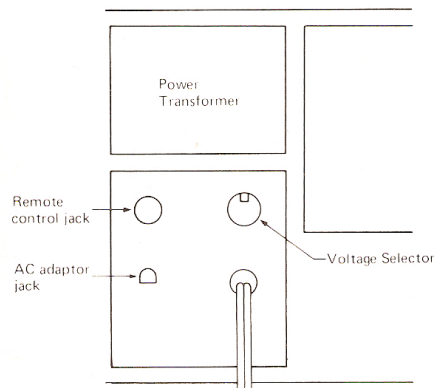

This equipment confirms to No. 76/889/EEC standard.



CAUTION

RISK OF ELECTRIC SHOCK
DO NOT OPEN



**CAUTION: TO REDUCE THE RISK OF ELECTRIC SHOCK, DO NOT REMOVE COVER (OR BACK).
NO USER-SERVICEABLE PARTS INSIDE.
REFER SERVICING TO QUALIFIED SERVICE PERSONNEL.**



The lightning flash with arrowhead symbol superimposed across a graphical representation of a person, within an equilateral triangle, is intended to alert the user of the presence of uninsulated "dangerous voltage" within the product's enclosure that may be of sufficient magnitude to constitute a risk of electric shock to persons.



The exclamation point within an equilateral triangle is intended to alert the user of the presence of important operating and maintenance (servicing) instructions in the literature accompanying the appliance.

PRECAUTIONS

1. Use only household AC power sources. Never use DC power sources.
2. Touching the plug with wet hands risks dangerous electric shocks. Always pull out by the plug and never the cord.
3. Make sure the power consumption of each audio component does not exceed wattage specified on the rear panel. Only connect other audio components.
4. Only let a qualified professional repair or reassemble the equipment. An unauthorized person might touch the internal parts and receive a serious electric shock.
5. Never allow a child to put anything, especially metal into this equipment. A serious shock or malfunction may occur.
6. If water is spilled on this equipment, disconnect and call your dealer.
7. Make sure the equipment is well ventilated and away from direct sunlight.
8. Keep away from heat (stoves, etc.) to avoid damage to the external surface and internal circuits.
9. Avoid spray-type insecticides which will damage the equipment and may ignite suddenly.
10. To avoid damaging the finish never use alcohol, paint thinner or other similar chemicals.
11. Always place the equipment on a flat and solid surface.
12. Please read this manual in its entirety and keep it handy for further reference.

**CONTROLS
COMMANDES
BEDIENINGSORGANEN**

**MANÖVERORGAN
BEDIENUNGSELEMENTE
CONTROLES**

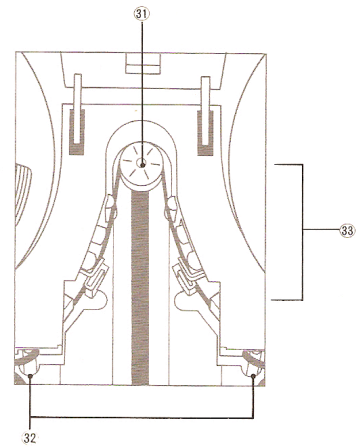
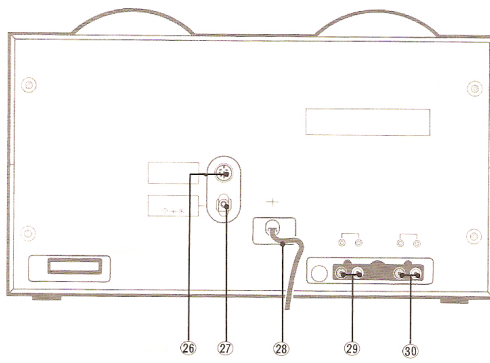
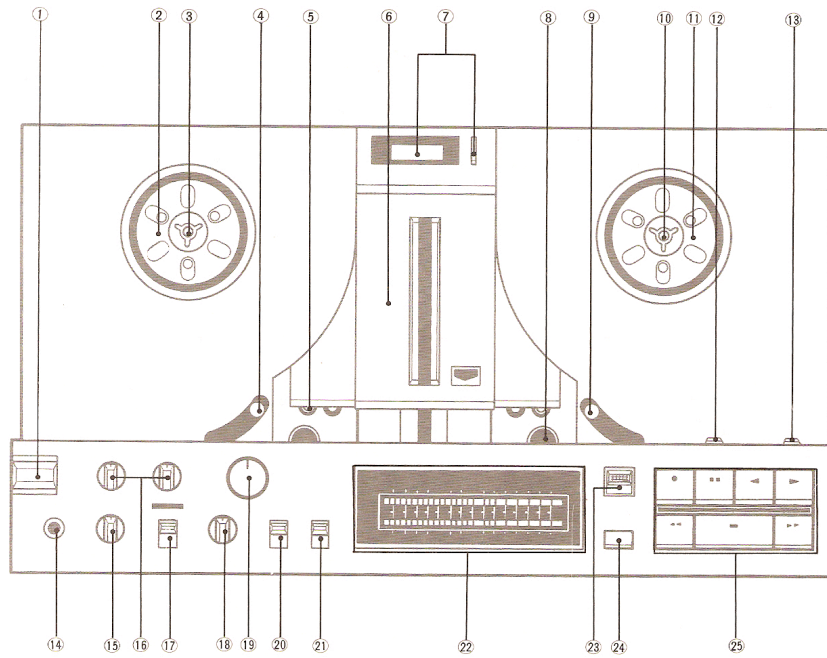

CONTROLS

1. **POWER Switch**
Press once to switch on the GX-77 and once again to switch off the GX-77.
* The REAL TIME COUNTER and the standby indicator (P or I) will light as the power is turned on.
2. **Supply Reel Table**
3. **Reel Stopper**
4. **Tension Arm**
Takes up the tape smoothly and prevents sudden tightening of the tape.
5. **Capstan**
6. **Head Cover**
Pull the bottom towards you to open.
7. **REAL TIME COUNTER and RESET Button**
Displays the amount of tape travel in real time (minutes and seconds) up to 99 minutes 59 seconds and decreases when travelling in reverse. Press the RESET button and the counter will revert to '0000'.
* When 2000' tape (740m±2.400ft) is used at 9.5cm/sec, the tape counter will be reset to '0000' once 99.59 is reached.
8. **Pinch Roller**
Presses the tape against the capstan during playback and recording.
9. **Tension Arm**
Takes up the tape smoothly and prevents sudden tightening of the tape. It works in conjunction with the auto stop mechanism.
10. **Reel Stopper**
11. **Take Up Reel Table**
12. **TIMER START Selector**
Use during absentee recording and timed playback. Always ensure that this switch is at OFF position and the timer start mechanism released during normal recording and playback.
* If the timer start mechanism has not been released and the power is on with a tape loaded, the GX-77 will automatically go into either the recording or playback mode.
13. **Reverse (REV) SELECTOR**
Set the REV SELECTOR to one way (←) recording or playback, one cycle (↔) recording or playback or continuous (→) playback.
14. **Headphone (PHONES) Jack**
Plug in headphones for monitoring recording or playback with headphones.
15. **OUTPUT Control**
Enables simultaneous adjustment of the line output level and the headphone level.
* This cannot alter the Digital Bar Meter.
16. **Recording Input Controls [REC-L, REC-R]**
Adjust the recording input level and the balance between left and right channels. Adjust REC-L for the left channel and REC-R for the right.
17. **MONITOR Selector**
Set to SOURCE when adjusting the recording input level and to TAPE when monitoring playback or monitoring the just recorded signal.
18. **BIAS Adjustment (ADJUST) Control**
Set to the type of tape being used for recording and adjust within ±30%.
19. **Recording (REC) MASTER Control**
Adjusts the overall recording input level independently of the Recording Input controls. Useful for fade-in, fade-out recording etc.
20. **TAPE Selector**
Adjusts to the type of tape being used for recording or playback.
Tape selector with a special EE (extra efficiency) position for the high performance tapes.
21. **TAPE SPEED Selector**
Changes the recording and playback tape speeds.
22. **Digital Bar Meters**
Display the recording input and playback levels. A built-in peak hold holds maximum levels over 0 dB for about one second. The upper meter (L) indicates the left channel and the lower (R) indicates the right.
* The display cannot be altered by the OUTPUT control.
23. **CUE/REVIEW Lever**
Press this lever to cue in the beginning of a song from fast forward or rewind during playback.
Press once more to release.
* Ensure this lever is not pressed when recording or playing back.
24. **LOADING ROLLER UP/DOWN Button**
25. **Operation Buttons**
Recording Button (● REC) and Indicator

To record forwards, press this button and the forward button (▶) simultaneously. To record in reverse, press this button and the reverse button (◀) simultaneously.

PAUSE Button (⏸) and Indicator

Press to stop tape travel temporarily during recording or playback.
* The indicator will light during the pause mode.

Reverse Button (◀)

Press this button for reverse playback and for reverse recording press this button and the recording button (● REC) together. The reverse STANDBY/DIRECTION indicator will light.

Forward Button (▶)

Press this button for forward playback and for forward recording press this button and the recording button (● REC) together. The forward STANDBY/DIRECTION indicator will light.

Rewind Button (◀◀)
Press to rewind the tape in the direction of the arrows.

Stop Button (■)

Press to stop playback, recording, fast forward, rewind, pause.

Fast Forward Button (▶▶)

Press this button to fast forward the tape in the direction of the arrows.

Note: To ensure stable operation of the timer start mechanism, please allow about 5 seconds to elapse after switching the power on and before pressing the operation buttons.

STANDBY/DIRECTION Indicators (◀ and ▶)
Indicate standby during pause, rewind or fast forward. During playback and recording indicate the direction of tape travel.

26. **REMOTE Control Jack**
Plug in the optional Remote Control Unit RC-21 or RC-90 for remote control operation.
* Please use only the remote control unit specified above.

27. **External Power Supply Jack (INPUT DC 15V)**

Plug in the optional AC Adapter MP-515. This enables the figures on the tape counter to be retained even after the power has been turned off. Please do not use any AC adapter other than the MP-515 (sold separately).

28. **Power Cord**

29. **LINE IN Jacks**

These are the line input jacks for recording from other tape decks (LINE OUT jacks) or through an external amplifier (TAPE REC jacks).

30. **LINE OUT Jacks**

These are the line output jacks for dubbing to another tape deck (LINE IN jacks) or for monitoring while connected to an external amplifier (TAPE PLAY jacks).

31. **Loading Roller**
Rises up during tape travel to enable recording and playback.

32. **Sensing Pins**

When the sensing tape affixed to the tape reaches these sensing pins, during auto reverse recording and continuous playback, the direction of tape travel is reversed. The one on the supply reel side is for forward to reverse and the one on the take up reel side is for reverse to forward.

33. **Head Section**

From bottom left hand side, are the reverse playback GX head, recording GX head, erase head and tape guide.
From bottom right hand side are the forward playback GX head, recording GX head, erase head and tape guide.

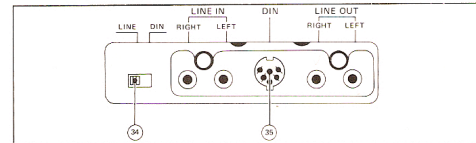

34. **LINE/DIN Selector (Some models do not have this facility.)**

LINE: Set to this position for input from the LINE IN jacks.

DIN: Set to this position for input from the DIN jacks.

35. **LINE Jack (Some models do not have this facility.)**

Can be used instead of the LINE IN and OUT jacks for connection with an external amplifier through a DIN connection cord.

* To avoid cross-talk, do not operate the machine with input sources connected to both the LINE and DIN input jacks. (Disconnect plugs from inputs not being used prior to operation.)

CONNECTIONS

- Switch off all the components before connecting.
- Insert the connection plugs firmly into the connection jacks.
- Please keep plugs and jacks clean. Dirt causes noise and distortion.
- When using a timer, connect this deck's power cord into either the amplifier's AC outlet or directly to the timer's switched outlet.

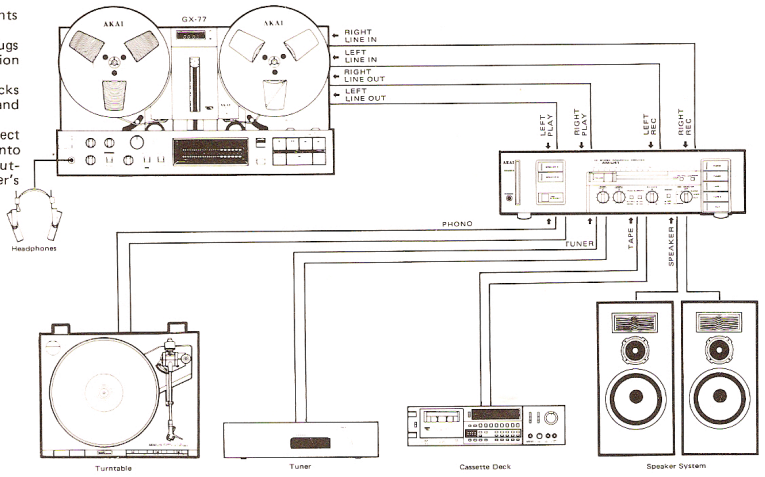

**FOR CUSTOMERS IN THE UK
IMPORTANT FOR YOUR SAFETY**

The flex supplied with your machine will have either two wires or three as shown in the illustrations.

THREE CORE FLEX

WARNING
THIS APPARATUS MUST BE EARTHED.
IMPORTANT

The wires in this mains lead are coloured in accordance with the following code:

- * Green-and-yellow: Earth
- Blue: Neutral
- Brown: Live

As the colours of the wires in the mains lead of this apparatus may not correspond with the coloured markings identifying the terminals in your plug, proceed as follows:

The wire which is coloured green-and yellow must be connected to the terminal in the plug which is marked by the letter E or by the safety earth symbol  or coloured green or coloured green-and-yellow.

The wire which is coloured blue must be connected to the terminal which is marked with the letter N or coloured black.

The wire which is coloured brown must be connected to the terminal which is marked with the letter L or coloured red.

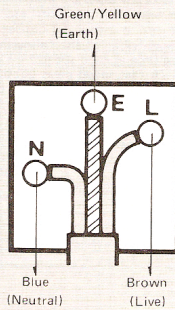

TWO CORE FLEX

IMPORTANT

The wires in this mains lead are coloured in accordance with the following code:

- Blue: Neutral
- Brown: Live

As the colours of the wires in the mains lead of this apparatus may not correspond with the coloured markings identifying the terminals in your plug, proceed as follows:

The wire which is coloured blue must be connected to the terminal which is marked with the letter N or coloured black.

The wire which is coloured brown must be connected to the terminal which is marked with the letter L or coloured red.

* Do not connect any wire to the larger pin marked E or  when wiring a plug. Ensure that all terminals are securely tightened and that no loose strands of wire exist.

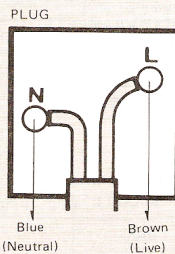

FOR CUSTOMERS IN AUSTRALIA

If your machine comes with a three core power cord, FOR YOUR SAFETY:

1. Insert this plug only into an effectively earthed three-pin plug socket outlet.
2. If any doubt exists regarding the earthing, consult a qualified electrician.
3. Extension cords, if used, must be three-core correctly wired.

FOR CUSTOMERS IN THE U.S.A.

SAFETY INSTRUCTIONS

1. Read Instructions — All the safety and operating instructions should be read before the equipment is operated.
2. Retain Instructions — The safety and operating instructions should be retained for future reference.
3. Heed Warnings — All warnings on the equipment and in the operating instructions should be adhered to.
4. Follow Instructions — All instructions for operating and use should be followed.
5. Water and Moisture — The equipment should not be used near water — for example, near a bathtub, washbowl, kitchen sink, laundry tub, in a wet basement, or near a swimming pool, etc.
6. Carts and Stands — The equipment should be used only with a cart or stand that is recommended by Akai.
7. Wall or Ceiling Mounting — Akai does not recommend mounting the equipment on a wall or a ceiling.
8. Ventilation — The equipment should be situated so that its location or position does not interfere with its proper ventilation. For example, the equipment should not be situated on a bed, sofa, rug, or similar surface that may block the ventilation openings; or, placed in a built-in installation, such as a bookcase or cabinet that may impede the flow of air through the ventilation openings.
9. Heat — The equipment should be situated away from heat sources such as radiators, heat registers, stoves, or other equipments (including amplifiers) that produce heat.
10. Power Sources — The equipment should be connected to a power supply only of the type described in the operating instructions or as marked on the equipment.
11. Grounding or Polarization — The precautions should be taken so that the grounding or polarization means of an equipment is not defeated.
12. Power-Cord Protection — Power-supply cords should be routed so that they are not likely to be walked on or pinched by items placed upon or against them, paying particular attention to cords at plugs, convenience receptacles, and the point where they exit from the equipment.
13. Cleaning — The equipment should be cleaned only as recommended by the manufacturer.
14. Power Lines — An outdoor antenna should be located away from power lines.
15. Outdoor Antenna Grounding — If an outside antenna is connected to the receiver, be sure the antenna system is grounded so as to provide some protection against voltage surges and built up static charges. Section 810 of the National Electrical Code, ANSI/NFPA No. 70-1981, provides information with respect to proper grounding of the mast and supporting structure, grounding of the lead-in wire to an antenna discharge unit, size of grounding conductors, location of antenna-discharge unit, connection to grounding electrodes, and requirements for the grounding electrode. See Figure 1.
16. Nonuse Periods — The power cord of the equipment should be unplugged from the outlet when left unused for a long period of time.
17. Object and Liquid Entry — Care should be taken so that objects do not fall and liquids are not spilled into the enclosure through openings.
18. Damage Requiring Service — The equipment should be serviced by qualified service personnel when:
 - A. The power-supply cord or the plug has been damaged; or
 - B. Objects have fallen, or liquid has been spilled into the equipment; or
 - C. The equipment has been exposed to rain; or
 - D. The equipment does not appear to operate normally or exhibits a marked change in performance; or
 - E. The equipment has been dropped, or the enclosure damaged.
19. Servicing — The user should not attempt to service the equipment beyond that described in the operating instructions. All other servicing should be referred to qualified service personnel.

Fig. 1
EXAMPLE OF ANTENNA GROUNDING AS
PER NATIONAL ELECTRICAL CODE INSTRUCTIONS

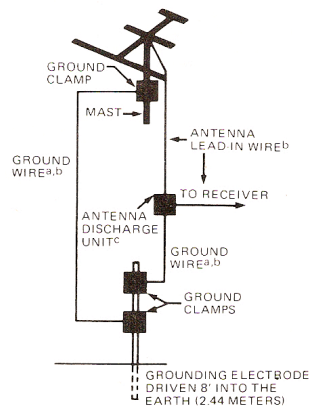

- a. Use No. 10 AWG (5.3 mm²) copper, No. 8 AWG (8.4 mm²) aluminum, No. 17 AWG (1.0 mm²) copper-clad steel or bronze wire, or larger, as ground wire.
- b. Secure antenna lead-in and ground wires to house with stand-off insulators spaced from 4 feet (1.22 m) to 6 feet (1.83 m) apart.
- c. Mount antenna discharge unit as close as possible to where lead-in enters house.

Tapes

Tape Care

- Fingering the magnetic surface of the tape causes signal dropout. Particular care should be taken with open reel tapes.



- Recordings cannot be made on the leader tape at the beginning and end of the tape. Forward the tape until there is no leader tape in the head path before recording.



- Please do not leave tapes loaded on the deck over long periods of time. Remove after use, replace in their boxes and store in a cool, dry place away from units producing magnetic fields such as speakers or TVs.

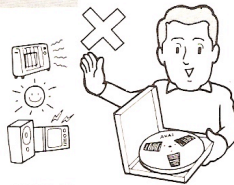

- Long-period storage of tapes that was taken up in a fast forward or rewind mode will cause damage to the tape, leading to unexpected troubles or will make them unfit for use. Therefore, the tapes should be stored in a condition as taken up in an orderly manner with the tape traveling at the fixed speed of recording or playback. However, either rewind or fast forward the entire tape before using the tape after storage.

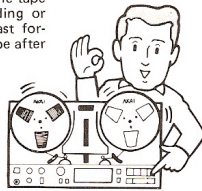

- Do not bend or force the tapes. Faulty reels can cause unstable tape travel so avoid loose or warped reels.

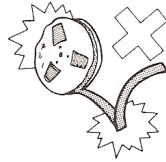

Tape Recording Time

Marketed tapes are available in lengths of 740m (2,400ft), 550m (1,800ft) and 370m (1,200ft) etc. The TAPE SPEED selector on this deck can be set to either 19 cm/sec. (7-1/2 in.) or to 9.5 cm/sec. (3-3/4 in.). Please refer to the following chart for the length of recording and playing time at each speed.

* A fast speed gives good wow and flutter and frequency characteristics but it also shortens playing time.

Tape Speed	Tape Length			
	740m (2400ft)	550m (1800ft)	370m (1200ft)	
19cm/sec (7½ in)	One-way	60	45	30
	Two-way	120	90	60
9.5cm/sec (3¾ in)	One-way	120	90	60
	Two-way	240	180	120

Setting The Tape Selector

Please refer to the chart for the correct TAPE SELECTOR settings for marketed tapes.

TAPE SELECTOR	NORMAL	EE
BRAND		
AKAI	LN, WR	
SCOTCH	≠ 176, ≠ 177, ≠ 206, ≠ 207 ≠ 218, ≠ 250, ≠ 1500, ≠ 2000	
SONY	ULH, DUAD	
TDK	GX, LX	SA open
MAXELL	LN, UD, XL	XL II open
BASF	LH	
DENON	DX	

The standard reference tape is the 150% (550m) in bold type. Each tape position has been adjusted for the reference tape.

* Please set the BIAS Adjustment (ADJUST) Control to '0' when recording with tapes designated as standard reference tapes.

Extra Efficiency (EE) Tapes



The TAPE SELECTOR has a position (EE) for the high performance Extra Efficiency tapes. When recording with EE tapes, set the TAPE SELECTOR to EE and set the BIAS ADJUST control to "0".

GX Head

When compared with other heads the GX heads in this deck are highly efficient with their decreased magnetic change loss and subsequent corresponding decrease in the amount of compensation to the equalizer circuit. This decrease in compensation can thus be actively used to improve the tape's magnetic characteristics. In particular the compensation for high frequency characteristics improves the high frequency high level recording. Moreover although the noise inherent in the tape and the built-in amplifier is increased by the equalizer circuit, the amount of decreased compensation decreases the noise contributing to an improved signal to noise ratio.

Setting the BIAS Adjustment (ADJUST) Control

This deck has been supplied with a BIAS ADJUST control which can adjust the bias by $\pm 30\%$ at each tape position. Particularly when using tape at the normal position, please refer to the chart below to set the BIAS ADJUST control.

* Turning the BIAS ADJUST control completely to the left or right will change the bias too sharply and change the frequency characteristics.

BRAND	TAPE	Position	BRAND	TAPE	Position
AKAI	WR 150	0	Scotch	#212	-1.5
	XL II (REFERENCE)	0		#213	-4.5
MAXELL	UD (REFERENCE)	0	Scotch	#206	-2.0
	XL 35 90B	0		#250	+0.5
TDK	SA (REFERENCE)	0	Scotch	#176	-2.0
	GX35 90B	0		#1500	+0.5
SONY	LX35 90	0	Scotch	#2000	-2.0
	ULH7 550	0		#177	-1.5
DENON	DX 550	-2.0			

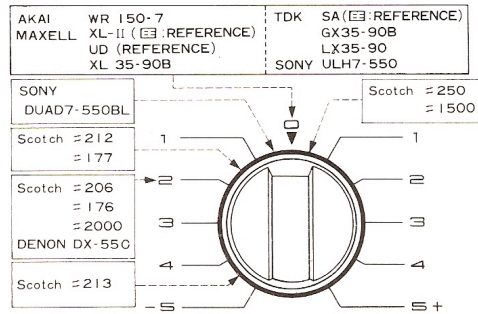

RECORDING AND PLAYBACK SYSTEM

4 Track, 2 Channel Recording and Playback Systems

With the 4 track system each track occupies 1/4 of the tape width and with the 2 channel system (GX-77) 2 tracks are used to record and playback left and right channels. Tracks 1 and 3 are used for the left and right channels when recording in forward direction and 2 and 4 are used for the left and right when recording in reverse direction. Thus on one tape there can be 2 channel recording and playback both ways.

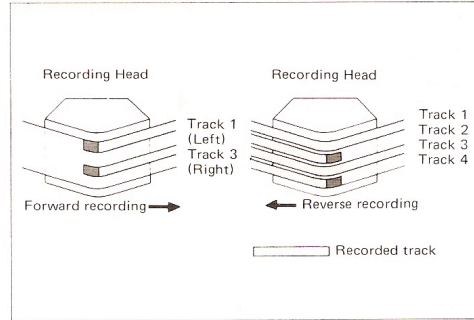

Tape Loading

New tapes have adhesive tapes attached at the ends. As these tapes may stick to such parts as the capstan and tension arms, please remove them before use.

1. Place a full reel of tape on the supply reel table and an empty reel of the same size on the take up reel table. Pull the reel stoppers at the tips of reel table shafts outwards and turn to the left or right to lock into place.

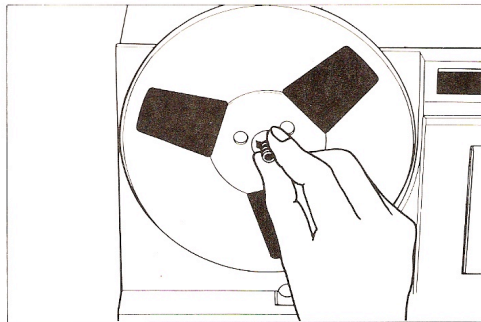

2. Unwind about 60 to 70 cms of tape and then thread into the empty reel as shown in the diagram.

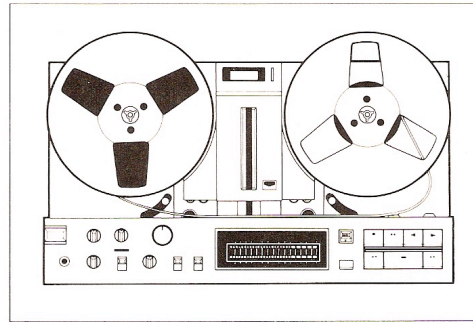

3. Insert the end of the tape into the slot in the hub on the empty reel.

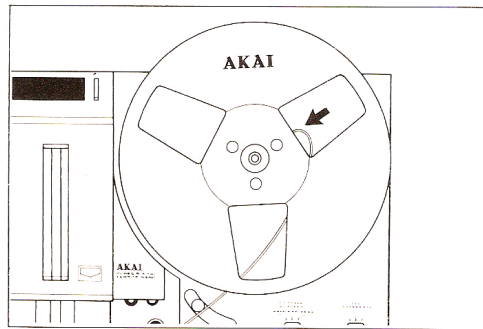

4. Gently hold the tape in position with the right forefinger and wind the empty reel around in a counterclockwise direction once or twice until all the tape slack has been taken up.

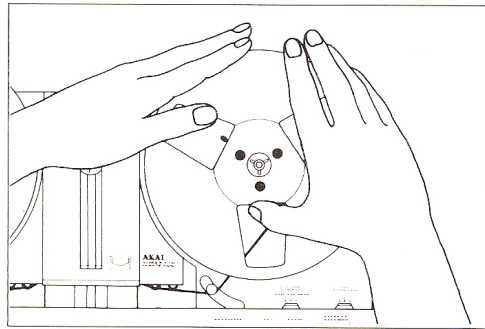

Auto Loading Mechanism

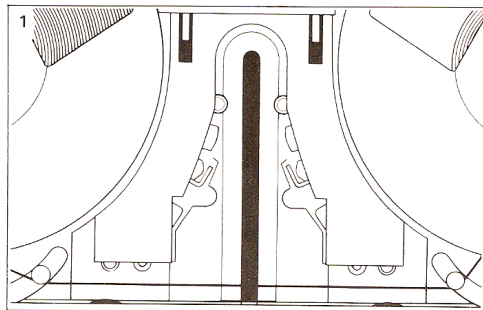

This new mechanism was developed to put aside the idea that loading open reel tapes is time consuming and difficult.

1. Simply thread the tape under the tension arms and onto the take up reel as described before.

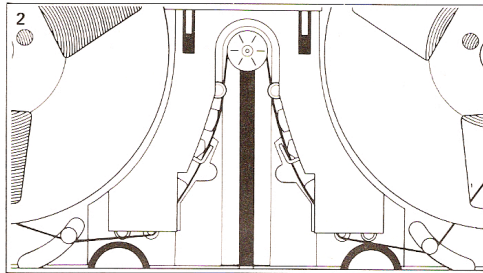

2. Press the **LOADING ROLLER UP/DOWN** button and the auto mechanism will take the tape to the heads and begin tape travel.

3. When all the tape has been transferred to the take up reel the auto loading mechanism will release as auto stop is activated.

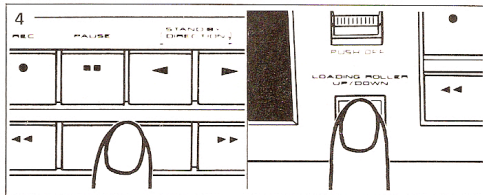

4. Press the **Stop** button (■) and then the **LOADING ROLLER UP/DOWN** button to stop tape travel and release the auto loading mechanism midway.

- * Loading mechanism cannot be stopped by pressing the **LOADING ROLLER UP/DOWN** button during tape travel.
- * With auto loading it takes about one second for tape travel to begin after the **LOADING ROLLER UP/DOWN** button has been pressed.
- * When the tape deck is not to be used for a longer period of time, unload the tape and take off the tape reel.

Recording (Forwards)

Before beginning:

- Is the tape correctly loaded? (See pages 6 and 7.)
- Is the Power Cord connected?
- Is everything correctly connected? (See page 3.)
- Is the TIMER START selector set to OFF?

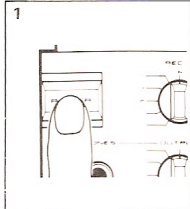

1. Press the POWER switch to turn on the power.

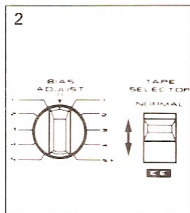

2. Set the TAPE SELECTOR and the BIAS Adjustment (ADJUST) control to the tape being used.

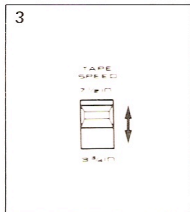

3. Set the TAPE SPEED selector to the desired speed.

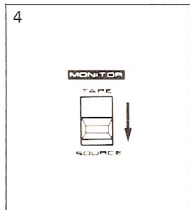

4. Set the MONITOR selector to SOURCE.

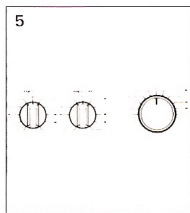

5. Adjust the balance between the left and right channels with the Recording Input controls (REC-L and REC-R) and then the overall recording input level with the Recording (REC) MASTER control.

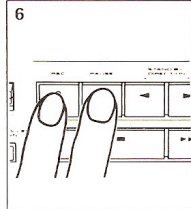

6. Press the REC (●) and PAUSE (■) buttons for recording standby.

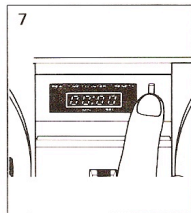

7. Press the RESET button and set the REAL TIME COUNTER to '0000'.

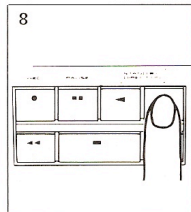

8. Press the Forward (▶) button, the tape will travel forwards and recording begin.

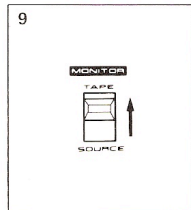

9. Set the MONITOR selector to TAPE for simultaneous monitoring and adjust the recording level while checking the recording.

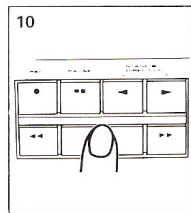

10. Press the Stop (■) button to release.

Cutting Out The Commercials During FM Recording

1. Set the MONITOR selector to SOURCE before the commercial begins and monitor the source.
2. Press the PAUSE (■) button as the commercial begins to stop tape travel while keeping the deck in the recording mode.
3. When the commercial finishes press the Forward (▶) button to resume recording.
4. Use also when jumping tracks while recording records.

Setting The Recording Input Level

Please adjust the recording level for a good signal to noise ratio. If the recording level is too low, noise will result and if too high, distortion will increase.

1. Set the MONITOR selector to TAPE while recording. (Simultaneous monitoring).
 2. The Digital Bar Meter indicates the level being recorded onto the tape. Watch the Digital Bar Meters and adjust the balance between left and right channels with the Recording Input controls (REC-L and REC-R) and the overall recording input level with the Recording (REC) MASTER control.
 3. Refer to the illustrations on the right.
- * This adjustment should be sufficient for normal use but there are variations in the recording sensitivities of tapes. We advise you to monitor simultaneously the sound being recorded through headphones, etc. to adjust the recording level correctly. The GX heads featured in this deck decrease loss during recording and playback to give recording without distortion when wide dynamic range, high performance tapes are used in particular even if 0 dB is occasionally exceeded. Monitor simultaneously through the headphones to raise the recording level until just before distortion becomes noticeable, in order to widen the dynamic range for recording with a good signal to noise ratio.

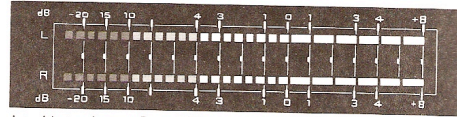

Level is too low. → Poor S/N.

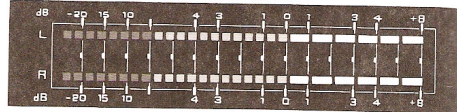

Correct. → Good recording.

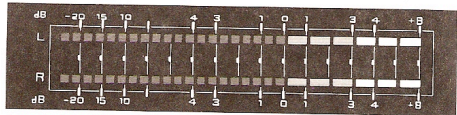

Level is too high. → Distortion appears.

Simultaneous Monitoring

Use this method to check the quality of recording during recording. It will help to record important programs well and to avoid the distortion produced when the input level is too high.

- Set to the MONITOR selector to SOURCE to monitor the recording input signal. (Routes 1 and 2 on the diagram)
- Set the MONITOR selector to TAPE to monitor what is actually being recorded on the tape. (Routes 1 and 3 on the diagram)

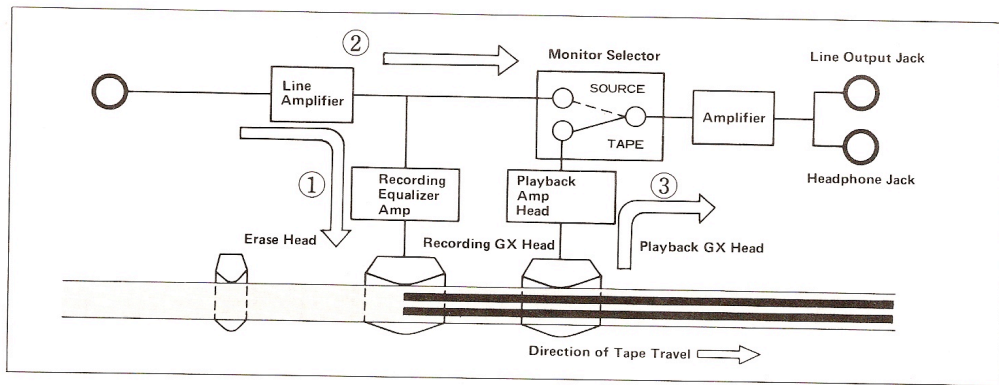

Add On Recording

During playback, if the REC (●) button is pressed along with the Forward (▶) or the Reverse (◀) button recordings can be made without interrupting tape travel.

Playback (Forwards)

Before beginning:

- Is the tape correctly loaded? (See pages 6 and 7.)
- Is the Power Cord connected?
- Is everything correctly connected? (See page 3.)
- Is the TIMER START selector set to OFF?

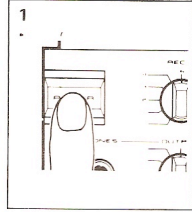

1. Press the POWER switch to turn on the power.

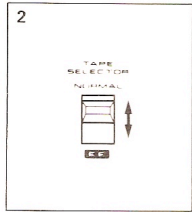

2. Set the TAPE SELECTOR for the tape being used.

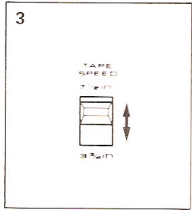

3. Set the TAPE SPEED selector to the speed at which the recording was made.

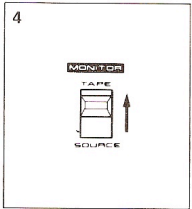

4. Set the MONITOR selector to TAPE.

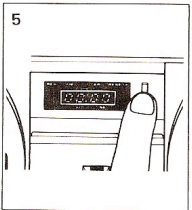

5. Press the RESET button and set the REAL TIME COUNTER to '0000'.

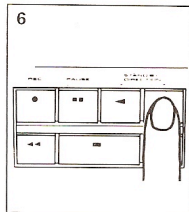

6. Press the Forward (▶) button, the tape will travel and playback will begin.

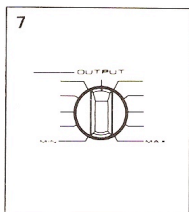

7. Adjust the headphone volume and output to the pre-main amplifier (or receiver) with the OUTPUT control.

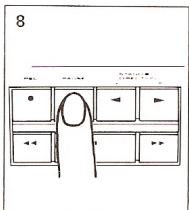

8. Tape travel can be temporarily stopped by pressing the PAUSE (■) button. Press the Forward (▶) button to resume playback.

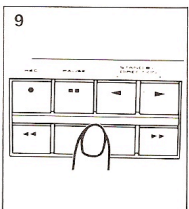

9. Press the Stop (■) button to release.

Setting the Output Level

An OUTPUT control has been supplied on this deck to match the deck's output level to the outputs from other sources such as your tuner or turntable, etc. Please adjust as follows:

1. Set the Input selector on the external amplifier to Tuner, the Monitor selector to Source and listen to an FM broadcast.
2. Adjust the amplifier's volume for normal listening.
3. Record as much of the FM broadcast as required on to this deck.
4. Set the Monitor selector on the external amplifier to Tape and listen to the playback.
5. Compare the volume of the recording with the FM broadcast and alter the deck's OUTPUT control until they are the same.

CUE/REVIEW Operation

Use the CUE/REVIEW lever to find the beginning of a song during playback.

1. Press down the CUE/REVIEW lever.
2. If the tape is travelling in the forward direction (▶ indicator is lit):
Press the Fast Forward (▶▶) button. The deck will advance and at the same time playback the tape quickly in the direction of the arrows (▶▶).
Press the Rewind (◀◀) button. The deck will advance and at the same time playback the tape quickly in the direction of the arrows (◀◀).
If the tape is travelling in the reverse direction (◀ indicator is lit):

Press the Fast Forward (▶▶) button. The deck will advance and at the same time playback the tape quickly in the direction of the arrows (▶▶).

Press the Rewind (◀◀) button. The deck will advance and at the same time playback the tape quickly in the direction of the arrows (◀◀).

3. When the desired section is reached, press the Stop (■) button.
4. To resume playback, depress the CUE/REVIEW lever to release the operation.
5. Press the Forward (▶) or Reverse (◀) button.

Reverse Recording

Change the direction of tape travel at a suitable point without stopping the recording.

1. Press the Reverse (◀) button to change direction from forward to reverse and the Forward (▶) button to change from reverse to forward.

2. Leave in the recording mode and the direction will change in about one second.

* The position of the Reverse (REV) SELECTOR has no effect on manual reverse operation.

Auto Reverse Recording

Attach a 2.5 to 4 cm length of standard accessory sensing tape to the back of the tape at the point where you want to change direction. When the sensing pin on the supply reel side comes in contact with the sensing tape the direction will be automatically changed without interrupting recording. See the chart for the Reverse selector setting.

- * Do not attach the sensing tape to any place on the tape other than where the direction is to change.
- * Reverse to forward auto reverse is impossible.
- * Please note that during one cycle recording of a previously recorded tape, about one second of the previous recording cannot be erased when the deck changes to reverse. Please erase this portion manually.
- * During quick reverse the input signal is interrupted for about 0.5 seconds. Nothing can be recorded during this interruption.

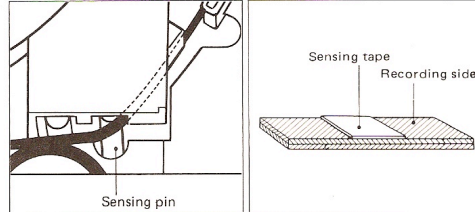

RECORDING		
Position of Reverse Selector	Tape Travel	Operation
ONE-WAY 	1. Forward only 	1. When the Recording (REC ●) and Forward (▶) buttons are pressed simultaneously, recording in forward direction is possible. * The deck will go into stop mode at the end of the tape.
	2. Reverse only 	2. When the Recording (REC ●) and Reverse (◀) buttons are pressed simultaneously, recording in reverse direction is possible. * The deck will go into stop mode at the end of the tape.
ONE CYCLE (Forward-Reverse Only) 	3. 	3. When the Recording (REC ●) and Forward (▶) buttons are pressed simultaneously, after once cycle (forward to reverse only) of recording is complete (all the tape is taken up on one reel) the deck will go into stop mode. * During recording, even if the REV SELECTOR is set to ◀, the deck will go into one cycle recording to prevent recording over of already recorded tape.
CONTINUOUS (Forward-Reverse Only) 		3. When the Recording (REC ●) and Reverse (◀) buttons are pressed simultaneously, recording in reverse direction only is possible.

Continuous Playback

Attach two pieces of sensing tape at the two points where the direction of tape travel is to be changed. When the sensing tape comes in contact with the sensing pin the direction will change automatically. Thus continuous playback forward to reverse to forward and so on is possible. Set the Reverse (REV) SELECTOR to \rightleftarrows and refer to the chart for a more detailed explanation.

- * Recording will take place as in \rightarrow mode.
- * Do not attach sensing tape to any point other than where you want to change direction for continuous playback.

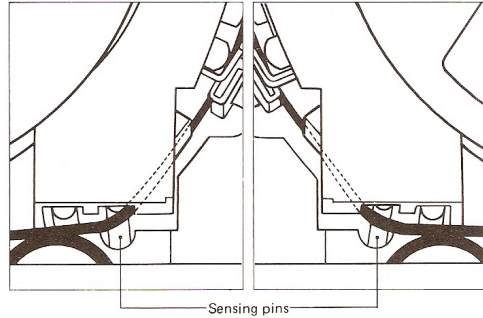
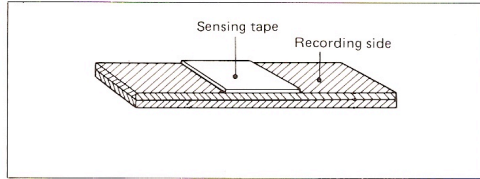

PLAYBACK		
Position of Reverse Selector	Tape Travel	Operation
ONE-ONE-WAY	1 Forward only 	1. When the Forward (▶) button is pressed, playback in forward direction is possible. * The deck will go into stop mode at the end of the tape.
	2 Reverse only 	2. When the Reverse (◀) button is pressed, playback in reverse direction is possible. * The deck will go into stop mode at the end of the tape.
ONE CYCLE (Forward → Reverse only)	3 	3. When the Forward (▶) button is pressed, after once cycle (forward to reverse only) of playback is complete (all the tape is taken up on one reel) the deck will go into stop mode.
CONTINUOUS	4 	4. When the Forward (▶) or the Reverse (◀) button is pressed, the deck will go into continuous playback. Press the stop (■) button to stop playback.

Absentee Recording

Before beginning:

- Prepare the timer and make all the necessary connections. Connect the Power Cord.
- Check that the timer is set to the correct time.

1. Set the timer to EVER-ON or ON.

* There are differences between the timers on the market so please refer to the timer's operator's manual for the correct procedure for your timer.

2. Turn on the power to the deck and the other components connected to the timer and prepare for recording. See page 7.

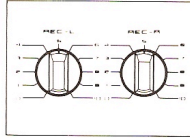

3. Set the REV SELECTOR.

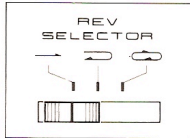

4. Press the deck's PAUSE (■ ■) button.

When recording in forward direction press the Forward (►) and REC (●) buttons simultaneously.

* If recording is to begin in the reverse direction, press the Reverse (◄) and REC (●) buttons simultaneously.

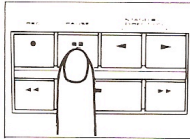

- Check how long the tape can record.
- Set the TAPE SELECTOR and BIAS correctly for the tape being used.
- Set the TAPE SPEED selector to the desired recording speed.

5. Depress the stop button (■) to release recording standby.

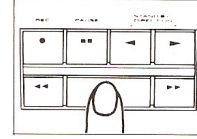

6. Set the TIMER START selector on this deck to REC.

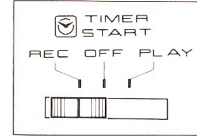

7. Set the timer start time and length of recording time, then set the timer to AUTO or TIMER the deck and other components will be turned off.

* If this deck is connected to a multi program timer, continuous recording for a long period is possible.

* All the components will be turned on and the deck will go into recording mode at the designated time.

- Once absentee recording has finished the power supply will be automatically cut to the components but please ensure the TIMER START selector is OFF before switching on the power to this deck again.

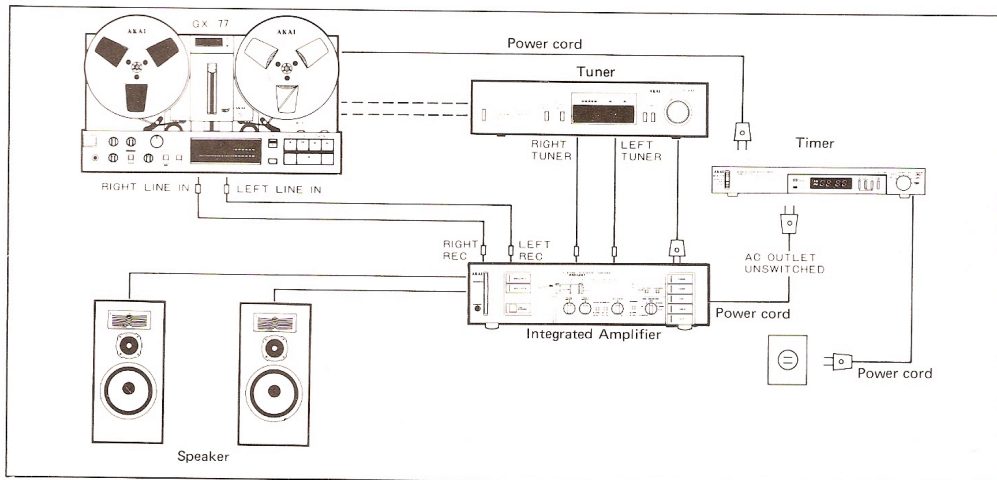



Timed Playback

Before beginning:

- Prepare the timer and make all necessary connections. Connect the Power Cord.
- Check the timer is set to the correct time.

1. Set the timer to EVER ON or ON.
* There are differences between the timers on the market so please refer to the timer's operator's manual for the correct procedure for your timer.

2. Switch on the power to the deck and other components connected to the timer and prepare for playback. See page 10. Adjust the volume from the speakers.

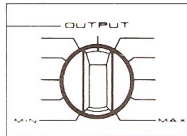

3. Set the REV SELECTOR.

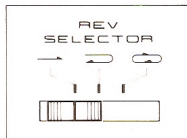

4. When playback is to begin in forward direction, press the forward button (▶) and check the tape is travelling forwards.

* If playback is to begin from the reverse direction, press the reverse button (◀) and check the tape is travelling in the reverse direction.

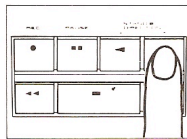

- Set the TAPE SELECTOR for the tape to be played.
- Set the TAPE SPEED selector to the speed at which the recording was made.

5. Depress the stop button (■) to release playback.

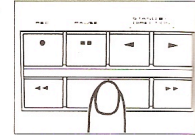

6. Set the TIMER START selector on this deck to PLAY.

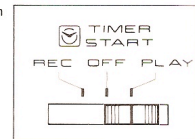

7. Set the timer start time and the length of playing time and then set the timer to AUTO or TIMER the deck and other components will be turned off.

8. The deck is now ready for timed playback.

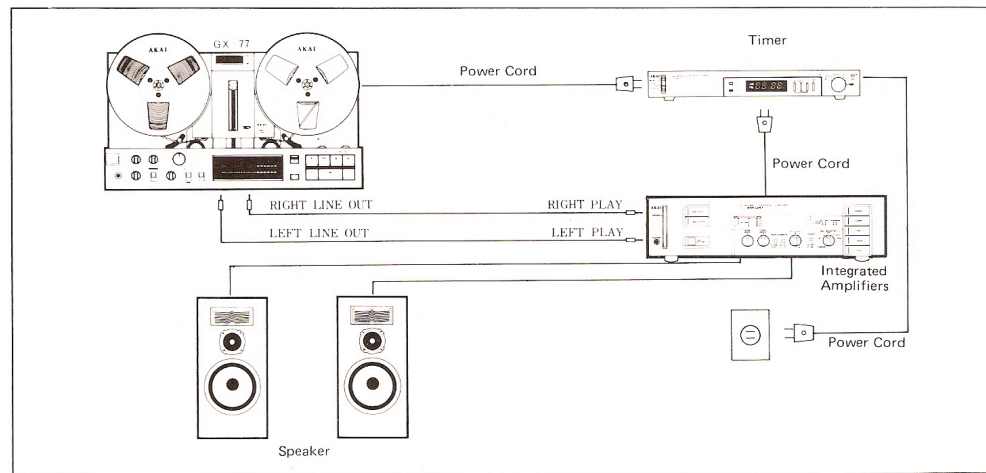

Tape Dubbing

Follow the procedure outlined below to make an exact copy of a recorded tape or to edit and change the order of programs recorded from FM.

Dubbing From The GX-77 To A Cassette Deck

- Connect an additional cassette deck.
- Refer to the connections diagram on page 3 or the one below.
- Switch on the power to all the components.

PLAYBACK DECK	RECORDING DECK
Place the recorded tape on the GX-77 to be used for playback.	1
	2
Set the GX-77 to playback.	3
	4
Set the GX-77's OUTPUT control to maximum.	5
	6
Wind the playback tape back to the beginning of the selection.	7
	8
Put the GX-77 into playback mode.	9

See respective instructions for pausing.

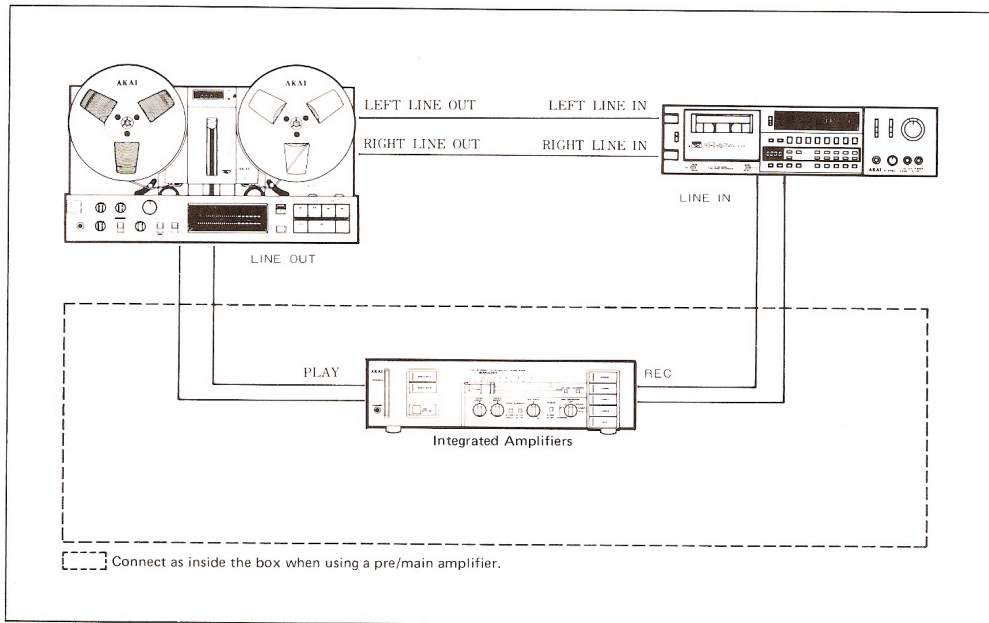



Tape Editing

This is a 4 track deck but please follow the procedure below for editing a tape which has a recording in only one direction. If you intend to splice a tape which has recordings in both directions, please remember that the cut on one side will affect the other's recording continuity.

Marking The Beginning Of A Program

Please raise the head cover during this operation.

1. Playback the tape and monitor through headphones or speakers. Press the PAUSE (⏸) button at the desired point.
2. Press down the CUE/REVIEW lever.
3. Turn both the reels by hand until the blank portion between songs is reached.
4. Once the correct position has been reached, take the portion of tape at the middle of the playback head and mark it with a dermatograph available on the market. This is now the beginning of the program.
 - * Please do not mix up the forward and reverse playback heads.

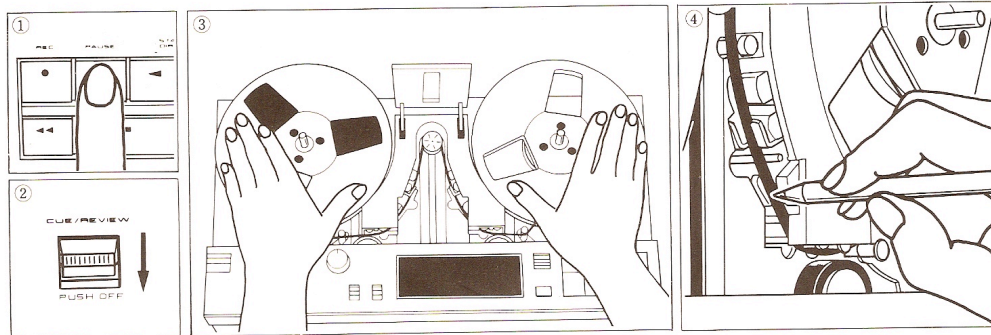
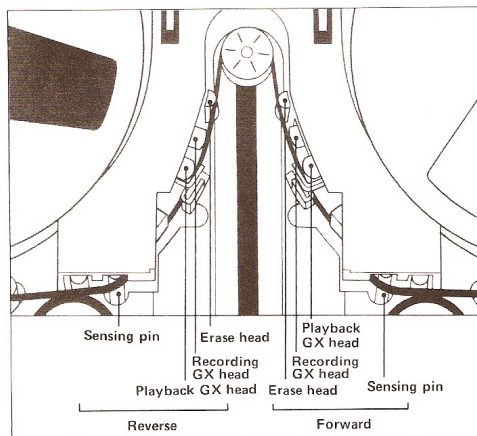

Tape Splicing

1. After marking the position place the marked portion into the groove on the standard accessory splicing block.
 - * The marker should be over the center of the slanted groove.
2. Place the tape to be connected over it and cut into the groove as shown.
3. Remove the excess tape and affix the splicing tape. Rub firmly with a finger to prevent the splicing tape from coming off.
 - * Only use splicing tape for joining tapes.
4. Remove the tape from the block and remove the excess splicing tape.
 - When a recorded tape has broken match the ends and repair with splicing tape.
 - * The tape may be cut with scissors but it will adversely affect the recording if magnetized scissors are used.

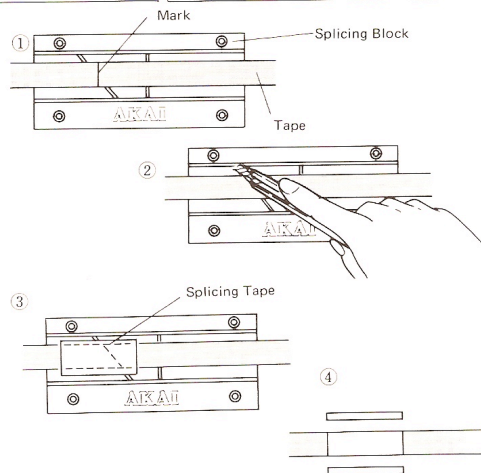

Maintenance

Cleaning

Please use Akai's cleaning kit HC-550P, sold separately.

- Poor high notes Please clean the recording, playback heads and capstan.
- Dropout
- Non recording Please clean the erase heads.
- Partial erasure Please clean the loading roller, pinch roller, guide roller, capstan, tension arms and tape guides.
- Unstable tape run

It is particularly important that the parts which come in contact with the tape, like the recording, playback and erase heads, capstan, tension arms, tape guides and loading roller be cleaned for auto reverse recording using sensing tape.

Method

Please clean with cotton swab sticks dipped in the cleaning fluid. See picture.

The pinch and guide rollers are easily cleaned with a cloth wrung out in cleaning fluid.

Please use a cleaning fluid suitable for rubber for the pinch and guide rollers.

- * Do not use chemicals such as chloroethane, etc. for head block cleaning.

Demagnetizing (Turn off the POWER Switch.)

Please use Akai's demagnetizing kit AH-15, sold separately.

- Poor high notes Please demagnetize the recording and playback heads.
- Noise
- * Demagnetize the capstan, tension arms and tape guides at the same time.

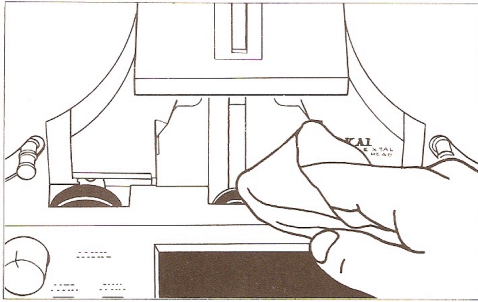
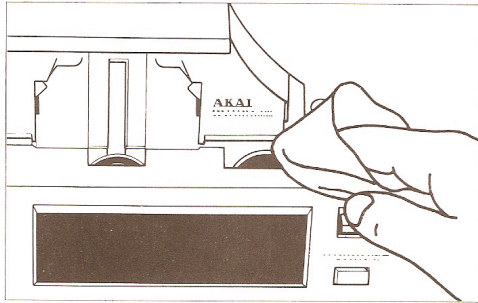



Troubleshooting

The conditions listed below do not indicate mechanical failure of your deck. If your deck exhibits any of these conditions, check for trouble as indicated.

Symptom	Cause	Remedy
No power although the power cord is inserted.	Not properly inserted.	Insert until the power comes on.
Tape will not run even if the operation buttons are pressed.	No power	Switch on power.
	Tape incorrectly loaded.	Correctly reload.
Tape travels forwards or in reverse when the power is switched on.	TIMER START selector set to REC or PLAY.	Switch OFF.
Tape travel is not smooth.	Warped reel.	Change.
	Tape incorrectly loaded.	Reload correctly.
	Dirty tape.	Change.
	Dirt or grease on the pinch and loading rollers.	Clean.
Incomplete erasure of previous recording during recording.	Erase heads dirty.	Clean.
	Not in recording mode.	Put in recording mode.
Poor playback quality.	Playback heads dirty.	Clean.
	Playback heads magnetized.	Demagnetize.
	Old tape.	Change.
Poor recording.	Recording heads dirty.	Clean.
	Recording heads magnetized.	Demagnetize.
	Incorrect TAPE SELECTOR setting.	Correct.
	Old tape.	Change.
Non recording.	Dirty recording heads.	Clean.
Hiss noise.	Recording level too low.	Adjust.
Distortion.	Recording level too high.	Adjust.

Should there be a problem, write down the model name, serial numbers and all pertinent data regarding warranty coverage as well as a clear description of the existing trouble and contact your nearest authorized

Akai Service Station or the Service Department of Akai Company, Tokyo, Japan.

SPECIFICATIONS

Track System	.4 Track 2 Channel Stereo System
Reel Capacity	.Up to 7" reel
Heads	.GX head for recording x 2 .GX head for playback x 2 .Erase head x 2
Motors	.FG Servo D.C. motor for capstan drive x 1 .D.C. motor for reel drive x 2
Tape Speed	.19 cm/s $\pm 0.8\%$ (7-1/2 ips.) .9.5 cm/s $\pm 1.0\%$ (3-3/4 ips.)
Wow & Flutter	.Less than 0.03% WRMS, 0.07% DIN 45 500 at 19 cm/s .Less than 0.04% WRMS, 0.10% DIN 45 500 at 9.5 cm/s
Tape Winding Time	.80 sec. using 360 m (1,200 ft.) Tape
Frequency Response (Using a EE tape)	.25 to 33,000 Hz ± 3 dB (-20 VU) at 19 cm/s; 25 to 26,000 Hz ± 3 dB (0 VU) 25 to 25,000 Hz ± 3 dB (-20 VU) at 9.5 cm/s; 25 to 15,000 Hz ± 3 dB (0 VU)
Signal to Noise Ratio	.Better than 63 dB at 19 cm/s DIN 45500
Harmonic Distortion	.Less than 0.5% at 19 cm/s
Input	.Line: 70 mV (input impedance 47 kohms)
Output	.Line: 0.775V at 0 VU Required load impedance: more than 20 kohms Phone: 1.3 mW/8 ohms at 0 VU
DIN	.Input: 2.0 mV (input impedance 10 kohms) Output: 0.3V Required load impedance: more than 20 kohms
Power Requirements	.120V 60 Hz for U.S.A. & Canada 220V 50 Hz for Europe except U.K. 240V 50 Hz for U.K. & Australia 110V/120V/220V/240V, 50/60 Hz switchable for the other countries.
Dimensions	.440(W) x 244(H) x 227(D) mm (17.3 x 9.6 x 8.9 inches)
Weight	.17.0 kg (37.5 lbs)

STANDARD ACCESSORIES

Sensing Tab Kit	1 set
Connection Cords	1 set
Empty Reel	1
Operator's Manual	1

* For improvement purposes, specifications and design are subject to change without notice.