

AKAI X-150D

OPERATOR'S MANUAL



CROSS-FIELD

Custom Deck

TABLE OF CONTENTS

I GENERAL INFORMATION

1. Specifications	2
2. Controls	3
3. Cross-Field Head	5
4. Recording/Playback for 4-track	6
5. Operational Precautions	7
6. Voltage and Cycle Conversion	8
7. Selection of Tape Speeds	9

II OPERATING INSTRUCTIONS

1. Threading the Tape	10
2. Stereo Playback	10
3. Automatic Shut-Off	11
4. Instant Stop Control	11
5. Stereo Recording	12
6. Recording from Stereo Broadcast	13
7. Recording from Stereo Discs	13
8. Monaural Recording on Tracks No. 1-4	13
9. Monaural Recording on Tracks No. 3-2	14
10. Monaural Playback	15
11. Tape Erasing	15
12. Fast Forward and Rewind	16
13. Monitoring	16
14. Tape Splicing and Editing	16
15. Cleaning Head	17

16. Head Demagnetization	19
17. Tape Duplication	19
18. DIN (One Multiple Connection) Jack	20
19. Ventilation	20

III ACCESSORIES

1. Accessories Optional	21
2. Accessories Standard	23

IV SCHEMATIC

V CONNECTING DIAGRAM

1. SPECIFICATIONS

I GENERAL INFORMATION

Tape Speed	: 3 speeds 1-7/8, 3-3/4 and 7-1/2 ips (15 ips optional)
Wow and Flutter	: Less than 0.12% RMS at 7-1/2 ips Less than 0.15% RMS at 3-3/4 ips Less than 0.20% RMS at 1-7/8 ips
Frequency Response	: 30 to 23,000 cps ± 3 db at 7-1/2 ips 30 to 18,000 cps ± 3 db at 3-3/4 ips 30 to 9,000 cps ± 3 db at 1-7/8 ips
Signal to Noise Ratio	: Better than 50 db
Input Level	: Micmore than 0.5 mV Line.....more than 60 mV
Output Level	: 0 VU (1.23 V RMS)
Equalization	: Correct equalization for playback of tapes recorded to the NAB curve.
Recording Bias Frequency	: 60 kc
Recording Level Indicator	: VU meter $\times 2$
Recording System	: CROSS-FIELD bias system, 4-track stereo/monaural system
Fast Forward and Rewind Time	: 90 seconds using 1,200 feet tape at 50 cycles. 75 seconds at 60 cycles.
Maximum Recording Time	: 8 hours monaural recording at 1-7/8 ips (1,200 feet recording tape). 4 hours stereo recording at 1-7/8 ips
Head	: Recording/playback head4-track stereo/monaural, low impedance 1,000 ohms at 1,000 cps Bias head 4-track stereo, low impedance 500 ohms at 60 kc. Erase head4-track stereo, low impedance 300 ohms at 60 kc.
Motor	: Hysteresis synchronous 2-speed motor
Transistor	: Silicon transistor $\times 11$ Diode $\times 2$ Rectifier $\times 2$
Power Supply	: AC 100 to 240 V, 50/60 cycles
Power Consumption	: 55 VA
Dimensions	: 13-1/2" H \times 13-1/2" W \times 9" D (340 H \times 340 W \times 230 D mm)
Weight	: 30.8 lbs (14.0 kg)

GENERAL INFORMATION

2. CONTROLS

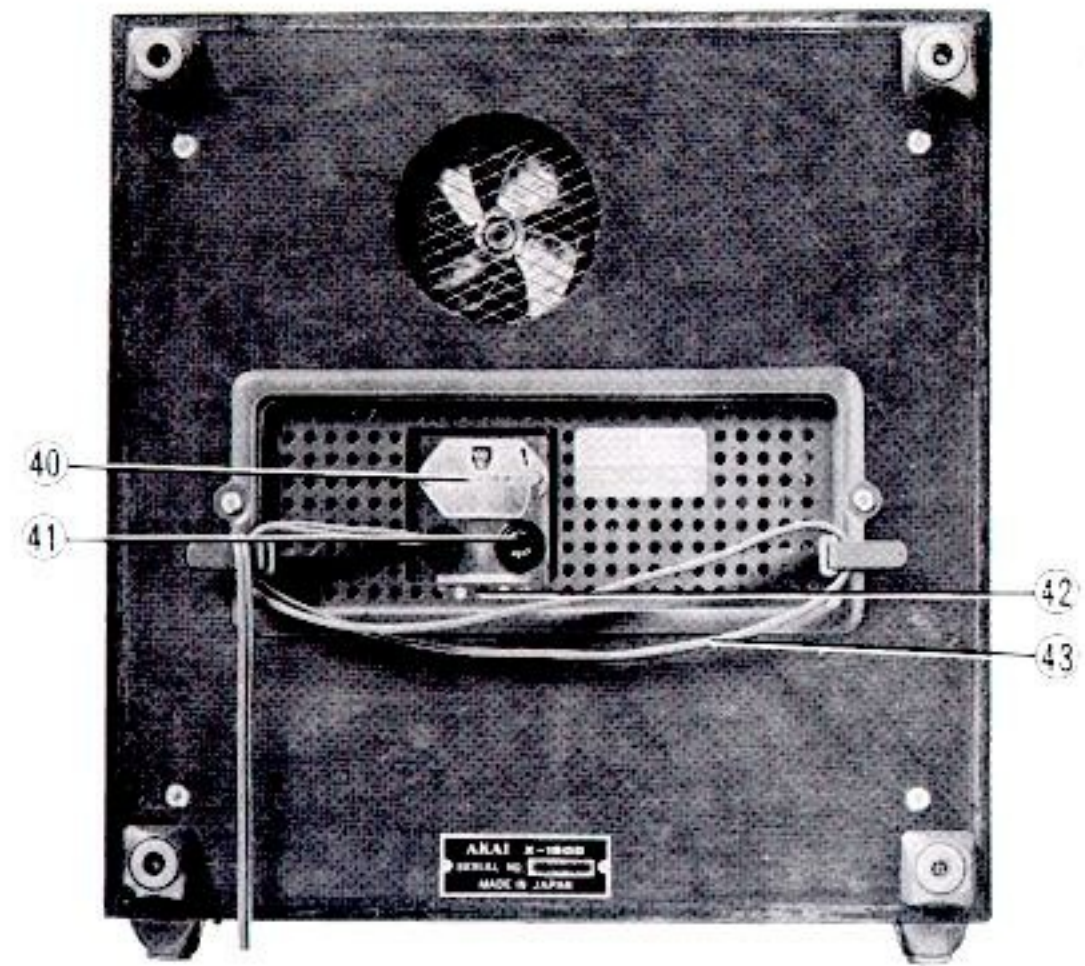
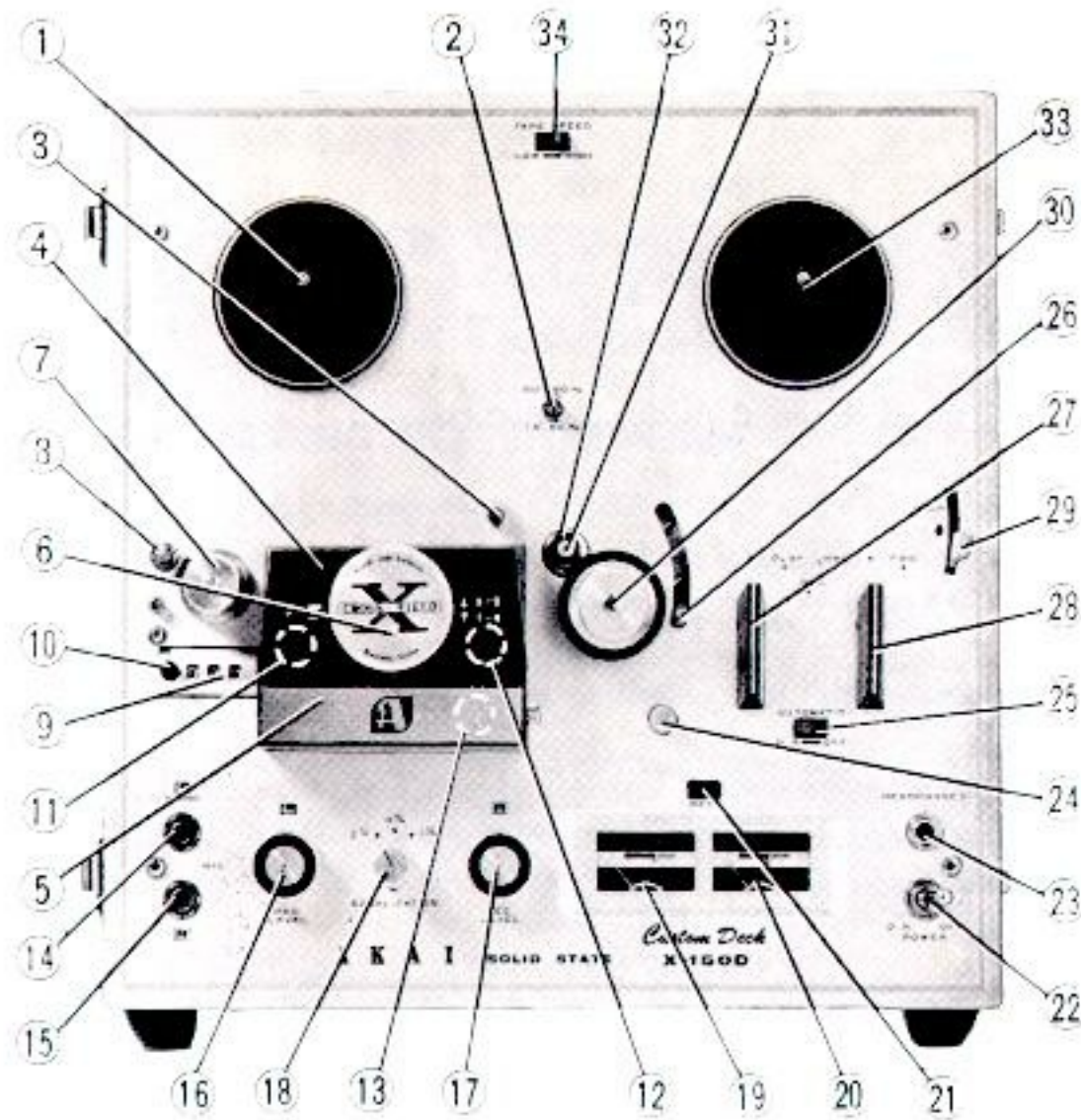

CONTROLS

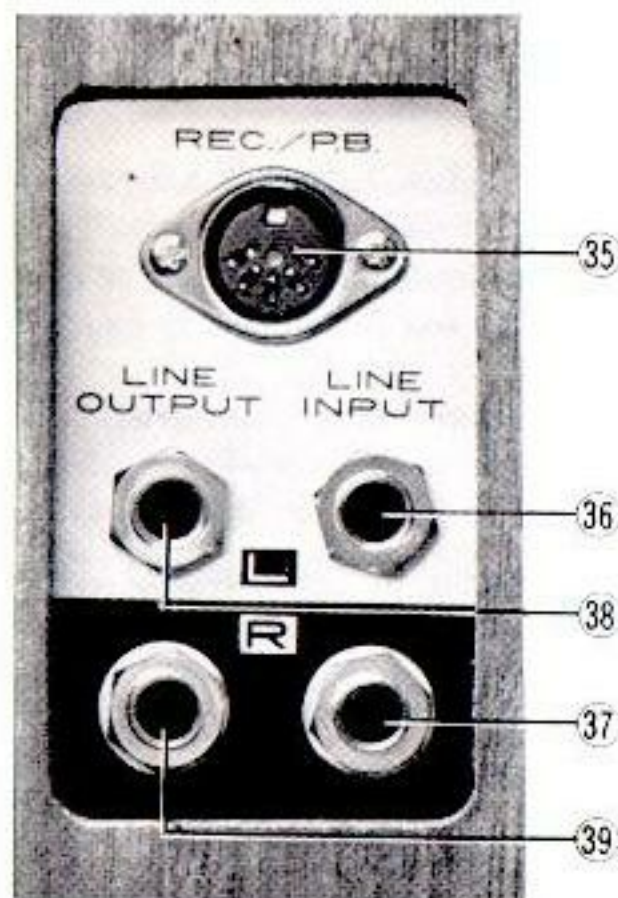

- ① Supply Reel Shaft
- ② Cycle Conversion Switch (A)
- ③ Capstan Storage Post
- ④ Head Cover (A)
- ⑤ Head Cover (B)
- ⑥ Track Selector Knob
- ⑦ Tape Guide
- ⑧ Tape Cleaner
- ⑨ Index Counter
- ⑩ Reset Button
- ⑪ Erase Head
- ⑫ Recording/Playback Head
- ⑬ Bias Head
- ⑭ Microphone Jack (Left)
- ⑮ Microphone Jack (Right)
- ⑯ Recording Level Control Knob (Left)
- ⑰ Recording Level Control Knob (Right)
- ⑱ Equalizer Knob
- ⑲ VU Meter (Left)
- ⑳ VU Meter (Right)
- ㉑ Recording Lamp

GENERAL INFORMATION

- ㉒ Power Switch
- ㉓ Stereo Headphone Jack
- ㉔ Recording Safety Button
- ㉕ Automatic Shut off (AS) Switch
- ㉖ Automatic Shut off (AS) Lever
- ㉗ Record/Playback Knob
- ㉘ Fast-Forward/Rewind Knob
- ㉙ Instant Stop Lever
- ㉚ Pinch Wheel
- ㉛ Capstan Shaft
- ㉜ Capstan
- ㉝ Take-Up Reel Shaft
- ㉞ Speed Change Switch
- ㉟ DIN Jack
- ㊱ Line Input Jack (Left)
- ㊲ Line Input Jack (Right)
- ㊳ Line Output Jack (Left)
- ㊴ Line Output Jack (Right)
- ㊵ Voltage Conversion Switch
- ㊶ Fuse Post
- ㊷ Cycle Conversion Switch (B)
- ㊸ AC Cord

The cross-field head created a sensation in the tape recorder market by making possible a wide range recording never before heard on any conventional tape recorder.

Using this cross-field head, Model X-150D provides a surprising recording performance of 30-23,000 cps at a tape speed of 7-1/2 ips, 30-18,000 cps at 3-3/4 ips and 30 to 9,000 cps at 1-7/8 ips.

What is superior about cross-field recording? How does it differ from typical recording methods as far as construction is concerned? On these, explanation is given below in sequences:

In the typical recording system, the signal current and the bias current are combined together and applied to the recording head. (Refer to Diagram 1.)

It is well known that the purpose of bias current is to record, at high sensitivity, a signal applied on the tape, with little distortion and minimizing noise generation.

However, the bias current providing such an advantage also has an undesirable character. That is, the wide magnetic field of the bias current affects the recorded signal, resulting in weakening or even erasing the signal. This phenomenon is particularly noticeable at high frequencies.

In the cross-field system, the signal current is applied to the recording head while the bias current is applied to the bias head. These two heads are located in different positions, as determined inter-relatively, so that the magnetic field of the bias will not affect the signal recorded on the tape, even when sufficient bias is applied. This allows the recorded signal to remain on the tape with high fidelity.

Diagram 1. Ordinary recording system

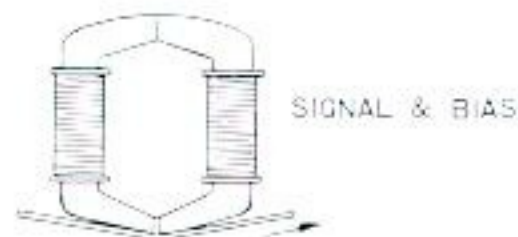
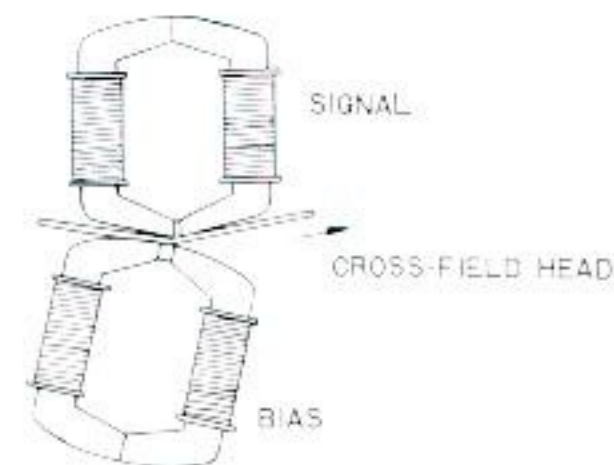
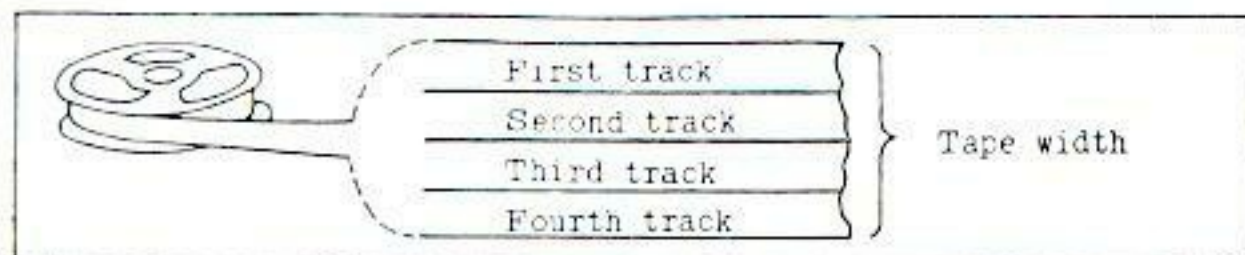

Diagram 2. Cross-field recording system



4. RECORDING/PLAYBACK FOR 4-TRACK

The Model X-150D employs the 4-track system, either stereo or monaural.



Track selection is made by the TRACK SELECTOR KNOB ⑥.

(A) Recording/Playback for 4-Track Stereo

For stereophonic recording two of these tracks are used at a time. Set the TRACK SELECTOR KNOB ⑥ in "STEREO" position. The first half of stereophonic recording/playback is made on Tracks No. 1 and 3 and the second half on Tracks No. 2 and 4 after the tape reels have been turned over.

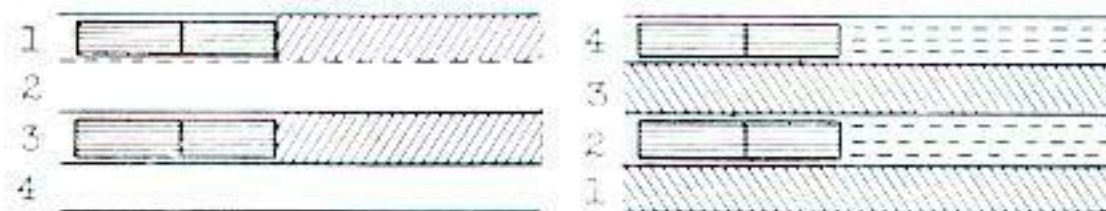

(B) Recording/Playback for 4-Track Monaural

Recording/Playback of monaural should be performed in the sequence of 1-4-3-2 (tracks).

① Monaural recording/playback on tracks No. 1-4

Set the TRACK SELECTOR KNOB ⑥ to "1-4" for recording on track No. 1 first, and then on track No. 4 after the tape reels have been turned over.

② Monaural recording/playback on tracks No. 3-2

Set the TRACK SELECTOR KNOB ⑥ to "3-2" for recording on track No. 3 first, and on track No. 2 after the tape reels have been turned over.

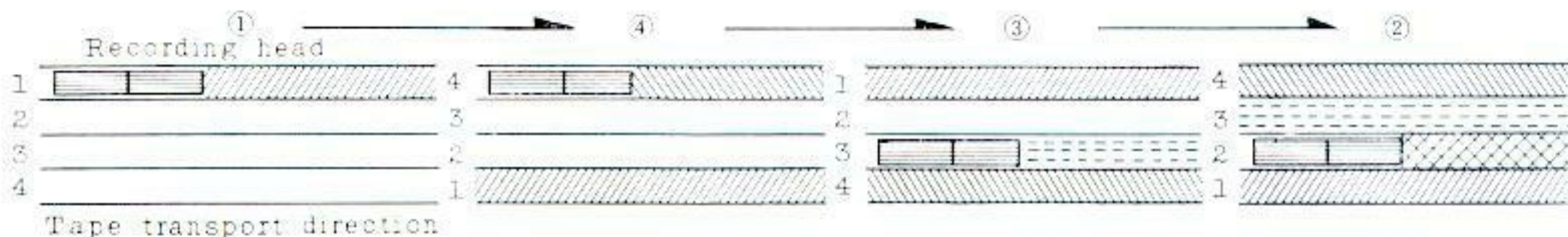

IMPORTANT: READ THE FOLLOWING INSTRUCTIONS CAREFULLY BEFORE OPERATING YOUR MACHINE:

- ① THE USE OF NEW TAPE WILL RESULT IN THE BEST RECORDINGS.
- ② THE SYMPTOMS LISTED BELOW DO NOT NECESSARILY INDICATE MECHANICAL FAILURE OF YOUR TAPE DECK. IF YOUR MACHINE EXHIBITS ANY OF THESE SYMPTOMS, CHECK FOR THE TROUBLE AS INDICATED.
 - (1) Loss of sensitivity and tone quality may be due to:
 - A. Dirty erase head. This will prevent prerecorded material from being completely erased.
 - B. Dust on the recording head. Clean the head gently with a soft cotton swab soaked in rubbing alcohol or carbon tetrachloride.
 - C. A.C. power voltage lower than the standard voltage to which your machine is adjusted.
 - (2) Irregularity in the tape transport may be due to:
 - A. Grime adhering to the heads.
 - B. Oil on the capstan.
 - C. Sticky or dirty tape surface.
 - D. Bent take-up reel.
 - (3) If your machine will not record, check the following for correct position:
 - A. Record/Playback knob.
 - B. Input plugs.

Note:

- (1) Before operating your machine, be sure to clean the surface of the head.
 - (2) Unused tape may become soft and sticky. It is advisable to run the tape once from the supply reel to the take-up reel before threading it for recording.
- ③ THE FOLLOWING NOTES ARE PROVIDED FOR YOUR CONVENIENCE.
- (A) If any trouble develops, please take your machine to the nearest authorized agent in your area or inquire at the Service Dept. of the Akai Company in Tokyo, Japan.
 - (B) Your Akai Tape Deck Model X-150D requires constant voltage for optimum performance.
 - (C) The standard 1,200 feet length of tape on a 7" reel plays up to 32 minutes at 7-1/2 ips in one direction.
 - (D) If the sound sources are so far away from the microphones that the volume control must be turned up to a maximum, some hum or noise will inevitably be recorded. In such instance, a test recording is recommended before attempting a final recording.

6. VOLTAGE AND CYCLE CONVERSION

POWER VOLTAGE ADJUSTMENT

The Model X-150D is operable anywhere in the world. With the built-in stepdown power transformer, the user can easily readjust the recorder to any one of the six stages of power voltage from 100 to 240 volts A.C. Generally, the recorder's input voltage is preset for the forwarding territory. The user is requested to check the previously set voltage before operation. This can be seen at the rear of the recorder. If another voltage is required, readjusting of the voltage can be made in accordance with the following instructions.

- (1) Take off the cover panel by removing two mounting screws as shown in Fig. A. Then, pull out the VOLTAGE CONVERSION SWITCH (A) gently and reset the knob so that the desired voltage will appear on the panel. (See Fig. B)
- (2) The voltage conversion switch is a plug-in type movable in six steps, 100/110/120/200/220/240. For example, if the power voltage distributed in your area is 220 volts A.C., reset the switch to 220 mark.
- (3) Change fuse according to voltage.
Fuse: 100V~120V 0.8A, 200V~240V 0.4A

CAUTION: Disconnect the power plug from the AC outlet before readjusting power voltage. To maintain optimum performance and to prolong the life of your machine, it is important that the line voltage be held within 10 percent deviations from the standard voltage.

POWER CYCLE CHANGE

Correct tape speed is not obtainable if the CYCLE CONVERSION SWITCHES are not properly adjusted. The CYCLE CONVERSION SWITCH (A) (2) is located at the center of the deck top panel and the CYCLE CONVERSION SWITCH (B) (4) at the rear of the recorder. Using a screw driver, rotate the CYCLE CONVERSION SWITCH (A) (2) counter clockwise approximately one-eighth of a turn. The switch can then be moved either OUT or IN. 50 cycle operation is obtained by moving the switch OUT (Fig. C), and 60 cycle operation, by the switch IN (Fig. D). The switch (2) should be rotated back to its original position after it has been moved either OUT or IN. The CYCLE CONVERSION SWITCH (B) (4) should also be reset.

CAUTION: Do not attempt to rotate the CYCLE CONVERSION SWITCHES when the motor is not running.



GENERAL INFORMATION

7. SELECTION OF TAPE SPEEDS

TAPE SPEED INCHES PER SECOND	POSITION OF SPEED CHANGE SWITCH		CAPSTAN BUSHING		U S E
	LOW	HIGH	YES	NO	
1-7/8	○			○	Long time recording of Jazz, Speech, Lecture, etc.
3-3/4	○		○		High fidelity recording of Popular or Classical music, etc.
7-1/2		○	○		Recording music with max. clarity, Playback of pre-recorded tape.

The X-150D operates usually on 3 tape speeds, 7-1/2, 3-3/4 and 1-7/8 ips. Refer to the chart above for selecting an adequate tape speed. Tape speed is determined by the motor speed and by the capstan bushing on the tape drive capstan shaft.

1-7/8 ips. This tape speed is obtained by setting the SPEED CHANGE SWITCH ④ to "LOW". The capstan bushing is not used but is left on the storage post.

3-3/4 ips. This tape speed is obtained by setting the SPEED CHANGE SWITCH ④ also in "LOW" position. The capstan bushing is mounted on the capstan shaft and is locked automatically in position by the notches.

7-1/2 ips. This tape speed is obtained by setting the SPEED CHANGE SWITCH ④ in "HIGH" position. The capstan bushing is used. 15 ips tape speed is also available by using an extra capstan and a pinch wheel which are optional.

RECORDING TIME

4-TRACK STEREO			
TAPE LENGTH	TAPE SPEED		
	1-7/8	3-3/4	7-1/2
1200ft	4hrs	2	1
1800	6	3	1.5
2400	8	4	2
4-TRACK MONO			
1200	8	4	2
1800	12	6	3
2400	16	8	4

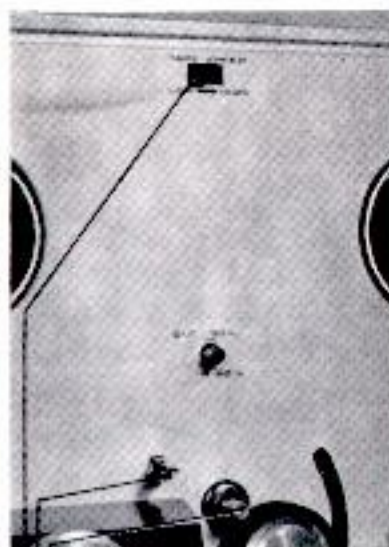

—CAPSTAN BUSHING
—CAPSTAN STORAGE POST
—SPEED CHANGE SWITCH

1. THREADING THE TAPE

Place your recording tape on the SUPPLY REEL SHAFT ① and the empty reel on the TAKE-UP REEL SHAFT ②.

Thread the tape as illustrated by the dotted line:

To keep the reels from falling down, lock the reels with the retainers provided on the top of REEL SHAFTS.

IMPORTANT:

If the automatic shut-off is required, thread the tape through the AS LEVER ④. If not, pass the tape directly onto the take-up reel. In this case, set the AS SWITCH ⑤ to "OFF".

2. STEREO PLAYBACK

Connect the recorder to AC power source using the attached AC CORD.

- (A) Set the POWER SWITCH ⑥ to "ON".
- (B) Set the TRACK SELECTOR KNOB ⑦ to "STEREO".
- (C) Select the tape speed.
- (D) Set the EQUALIZER KNOB ⑧ to 7-1/2, 3-3/4 or 1-7/8, whichever is consistent with tape speed.

Now, put your pre-recorded tape on the recorder.

The Model X-150D does not include power amplifier nor loud-speakers. It, therefore, is necessary to provide an external stereo amplifier and speakers for stereophonic playback.

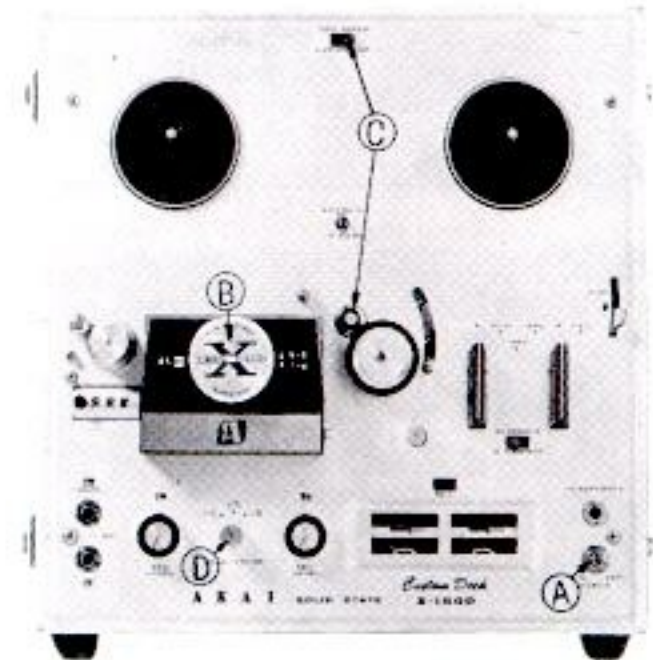
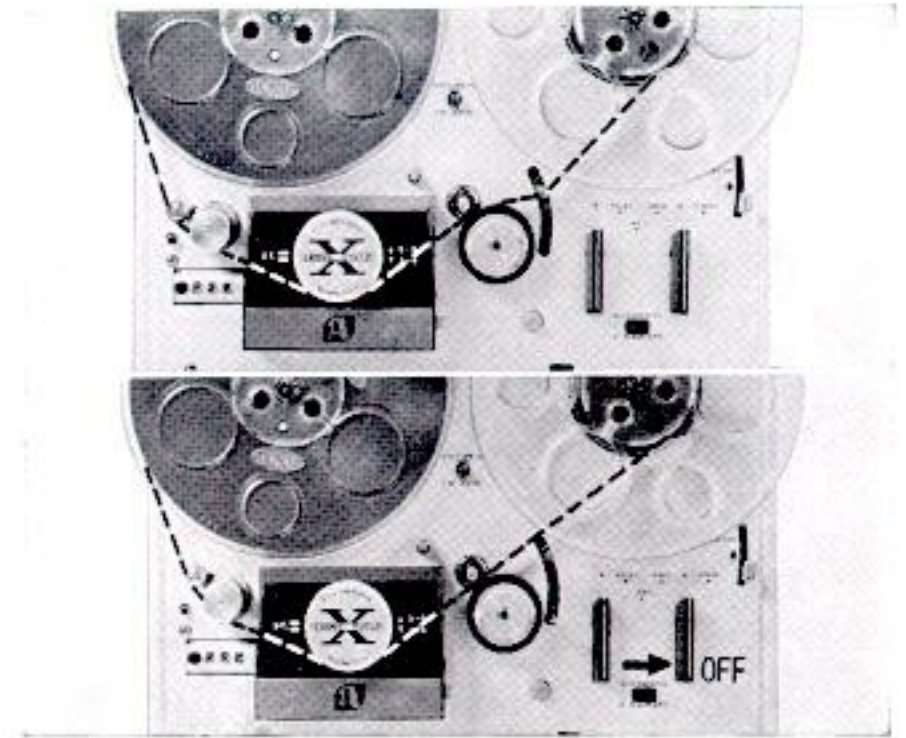

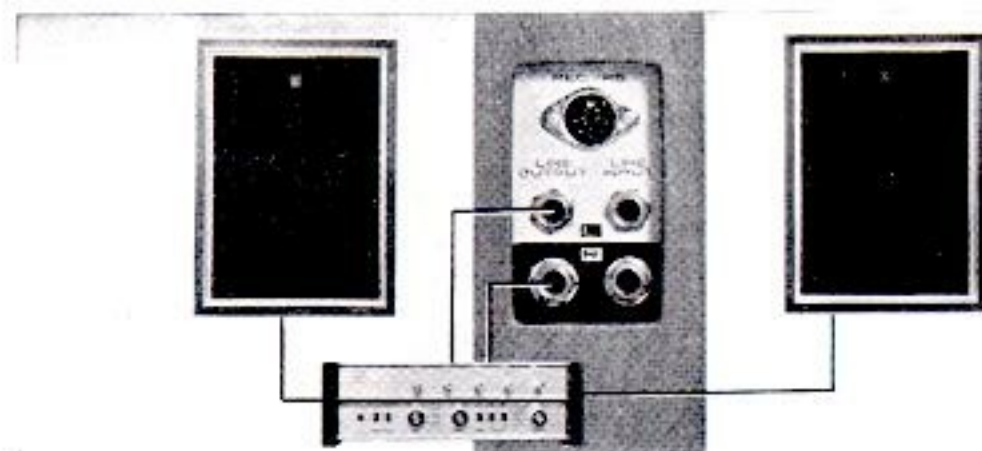

STEREO PLAYBACK

- (E) Connect both LINE OUTPUT JACKS (18) and (19) to TAPE INPUT JACKS or AUX INPUT JACKS of the external amplifier. Connect two loud speakers to the power amplifier accordingly.

IMPORTANT:

- The output level at the X-150D's output jack is maximum at 1.23 volts. Check your amplifier before operation with input terminals.
- (F) Set the RECORD PLAYBACK KNOB (27) to "PLAY".
- (G) Adjust the volume of sound by the volume control knobs of the external amplifier.

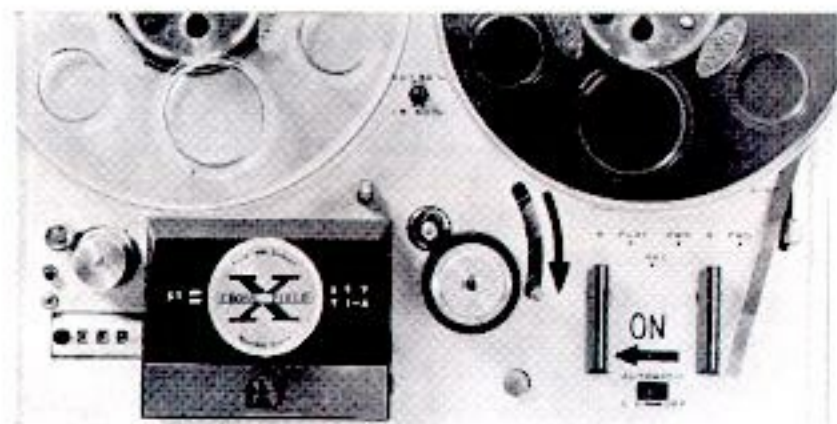

3. AUTOMATIC SHUT-OFF

One of the exclusive features of the X-150D is the automatic shut-off function of the unit. Whenever the tape comes to the end, or is damaged by accident, the AS LEVER (28) drops down so that the functions of both deck and amplifier are automatically cut off. If automatic shut-off operation is desired, set the AS SWITCH (25) in "ON" position.

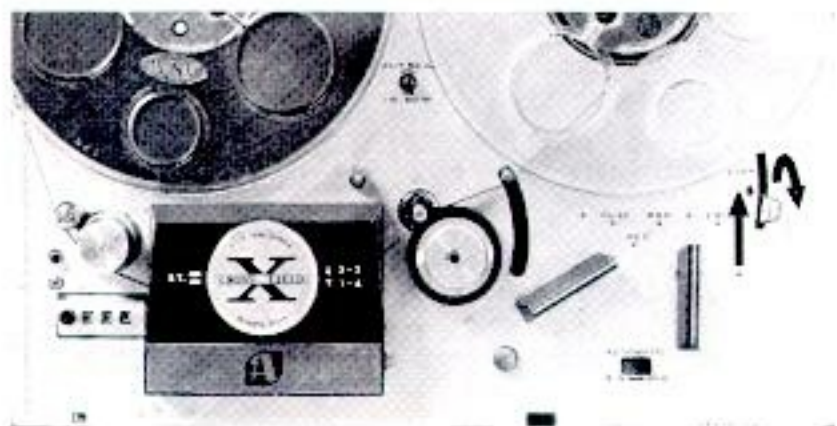

4. INSTANT STOP CONTROL

To stop the tape momentarily on recording or playback, push the INSTANT STOP LEVER (29) as shown in the Figure. The lever will be locked in the stop position, and it can be released by lifting the curved tip upward. The INSTANT STOP LEVER (29) will not function when the recorder is in either fast forward or rewind operation.

An optimum recording level can be determined before starting the recording by using the INSTANT STOP LEVER (29) after the recorder is set in a normal recording mode of operation. Adjust the volume control while watching the VU METERS (19) and (20).

5. STEREO RECORDING

- Ⓐ Set the POWER SWITCH ②② to "ON".
- Ⓑ Set the TRACK SELECTOR KNOB ⑥ to "STEREO".
- Ⓒ Select the tape speed as desired.
- Ⓓ Set the EQUALIZER KNOB ⑮ to 7-1/2, 3-3/4 or 1-7/8, whichever is consistent with tape speed.
- Ⓔ Push the RESET BUTTON ⑩ and set the INDEX COUNTER ⑨ to "000". This counter provides reference numbers for locating specific points of the recordings on the tape.

Place the recording tape on the recorder.

Insert the MICROPHONE PLUGS into the MICROPHONE INPUT JACKS ⑭ and ⑮.

Keep the two microphones at least 7 feet apart. Thread the tape in the usual manner and push the INSTANT STOP LEVER ⑳ upward until it locks. Then, turn the RECORD/PLAYBACK KNOB ㉑ into "REC." position while depressing the RECORDING SAFETY BUTTON ㉒.

Microphone volume level may be adjusted and balanced by the RECORDING LEVEL CONTROL KNOBS ⑰ and ⑱. Normal recording should not exceed the black zone on VU METERS ⑲ and ㉓.

After an optimum recording level is determined, release the INSTANT STOP LEVER ㉑ to start stereo recording.

OPERATING INSTRUCTIONS

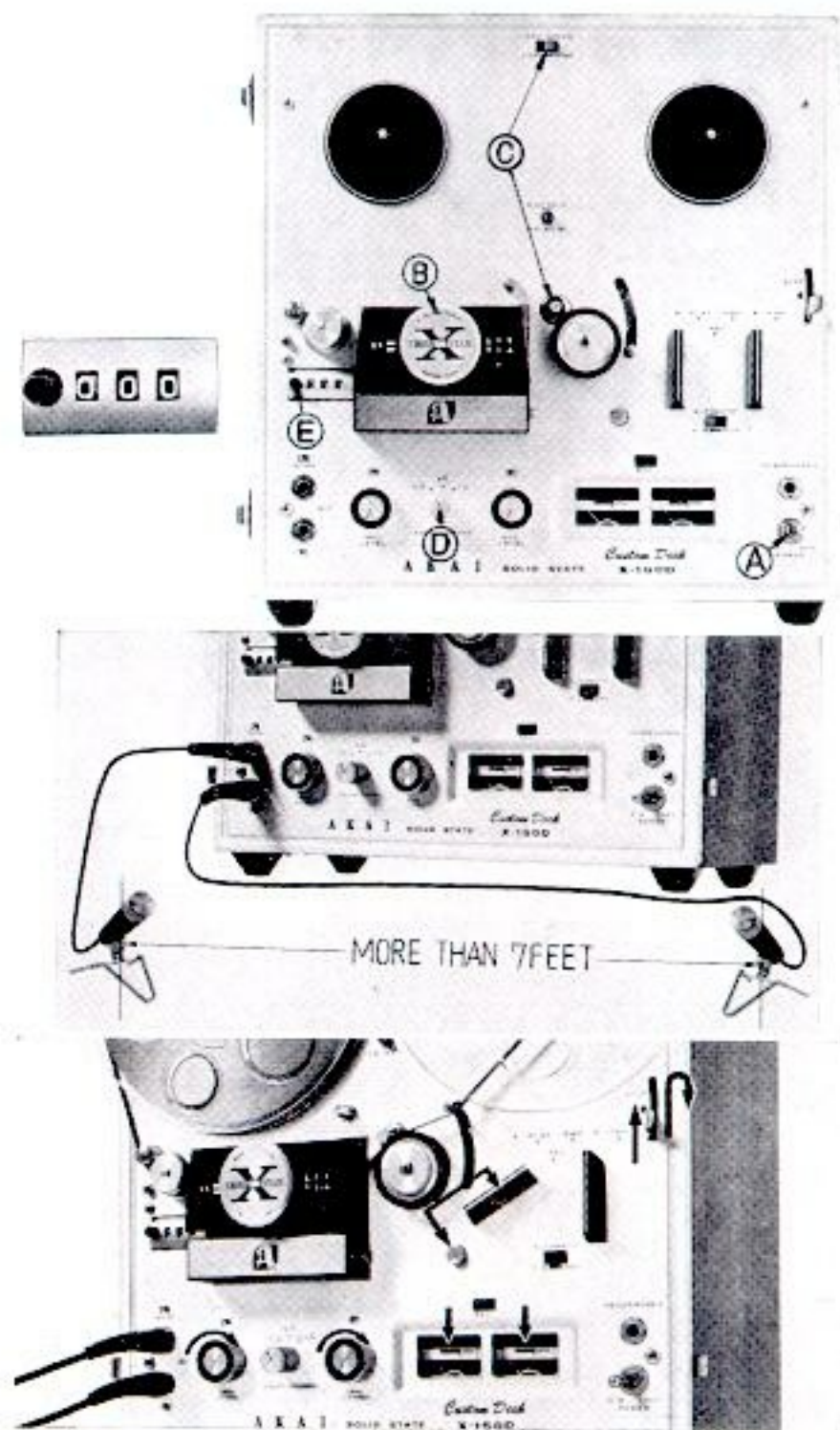

OPERATING INSTRUCTIONS

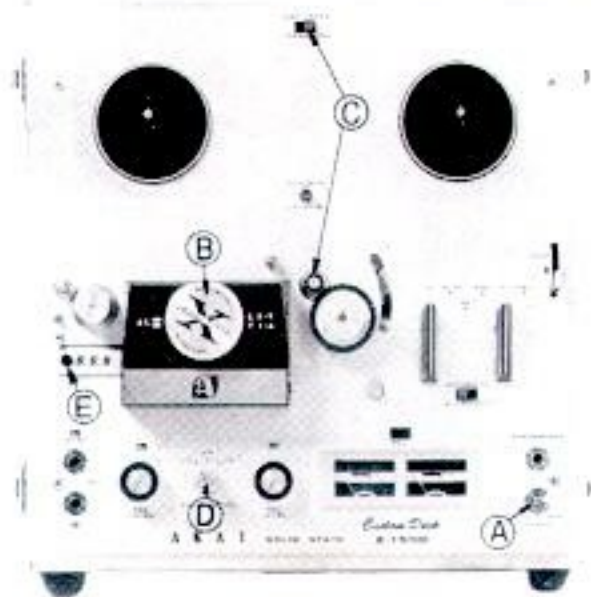

6. RECORDING FROM STEREO BROADCAST

Stereophonic broadcast programs may be recorded from two sets of radio receivers. This is accomplished by connecting LINE INPUT JACK (LEFT) ②⑥ of Model X-150D to the voice coil terminals of the left-hand speaker and LINE INPUT JACK (RIGHT) ②⑦ to similar terminals of the right-hand speaker of the respective radio set. Recording level is adjusted by RECORDING LEVEL CONTROL KNOBS ①⑥ and ①⑦.

7. RECORDING FROM STEREO DISCS

To record from a stereo disc, a crystal pick up or ceramic pick up can be connected directly to the LINE INPUT JACKS ②⑥ and ②⑦. Magnetic cartridge output should be connected to a separate preamplifier and then to the LINE INPUT JACKS ②⑥ and ②⑦.

8. MONAURAL RECORDING ON TRACKS NO. 1-4

- Ⓐ Set the POWER SWITCH ②② to "ON".
- Ⓑ Set the TRACK SELECTOR KNOB ②③ to "1-4".
- Ⓒ Select the tape speed as desired.
- Ⓓ Set the EQUALIZER KNOB ②④ to 7-1/2, 3-3/4 or 1-7/8, whichever is consistent with tape speed.
- Ⓔ Push the RESET BUTTON ②⑤ and set the INDEX COUNTER ②① to "000".

MONAURAL RECORDING ON TRACKS NO. 1-4

In monaural recording, only the left channel amplifier is used. The right channel amplifier is not required for this operation.

The microphone plug should be inserted into the MICROPHONE INPUT JACK (LEFT) ⑭.

Place the recording tape on the recorder.

Push the INSTANT STOP LEVER ⑲ upward until it locks, and then turn the RECORD/PLAYBACK KNOB ⑳ into "REC" position while depressing the RECORDING SAFETY BUTTON ㉑. Adjust the RECORDING LEVEL CONTROL KNOB (LEFT) ⑯ to normal recording level, while watching the VU meter indicator of the left channel amplifier. VU meter reading should not exceed the black zone.

After a correct recording level is determined, release the INSTANT STOP LEVER ⑲ to start recording on track No. 1.

At the end of recording on track No. 1, reverse both tape reels for the next recording on track No. 4.

9. MONAURAL RECORDING ON TRACKS NO. 3-2

Set the TRACK SELECTOR KNOB ⑥ to "3-2". For the rest of operation, just follow the instructions given for recording tracks No. 1-4. Recording is made first on track No. 3, then on track No. 2 with both reels reversed.

To record from a disc player or an external amplifier monaurally, use the LINE INPUT JACK (LEFT) ㉒. A crystal pick up can be connected direct to the LINE INPUT JACK (LEFT) ㉒. When recording from an external amplifier, connect to the LINE INPUT JACK (LEFT) ㉒ from the TAPE OUTPUT of external amplifier.

To record from a radio, connect radio cable to the radio speaker or to the earphone jack. The cable plug should be inserted into LINE INPUT JACK (LEFT) ㉒.

OPERATING INSTRUCTIONS

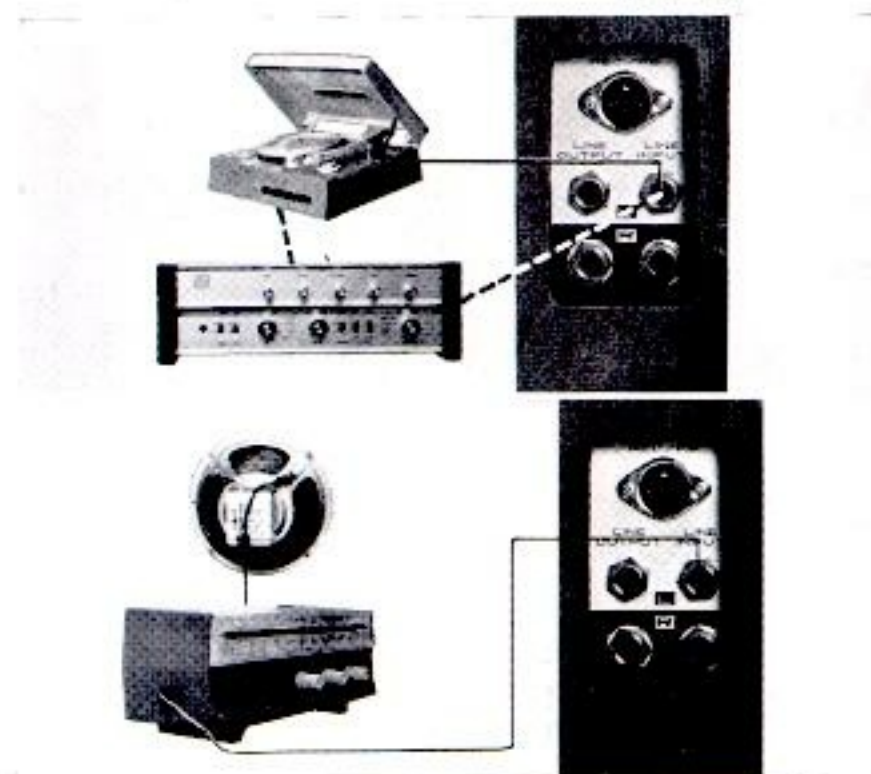
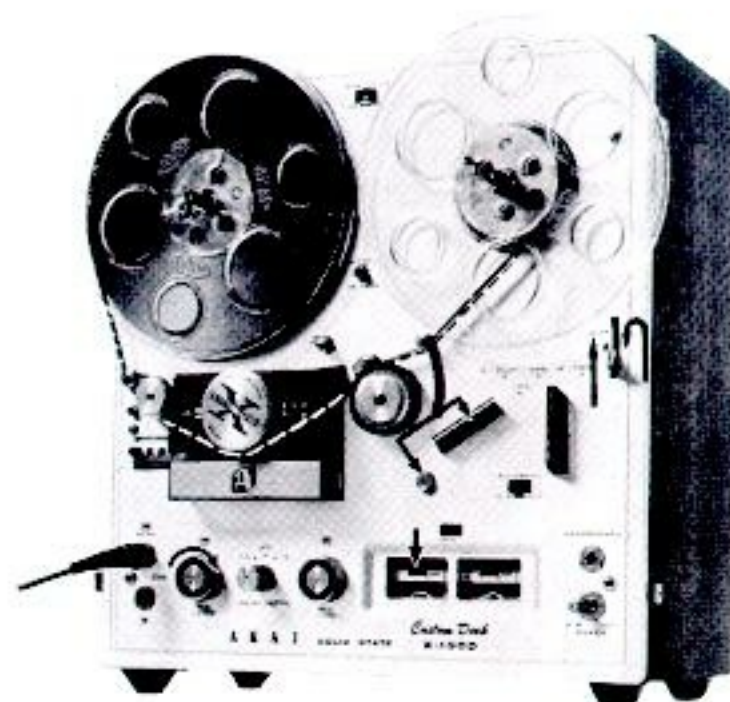

OPERATING INSTRUCTIONS

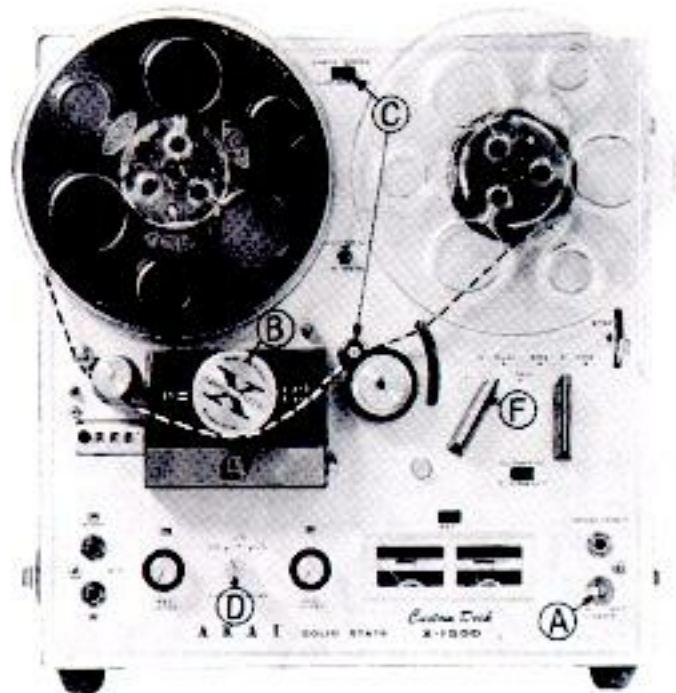

10. MONAURAL PLAYBACK

- (A) Set the POWER SWITCH (22) to "ON".
- (B) Set the TRACK SELECTOR KNOB (6) to "1-4".
- (C) Select the tape speed as desired.
- (D) Set the EQUALIZER KNOB (18) to 7-1/2, 3-3/4 or 1-7/8, whichever is consistent with tape speed.

Place the pre-recorded tape on the tape deck.

On monaural playback, only the left channel amplifier should be used.

- (E) Connect LINE OUTPUT JACK (LEFT) (18) to TAPE INPUT or AUX INPUT JACK of an external amplifier. Also connect the loud speaker to the power amplifier.
- (F) Set the RECORD/PLAYBACK KNOB (27) to "PLAY".

After completing monaural playback on track No. 1 and No. 4, set the TRACK SELECTOR KNOB (6) to "3-2" for continuing with track No. 3, then track No. 2.

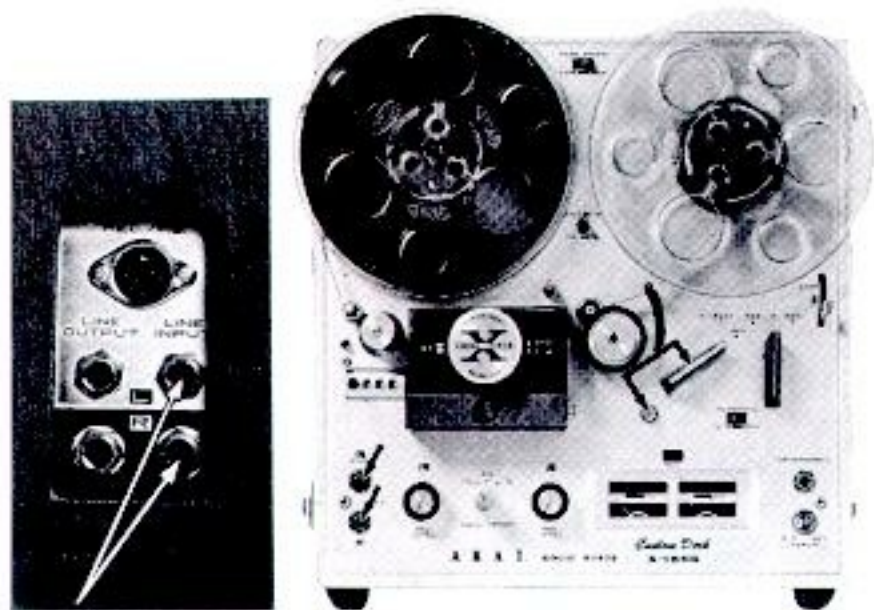
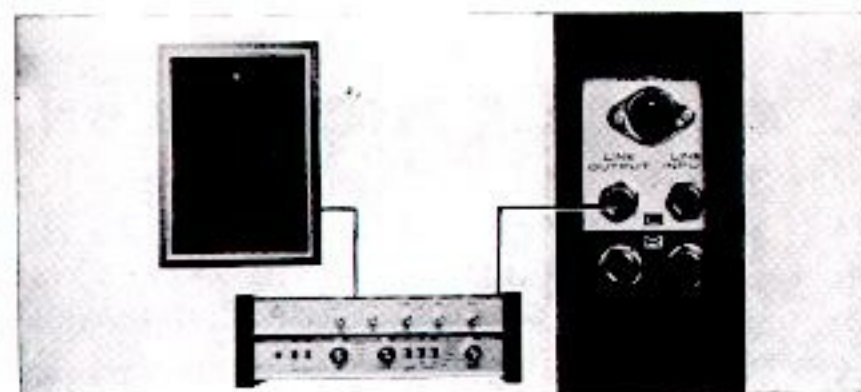

11. TAPE ERASING

Any signal information previously recorded on a tape will be erased automatically as a new recording is made on the same tape. Thread the tape, and place in normal record position. There should be no plugs connected to recorder's input jacks. RECORDING LEVEL CONTROL KNOBS (16 and 17) should be held in "0" position. A BULK TAPE ERASER is recommended for quick and complete erasure.

12. FAST FORWARD AND REWIND

Fast forward or rewind is accomplished by turning the FAST FORWARD/REWIND KNOB 28 into the proper position. Put the tape in fast forward or rewind for rapid selection of the recordings on the tape. The FAST FORWARD/REWIND KNOB 28 cannot be turned out of the stop position unless the RECORD/PLAYBACK KNOB 27 is in stop position, and vice-versa.

13. MONITORING

Monitoring is made by connecting the stereo headphone to the STEREO HEADPHONE JACK 23.

On monaural as well as stereo recording, please use of the stereo headphone. Caution: The stereo headphone should be of low impedance type (8 ohms).

14. TAPE SPLICING AND EDITING

Superimpose the tapes and cut them diagonally as illustrated. (This diagonal cutting eliminates the "click" or "pop" sound of the splice.)

Register the cut ends and apply a splicing tape on the glossy side of the record tape.

Press the splice tape with fingers firmly to secure the ends evenly. Trim off excess splicing tape. Preferably, cut the recording tape slightly along its edge as illustrated by the dotted line. This eliminates the possibility of a sticky splice. Tape splicing using scissors requires skillful work. The scissors should not be magnetized. But, our specially designed portable splicer can do the job with ease.

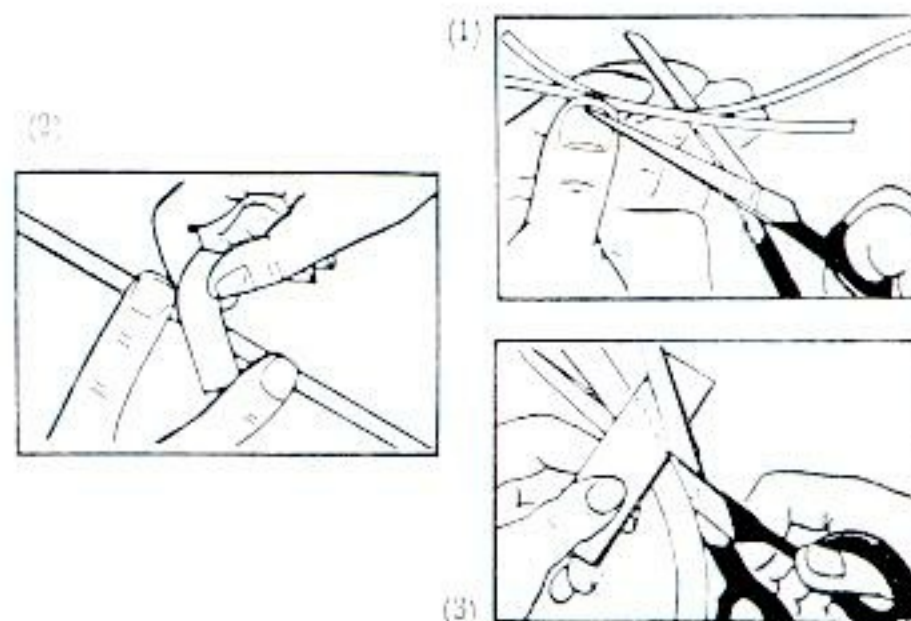
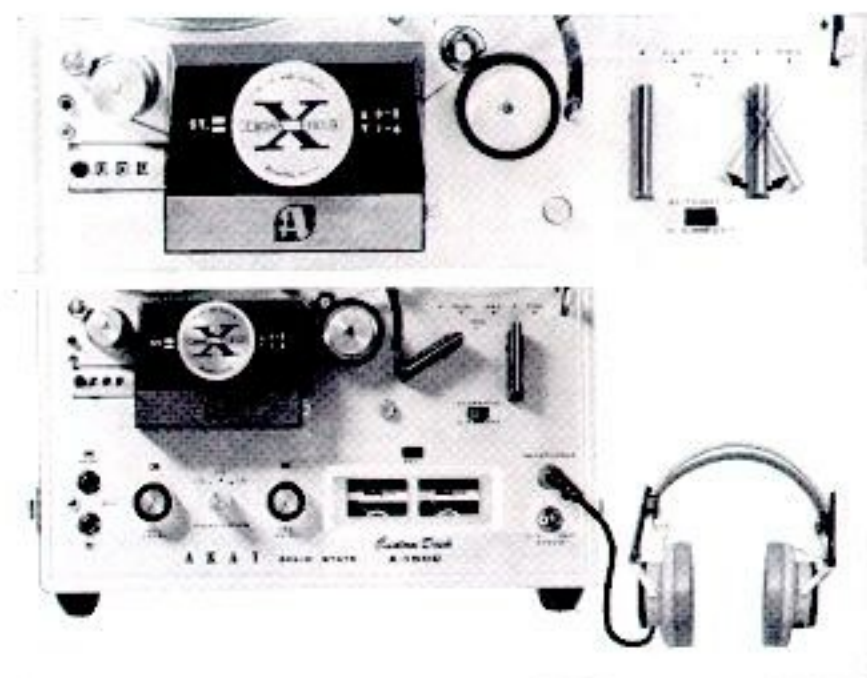

TAPE OXIDE DEPOSITS ARE 90% OF CAUSES OF THE YOUR TAPE RECORDING FAILURES.

It is imperative for quality performance of a tape recorder to keep the heads neat and clean at all times.

Dust and magnetic particles from the tape tend to deposit on the heads after prolonged use of the tape recorder. This would result in poor head-to-tape contact, deteriorating sound quality and sensitivity.

Such dust would cause a significant drop in recording, playback and erase quality levels.

EXAMPLE



CLEAN HEAD

Frequency response curve

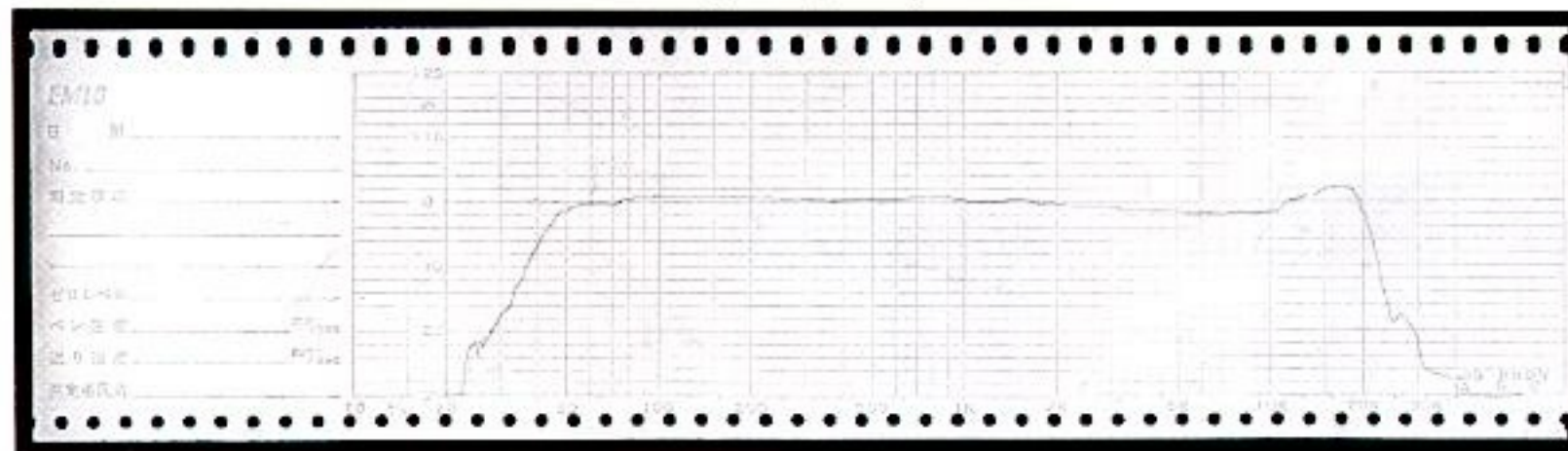

DUSTY HEAD



Make it a rule to clean the heads every time you use your tape recorder. AKAI's Head Cleaning Kit (Accessory No. HC-500) is recommended for removing foreign matter deposited on the heads. If this kit is not available, use alcohol.



16. HEAD DEMAGNETIZATION



Normally, the steel pole pieces which form a part of the recording and playback heads become slightly magnetized. The effect of the slight head magnetization is to partially erase the tape. Mostly high frequencies suffer. Generally, slightly magnetized heads can be detected by noticing loss of normal high frequency response which cannot be corrected through head alignment. Severe magnetization which may result if magnetized tools are used in the vicinity of the heads will result in noise or considerable distortion in addition to the loss of high frequency response. Although the X-150D already has a built-in Head Demagnetizing circuit, it is recommended that head demagnetization be performed periodically.

After removing the head cover, head demagnetization can be accomplished by touching the head lightly with the demagnetizer and making several small circular motions over all head surface areas as well as the head housing.

17. TAPE DUPLICATION

Connecting AKAI X-355 Tape Recorder with X-150D.

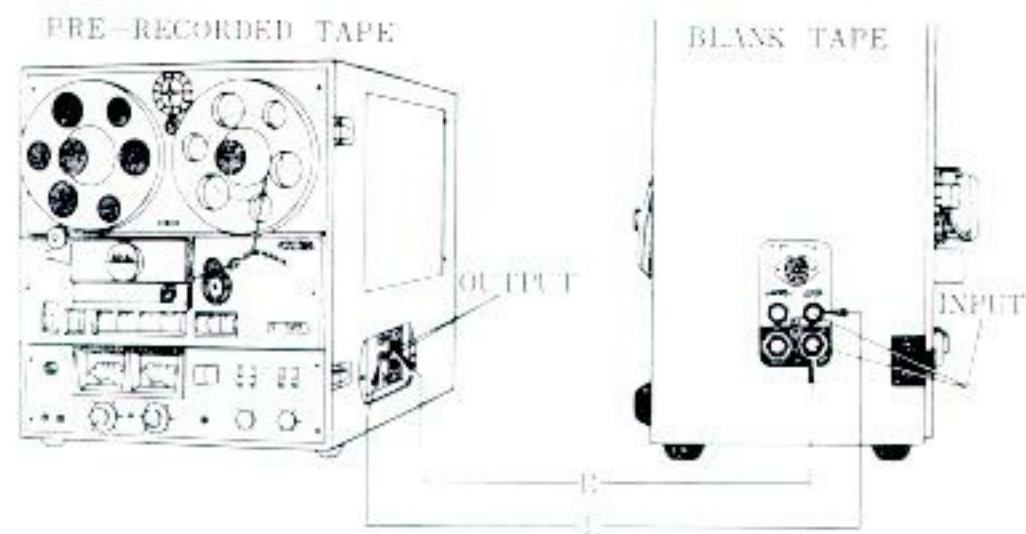

Connecting AKAI M-Series Tape Recorder with X-150D.

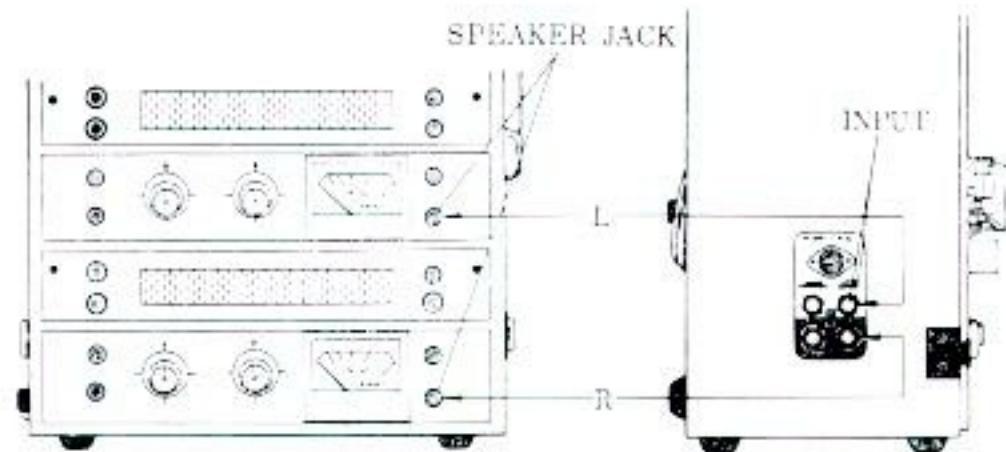

18. DIN (ONE MULTIPLE-CONNECTION) JACK

OPERATING INSTRUCTIONS

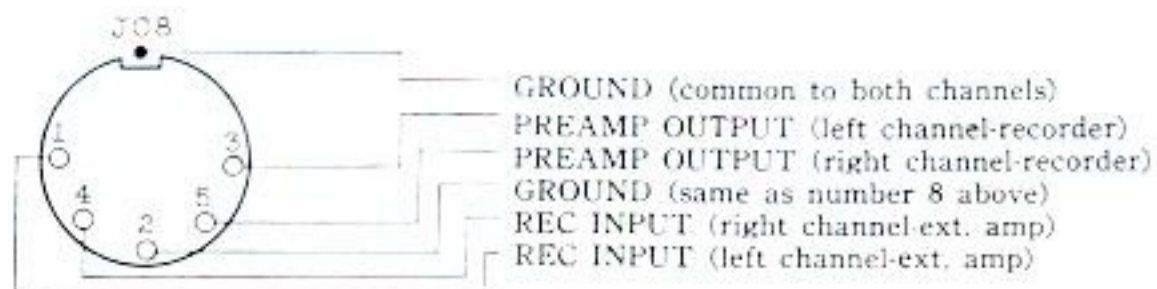

← Front View of DIN Jack

The DIN JACK is provided on the right side of the X-150D for interconnecting the X-150D with an external stereo amplifier that has the same connection jack. This system will permit easy recording and playback of stereophonic programs through an external stereo amplifier as the complexity of connecting or disconnecting more than 4 separate plugs from the recorder's panel side is not needed.

If your amplifier is not equipped with the DIN jack and the use of this one connection system is required, consult a radio engineer for the necessary modification of your amplifier.

19. VENTILATION

The Model X-150D has a unique ventilation system. It is so designed that air circulation inside of the unit is properly maintained at all times and no excessive heat which would shorten the life of the component parts is developed. Although the X-150D is tropicalized in construction, it is recommended that the unit always be spaced a short distance apart from a wall, screen, or any other obstacle which might prevent good air circulation around the unit.

1. ACCESSORIES OPTIONAL



CM-15

Condenser Microphones No. CM-15

Akai's very latest high fidelity microphone is designed for the professional and Hi-Fi enthusiast. This unit consists of a microphone and pre-amplifier, and permits simultaneous use of two microphones for stereo purposes.

Frequency response: 50 to 15,000



DM-13

Dynamic Microphones No. DM-13

Although compact, extremely high quality dynamic microphones. They are guaranteed to give complete satisfaction to the most critical audio enthusiast and professional users.

Frequency response: 50 to 12,000



AS-3

Tape Splicer No. AS-3

This tape splicer is a small pocketable device and not only provides easy splicing but also preserves the original quality of recording.



AH-6

Head Demagnetizer No. AH-6

Normally the steel pole pieces which form a part of the tape heads become slightly magnetized. The effect of the slight magnetization is to partially erase the tape (with high frequencies suffering most). A periodical application of the Head Demagnetizer is the best way to keep the original quality of the tape. The AH-6 has a built-in on-off switch and a neon bulb.

ACCESORIES OPTIONAL

ACCESSORIES

Telephone Pick-up No. AP-2

This is designed to record telephone conversations with maximum clarity and sensitivity. Just press it on to the back of the telephone receiver. Rubber suction cup holds the pick-up in position.



AP-2

Tape Eraser No. ATE-7

This unit erases any previously recorded materials completely in a few seconds and accomodates tape reels from 3" to 7" in diameter. It is designed to provide maximum erasing efficiency. Has a pop-up shaft to hold the tape reel in position and also serves as a power switch and on-off bulb indicator of the unit.



ATE-7

Stereo Headphone No. ASE-9S

In order to enjoy true stereophonic effects with the Akai tape recorder, the Stereo Headphones ASE-9S is recommended.



ASE-9S

Head Cleaning Kit No. HC-500

HEAD CLEANER proves its value when used to wipe off the brownish-red oxide powders that accumulate on both the head assembly and pinch wheel. Since these powders affect high frequency response, only good head cleaner should be used.



HC-500

ACCESSORIES

ACCESSORIES OPTIONAL



TC-300



MAGNETIC TAPE



TAPE REEL

Tape Cleaning Kit No. TC-300

This Kit has been designed for the discriminating home enthusiast who wants to insure the longevity, and frequency response of his tapes. It enables you to clean off dust and other foreign particles that accumulate on tape, thus eliminating the main cause of tape squeaking.

AKAI Magnetic Tape & Tape Reel

AKAI Magnetic Tape

- AT-5S (600 feet)
- AT-7S (1,200 feet)
- AT-10S (2,400 feet)
- AT-5L (900 feet)
- AT-7L (1,800 feet)
- AT-10L (3,600 feet)

AKAI Tape Reel

- ATR-5 (for 5")
- ATR-7 (for 7")

2. ACCESSORIES STANDARD

DIN Plug: Four Separate RCA Plugs Cord	1
Spare Fuse	2

Silicone Oil	1
Felt Pads	2
Operator's Manual	1

10010280776